

TM 9-4910-783-13&P

TECHNICAL MANUAL

OPERATOR'S, UNIT, AND DIRECT SUPPORT MAINTENANCE MANUAL
(INCLUDING REPAIR PARTS AND SPECIAL TOOLS LIST)

FOR

STANDARD AUTOMOTIVE TOOL SET (SATS)
(National Stock Number (NSN) 4910-01-490-6453),

FIELD MAINTENANCE MODULES (FMM)

FMM1 (NSN 4910-01-501-7342) &

FMM2 (NSN 4910-01-501-7343)



DISTRIBUTION STATEMENT A - Approved for public release; distribution is unlimited.

COPYRIGHT RELEASE – Kipper Tools, 2375 Murphy Blvd., Gainesville, Georgia 30504, has given the Government permission to copy and distribute to Government agencies TM 9-4910-783-13&P.

HEADQUARTERS, DEPARTMENT OF THE ARMY

SEPTEMBER 2005

TM 9-4910-783-13&P

WARNING SUMMARY

This warning summary contains general safety warnings and hazardous material warnings that must be understood and applied during operation and maintenance of this equipment. Failure to observe these precautions could result in serious injury or death to personnel. Also included are explanations of safety and hazardous materials icons used within the technical manual.

EXPLANATION OF SAFETY WARNING ICONS



ELECTRICAL – electrical wire to arm with electricity symbol running through human body shows that shock hazard is present.



HEAVY OBJECT – human figure stooping over heavy object shows physical injury potential from improper lifting technique.

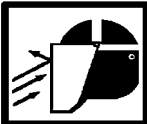

FLYING PARTICLES – arrows bouncing off face with face shield shows that particles flying through the air will harm face.



EYE PROTECTION – person with goggles shows that the material will injure the eyes.



CRYOGENIC – hand in block of ice shows that the material is extremely cold and can injure human skin or tissue.



FIRE – flame shows that a material may ignite and cause burns.



VAPOR – human figure in a cloud shows that material vapors present a danger to life or health.



CHEMICAL – drops of liquid on hand shows that the material will cause burns or irritation to human skin or tissue.

TM 9-4910-783-13&P

GENERAL SAFETY WARNING DESCRIPTION

WARNING



HIGH VOLTAGE exists in the electrical system of this equipment; DEATH ON CONTACT may result if personnel fail to observe safety precautions.

Confirm that container electrical system is properly grounded before connecting the primary power supply or starting the generator. Failure to properly ground the container may result in death, severe bodily injury or damage to equipment.

Do not attempt connection of live line to Power Input Receptacle. Deactivate power source or generator before procedure.

WARNING



Heavy object requires four-person lift.

Heavy object requires eight-person lift.

WARNING

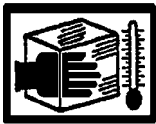

In extreme cold, do not touch metal parts with bare hands. Severe skin damage may result.

WARNING

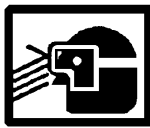
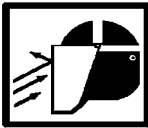

Use of compressed air during cleaning can cause debris to hurt the eye and skin. Use only with approved personal protective equipment.

WARNING



Utilize single-barrier hearing protection when operating the generator.

WARNING

Never transport SATS with door open. Transporting containers with doors open may cause serious injury or death to personnel.

WARNING

Failure to ensure that the forklift is capable of handling the full weight of the container and contents may result in damage to container. Improper lifting could result in the container unit sliding off tines causing personal injury or death.

TM 9-4910-783-13&P

WARNING

Failure to ensure forklift tines entrance into tubes may result in damage to the container unit. Improper lifting could result in the container unit sliding off tines causing personal injury or death.

WARNING

Failure to ensure that the hoisting sling is capable of handling the full weight of the container and contents may result in damage to container. Improper placement of sling onto container could result in the container unit sliding out of sling, causing personal injury or death.

WARNING

Failure to ensure that both T-pins have been removed from either side of the generator slide before attempting to remove generator may cause damage to the equipment.

HAZARDOUS MATERIALS DESCRIPTION



WARNING

In the event of lamp breakage, care must be taken in removal of broken glass fragments and dust that may be dispersed within fixture. Inhalation of dust could cause dangerous injury. Ensure area is well ventilated.

Cleanup requires special care due to mercury droplet proliferation. Contact your supervisor for disposal guidance.

WARNING

Isopropyl alcohol, dry cleaning solvents, and toluene are flammable and harmful to eyes, skin, and breathing passages. Observe all fire precautions. Use only with adequate ventilation and with approved personal protective equipment.

WARNING

PermaBond 268 is flammable and will bond to eyelids, skin, and mouth. Skin and eye protection are required. Avoid repeated/prolonged contact. Good, general ventilation is normally adequate.

WARNING

Cloths used to wipe up spills may cause rapid polymerization that could generate sufficient heat to ignite the cloth. Immediately soak cloth with water to polymerize the adhesive. Combustion may release noxious or toxic vapors. Use polyethylene gloves. Do not wear rubber or cloth gloves.

TM 9-4910-783-13&P

WARNING

No attempt should be made to remove material from skin or to remove contaminated clothing, as the bonded skin can easily be torn. Wash with large volumes of soap and water while flexing bonded skin parts. This procedure will slowly release bonded areas.

WARNING

Do not mechanically remove cured adhesive or attempt to pull skin apart.

WARNING

Dowclene EC (6K748) is flammable and harmful to eyes, skin, and breathing passages. Observe all fire precautions. Use only with adequate ventilation and with approved personal protective equipment.

WARNING

PRC 1422 B-2 sealant (7D294) is flammable and harmful to eyes, skin, and breathing passages. Observe all fire precautions. Use only with adequate ventilation and with approved personal protective equipment.

WARNING

EA9324 Adhesive (IJB33) is flammable and harmful to eyes, skin, and breathing passages. Observe all fire precautions. Use only with adequate ventilation and with approved personal protective equipment. Keep away from open flames or other sources of ignition.

WARNING

Do not use plastic container for mixing. Heat generated by mixed material may result in melting of container and may cause burns. Mix the epoxy resin (EA828) and diethylenetriamine activator (O-D-1271) in a well ventilated area. The vapor produced is toxic. Avoid breathing vapors and avoid skin contact with the mixture. If the adhesive contacts the skin, flush area with warm water and soap.

WARNING

Chemicals in the resins and catalysts may also cause discomfort if prolonged contact is made with the skin. Read all instructions carefully and observe good safety practices. Smoking should be prohibited in the immediate area while working with resins and solvents

WARNING

Do not pour chemicals or paste into sinks, toilets or garbage containers. Material could set up and clog drains or cause fire in containers having flammable contents, oily rags, etc.

TM 9-4910-783-13&P

SAFETY SUMMARY

The following definitions apply to WARNINGS and CAUTIONS found throughout this publication.

WARNING

An operation or maintenance procedure, practice, condition, statement, which if not strictly observed, could result in injury, death, or long term hazards to personnel.

CAUTION

An operation or maintenance procedure, practice, statement, which, if not strictly observed could result in damage/destruction of equipment or loss of mission effectiveness.

GENERAL PRECAUTIONS

The following are general precautions that are not related to any specific procedure and therefore do not appear elsewhere in this publication. These are recommended precautions that personnel must understand and apply during many phases of operation and maintenance.

CLEANERS AND CHEMICALS

Keep in approved safety containers and in minimum quantities. Some cleaners and chemicals may have an effect on skin, eyes, and respiratory tract. Observe manufacturer's WARNING labels and current safety directives. Use only in authorized areas. Discard soiled cleaning cloths into safety cans. Unless otherwise indicated in the text, use as described in this TM should not result in any immediate health concerns. Consult the local Bioenvironmental Engineer for specific protective equipment and ventilation requirements.

TOXIC MATERIALS

Primers and paints are flammable and toxic to skin, eyes, and respiratory tract. Skin and eye protection required. Avoid repeated or prolonged contact. Good general ventilation is normally adequate.

COMPRESSED AIR

Use of compressed air can create an environment of propelled foreign particles. Air pressure shall be reduced to less than 30 psig (207 kilopascals) and used with effective chip guarding and personal protective equipment (goggles/shield, gloves, etc).

TM 9-4910-783-13&P

INSERT LATEST CHANGED PAGES. DESTROY SUPERSEDED DATA

LIST OF EFFECTIVE PAGES

NOTE: The portion of text affected by the changes is indicated by a vertical line in the outer margins of the page.

Dates of issue for original and changed pages are:

Original0..... 30 September 2005

TOTAL NUMBER OF PAGES IN THIS PUBLICATION ARE 506, CONSISTING OF THE FOLLOWING:

Page/WP No.	*Change No.	Page/WP No.	*Change No.
Cover	0	WP 0034 00	
Warnings a-e	0	WP 0035 00	
LOEP	0	WP 0036 00	
i-iv	0	WP 0037 00	
Chapter 1 Title Page		WP 0038 00	
WP 0001 00		WP 0039 00	
WP 0002 00		WP 0040 00	
Chapter 2 Title Page		WP 0041 00	
WP 0003 00		WP 0042 00	
WP 0004 00		WP 0043 00	
WP 0005 00		WP 0044 00	
WP 0006 00		WP 0045 00	
WP 0007 00		WP 0046 00	
Chapter 3 Title Page		WP 0047 00	
WP 0008 00		WP 0048 00	
WP 0009 00		FO-1	
Chapter 4 Title Page		FO-2	
WP 0010 00		Chapter 5 Title Page	
WP 0011 00		WP 0049 00	
WP 0012 00		WP 0050 00	
WP 0013 00		WP 0051 00	
WP 0014 00		WP 0052 00	
WP 0015 00		WP 0053 00	
WP 0016 00		WP 0054 00	
WP 0017 00		WP 0055 00	
WP 0018 00		WP 0056 00	
WP 0019 00		WP 0057 00	
WP 0020 00		Glossary-1	
WP 0021 00		INDEX-1 thru INDEX 6	
WP 0022 00		Appendix A Title Page	
WP 0023 00		WP 0058 00	
WP 0024 00		Appendix B Title Page	
WP 0025 00		WP 0059 00	
WP 0026 00		Appendix C Title Page	
WP 0027 00		WP 0060 00	
WP 0028 00			
WP 0029 00			
WP 0030 00			
WP 0031 00			
WP 0032 00			
WP 0033 00			

*Zero in this column indicates an original page.

A/(B blank)

TM 9-4910-783-13&P

HEADQUARTERS
DEPARTMENT OF THE ARMY
Washington, DC, 30 September 2005

**TECHNICAL MANUAL
OPERATOR'S, UNIT, AND DIRECT SUPPORT MAINTENANCE MANUAL
(INCLUDING REPAIR PARTS AND SPECIAL TOOLS LIST)
FOR
STANDARD AUTOMOTIVE TOOL SET
CONTRACT # DAAE20-03D-0085
NSN 4910-01-490-6453
FIELD MAINTENANCE MODULE 1
NSN 4910-01-501-7342
FIELD MAINTENANCE MODULE 2
NSN 4910-01-501-7343**

REPORTING ERRORS AND RECOMMENDING IMPROVEMENTS

You can help improve this publication. If you find any mistakes or if you know of a way to improve the procedures, please let us know. Submit your DA Form 2028 (Recommended Changes to Equipment Technical Publications), through the Internet, on the Army Electronic Product Support (AEPS) website. The Internet address is <https://aeeps.ria.army.mil>. The DA Form 2028 is located under the Public Applications section in the AEPS Public Home Page. Fill out the form and click on SUBMIT. Using this form on the AEPS will enable us to respond quicker to your comments and better manage the DA Form 2028 program. You may also mail, fax or E-mail your letter or DA Form 2028 direct to: AMSTA-LC-LMIT / TECH PUBS, TACOM-RI, 1 Rock Island Arsenal, Rock Island, IL 61299-7630. The email address is TACOM-TECH-PUBS@ria.army.mil. The fax number is DSN 793-0726 or Commercial (309) 782-0726.

DISTRIBUTION STATEMENT A - Approved for public release; distribution is unlimited.

COPYRIGHT RELEASE – Kipper Tools, 2375 Murphy Blvd., Gainesville, Georgia 30504 has given the Government permission to copy and distribute to Government agencies TM 9-4910-783-13&P.

HEADQUARTERS, DEPARTMENT OF THE ARMY

TM 9-4910-783-13&P

TABLE OF CONTENTS

WP Sequence No.

WARNING SUMMARY	a
LIST OF EFFECTIVE PAGES/WORK PACKAGES	A
TABLE OF CONTENTS	ii
HOW TO USE THIS MANUAL	iv
CHAPTER 1 – INTRODUCTION	
General Information	0001 00
Theory of Operation	0002 00
CHAPTER 2 - OPERATING INSTRUCTIONS	
Equipment Description and Data	0003 00
Description and Use of Operator's Controls and Indicators.....	0004 00
Operation Under Usual Conditions	0005 00
Operation Under Unusual Conditions	0006 00
On-Vehicle Equipment Loading Plan	0007 00
CHAPTER 3 - TROUBLESHOOTING PROCEDURES	
Field (Operator) Troubleshooting Procedures	0008 00
Field (Unit) Maintenance Troubleshooting Procedures	0009 00
CHAPTER 4 - MAINTENANCE INSTRUCTIONS	
Field (Unit) Preventive Maintenance Checks and Services (PMCS) Introduction	0010 00
Repair Parts, Special Tools, TMDE, & Support Equipment.....	0011 00
Field (Operator) Maintenance Procedures	
General	0012 00
Area Light Assembly Removal and Installation	0013 00
Ceiling Light: Lens, Fluorescent Tube, Ballast, & Fixture Removal and Installation	0014 00
ECU Repair, Removal, and Installation	0015 00
Generator Repair, Removal, and Installation.....	0016 00
Generator Access Panels Removal and Installation	0017 00
Field (Unit) Maintenance Procedures	0018 00
Generator Slide Caster Removal and Installation.....	0019 00
Generator Slide Removal and Installation	0020 00
Generator Slide Frame Removal and Installation.....	0021 00
ECU Slide Removal and Installation	0022 00
Personnel Door Internal Handle and Locking Bar Removal and Installation.....	0023 00
Panel Hasp Removal and Installation.....	0024 00
Computer Cabinet Removal and Installation	0025 00
Main Generator Cable Removal and Installation	0026 00
Circuit Breaker Panel Assembly Removal, Repair, and Installation	0027 00
Power Input Receptacle Assembly Removal, Repair, and Installation	0028 00
Communication Panel Assembly Removal and Installation.....	0029 00
Utility Step Removal and Installation	0030 00
Blackout Light Assembly Removal, Repair, and Installation.....	0031 00
Ceiling Light Removal, Repair, and Installation	0032 00
Internal Receptacle Outlets Removal, Repair, and Installation	0033 00
Wall Switch Removal and Installation	0034 00
Limit Switch Removal, Repair, Installation, and Adjustment.....	0035 00
Wiring Removal, Repair, and Installation.....	0036 00

TM 9-4910-783-13&P

TABLE OF CONTENTS

	<u>WP Sequence No.</u>
Rivet Removal and Installation	0037 00
Door Gasket Removal and Installation	0038 00
Main Door Removal and Installation	0039 00
Repair of Dents or Depressions – Aluminum Bonded Material	0040 00
Repair of Puncture Less than ½ in – Aluminum Bonded Material	0041 00
Repair of Fracture Less than 1-½ x 3 in – Aluminum Bonded Material	0042 00
Rivnut Repair	0043 00
Container Lift Jack Assembly Removal and Installation	0044 00
Caulking Repaired Areas	0045 00
Paint Refinishing	0046 00
Preparation for Shipment and Storage	0047 00
Wiring Diagrams	
Wire List	0048 00
Electrical System Schematic Diagram – Power Input Panel.....Foldout (FO)-1 Sheet 1 of 2	
Electrical System Schematic Diagram – Switches and Outlets.....FO-1 Sheet 2 of 2	
Electrical System Schematic Diagram – Communication Panel..... FO-2	
CHAPTER 5 - SUPPORTING INFORMATION	
References	0049 00
Maintenance Allocation Chart (MAC) – Introduction.....	0050 00
Maintenance Allocation Chart (MAC)	0051 00
Tool and Test Equipment Requirements	0052 00
Repair Parts and Special Tools List.....	0053 00
Parts List Order Form.....	0054 00
Instructions for Requisitioning Parts from Commercial Source	0055 00
Components of End Item and Basic Issue Items Lists	0056 00
Expendable and Durable Items List	0057 00
GLOSSARY	Glossary-1
INDEX	INDEX-1
APPENDICES	
APPENDIX A - BASE TOOLS INVENTORY GUIDE	0058 00
APPENDIX B - FIELD MAINTENANCE MODULE 1 (FMM1) TOOLS INVENTORY GUIDE.....	0059 00
APPENDIX C - FIELD MAINTENANCE MODULE 2 (FMM2) TOOLS INVENTORY GUIDE	0060 00

TM 9-4910-783-13&P

HOW TO USE THIS MANUAL

This manual explains how to operate and maintain the Standard Automotive Tool Set (SATS).

1. Take a few minutes to look through this manual. We've designed this manual to make it easier for you to find and perform the procedure you need.
 - a. Chapters are divided by chapter title pages.
 - b. References are noted where applicable.
 - c. Figures are located as close as possible to their references.
2. If the SATS container needs repair and you know what is wrong with it, here is what you do:
 - a. Turn to the Index or Table of Contents and check for a paragraph or work package on the component you want to remove and replace.
 - b. Turn to the paragraph. Under the paragraph title, you will find the tools, materials, and equipment condition needed to perform the procedure. If an equipment condition is needed to prepare the SATS container component for the removal procedure, it will be noted. If the procedure requires referencing another task or section, it will be noted.
 - c. To remove bad components, follow the removal procedure.
 - d. To install the new component, perform the installation procedure. The SATS container should now be ready to operate.
 - e. Perform the applicable troubleshooting procedures to verify the repair of the SATS container component.
3. If the SATS container needs repair and you do not know what is wrong with it, go to the troubleshooting procedures. Identify the malfunction and locate it in the troubleshooting table. Then perform the tests/inspections and corrective actions in the order listed. If the malfunction is not listed in the troubleshooting table or is not corrected by the corrective action listed, notify the next higher level of maintenance.

TM 9-4910-783-13&P

CHAPTER 1
INTRODUCTION
FOR
STANDARD AUTOMOTIVE TOOL SET (SATS)

TM 9-4910-783-13&P



Figure 1-1. Standard Automotive Tool Set

TM 9-4910-783-13&P

STANDARD AUTOMOTIVE TOOL SET (SATS)

0001 00

GENERAL INFORMATION

SCOPE

Type of Manual. This technical manual includes field (operator, unit, and direct support) maintenance procedures for the Standard Automotive Tool Set (SATS). It also includes a list of repair parts and special tools.

Equipment Name and Model Number. This technical manual covers the Standard Automotive Tool Set. The Standard Automotive Tool Set is capable of including SATS base tool set, field maintenance module one tool set and field maintenance module two tool set.

Purpose of Equipment. The Standard Automotive Tool Set, Figure (Fig) 1-1, is designed to sustain a wide variety of tactical and combat equipment on the battlefield, primarily automotive vehicles. The SATS is a self-contained, integrated unit, equipped for safe performance of a variety of maintenance and maintenance-related tasks. It consists of a dismountable trailer-mounted container (capable of stand-alone or trailer-mounted operation) containing the tools and equipment needed to fulfill required maintenance actions.

MAINTENANCE FORMS, RECORDS, AND REPORTS

Reports of Maintenance and Unsatisfactory Equipment. Department of the Army forms and procedures used for equipment maintenance will be those prescribed by Department of the Army Pamphlet (DA PAM) 750-8.

Reporting of Item and Packaging Discrepancies. Fill out and forward Standard Form (SF) 364 (Report of Discrepancy (ROD)) as prescribed in AR 735-11-2.

Transportation Discrepancy Report (TDR) (SF 361). Fill out and forward Transportation Discrepancy Report (TDR) (SF 361) as prescribed in AR 55-38.

REPORTING EQUIPMENT IMPROVEMENT RECOMMENDATIONS (EIR)

If your equipment needs improvement, let us know. Send us an EIR. You, the user, are the only one who can tell us what you don't like about your equipment. Let us know why you don't like the design or performance. Submit via Army Electronic Product Support System (AEPS). Instructions for submitting via AEPS are as follows:

1. Go to <http://aeprs.ria.army.mil> and click on "Accept" option. On next page, scroll down page and click on "Submit Quality Deficiency Report". Following the instructions complete form and click on "Submit Report".
2. You will receive an email confirming receipt of your report and a second email providing the name, phone number, and email address of the action officer assigned to your report. At any time you wish, you may return to the "Customer Submissions" section and click on "Review Status" to check on the status of your report.

TM 9-4910-783-13&P

REPORTING EQUIPMENT IMPROVEMENT RECOMMENDATIONS (EIR) (cont)

3. Optional. You may request an AEPS ID and password (not required for submitting QDRs). Here's how:

- a. Go to <http://aeps.ria.army.mil> and click on "Accept" option.
- b. On the next page click on "Access Request Form." Read the page and select one of the 3 options (Access request for non-CAC users will probably be the most common). Click on "Continue on to the Access Request Form."
- c. Select one of the options on this page and click on Continue. Complete application form. When form is completed an email will be automatically sent to your supervisor, who must approve your application. Then, an email will be sent to the AEPS system administration office, which will send you a user ID via email within two working days.
- d. With your ID, return to <http://aeps.ria.army.mil>. Click on "Accept." On next page click on "Enter AEPS." A window will open into which you will enter your ID and a password of your choosing (following the rules on the screen) and then click on "OK." Remember your ID and password for future use.
- e. Scroll down the page and click on "Electronic Deficiency Reporting System." On left hand side under "Customer Submissions," you have the choice to click on "New Report" or "Review Status" (which will show current status of your submitted QDRs).

Alternate methods for submitting QDRs:

1. Via Email to: QAWQDRS@RIA.ARMY.MIL
2. Via Fax to: (309) 782-6653 or DSN 793-6653
3. Hardcopy to: RDECOM-ARDEC
AMSRD-AAR-QEP-C (S. MATLICK)
BLDG 62, 2ND FLOOR
1 ROCK ISLAND ARSENAL
ROCK ISLAND, IL 61299-7300

CORROSION PREVENTION AND CONTROL (CPC)

Corrosion Prevention and Control (CPC) of Army material is a continuing concern. It is important that any corrosion problems with this item be reported so that the problem can be corrected and improvement can be made to prevent the problem in future items.

While corrosion is typically associated with rusting of metals, it can also include deterioration of other materials, such as rubber and plastic. Unusual cracking, softening, swelling, or breaking of these materials may be a corrosion problem. If a corrosion problem is identified, it can be reported using SF 368, Product Quality Deficiency Report. Use of key words, such as "corrosion", "rust", "deterioration", or "cracking" will ensure that the information is identified as a CPC problem.

The form should be submitted to the address specified in DA PAM 750-8, The Army Maintenance Management System (TAMMS) Users Manual.

TM 9-4910-783-13&P

STANDARD AUTOMOTIVE TOOL SET (SATS)

0001 00

DESTRUCTION OF ARMY MATERIAL TO PREVENT ENEMY USE

Refer to TM-750-244-3, Procedures for Destruction of Equipment to Prevent Enemy Use, for information about destruction.

PREPARATION FOR STORAGE OR SHIPMENT

For information on preparation for storage or shipment, refer to WP 0047.

WARRANTY INFORMATION

The container is warranted for a period of one year. Tools provided with container are commercial items. Warranties for individual tools can be found in the COTS literature associated with tool. The warranty starts on date found in block 23 of DA Form 2408-9, Equipment Control Record. Report all defects to your supervisor, who will take appropriate action.

LIST OF ABBREVIATIONS/ACRONYMS

AC	Air Conditioner
AEPS	Army Electronic Product Support System
BNC	Bayonet Nut Connector
BTU	British Thermal Unit
CARC	Chemical Agent Resistant Coating
CB	Circuit Breaker
Cm	centimeter
COTS	Commercial Off-The-Shelf
CPC	Corrosion Prevention Control
CSC	Container Safety Convention
DA PAM	Department of the Army Pamphlet
ECU	Environmental Control Unit
EIR	Equipment Improvement Recommendation
Fig	Figure
FMM	Field Maintenance Module
FO	Foldout
FRP	Fiberglass Reinforced Plastic

TM 9-4910-783-13&P

STANDARD AUTOMOTIVE TOOL SET (SATS)

0001 00

LIST OF ABBREVIATIONS/ACRONYMS (cont)

ft	foot (feet)
GAA	Grease, Automotive and Armament
GFM	Government Furnished Material
GMTK	General Mechanic's Tool Kit
GND	Ground
Hr	Hour
Hz	Hertz
in.	Inch
ISO	International Organization for Standardization
kg	kilogram
Kw	kilowatt
lb	pound
lg	long
LH	left-hand
MAC	Maintenance Allocation Chart
MIL	Military
mm	millimeter
MTOE	Modified Table of Organization and Equipment
No.	number
NSN	National Stock Number
P	Parts
PMCS	Preventive Maintenance Checks and Services
Pg	Page
QDR	Quality Deficiency Report

TM 9-4910-783-13&P

STANDARD AUTOMOTIVE TOOL SET (SATS)

0001 00

LIST OF ABBREVIATIONS/ACRONYMS (cont)

ref	reference
RH	right-hand
RJ	Registered Jack
ROD	Reporting of Item and Packaging Discrepancies
RS	Recommended Standard
SATS	Standard Automotive Tool Set
SF	Standard Form
sq	square
TAMMS	The Army Maintenance Management System
TDR	Transportation Discrepancy Report
TM	Technical Manual
TMDE	Test, Measurement and Diagnostic Equipment
VAC	Volts, alternating current
WP	Work Package

QUALITY OF MATERIAL

Material used for replacement, repair, or modification must meet the requirements of TM 9-4910-783-13&P. If quality of material requirements are not stated in TM 9-4910-783-13&P, the material must meet requirements of drawings, standards, specifications, or approved engineering change proposals applicable to subject equipment.

END OF WORK PACKAGE

TM 9-4910-783-13&P

STANDARD AUTOMOTIVE TOOL SET (SATS)

0002 00

THEORY OF OPERATION

The Standard Automotive Tool Set (SATS) is a self-contained modular, flexible, standardized tool set that will replace the most numerous types of field level shop sets. It will be used in the performance of preventive maintenance checks and services, diagnosis of equipment faults, and repairing of equipment. The primary mission of SATS is field level maintenance of military vehicles and ground support equipment.

END OF WORK PACKAGE

TM 9-4910-783-13&P

CHAPTER 2
OPERATING INSTRUCTIONS
FOR
STANDARD AUTOMOTIVE TOOL SET (SATS)

TM 9-4910-783-13&P

STANDARD AUTOMOTIVE TOOL SET (SATS)

0003 00

EQUIPMENT DESCRIPTION AND DATA

EQUIPMENT CHARACTERISTICS, CAPABILITIES, AND FEATURES

Capabilities and Features:

- Equipped with standard ISO fittings for easy transportability
- Built-in forklift provisions
- All weather operation
- Environmentally controlled interior
- Rigid wall construction
- Simple and fast deployment
- Designed to operate under blackout conditions with door activated blackout switch
- External electrical power connection
- Easy to maintain



Figure 2-1. Standard Automotive Tool Set (SATS)

LOCATION AND DESCRIPTION OF MAJOR COMPONENTS

1. CONTAINER PANELS. Made of an aluminum tube and fiberglass reinforced plastic (FRP) tube skeleton, an aluminum alloy interior face sheet, polyisocyanurate foam core, and an aluminum alloy exterior face sheet bonded together to form a rigid panel. Panels are built around an aluminum frame structure. Plates are fastened to bottom surface of frame and serve as a beam. The bottom face of base serves as a bearing surface for roller conveyor systems of aircraft cargo handling systems.

Exterior surfaces of walls and roof painted with MIL-C-53039 Chemical Agent Resistant Coating (CARC) paint. Access openings for pass-through panels for electrical inputs, as well as openings for the ECU are provided in appropriate panels of container. All such openings are framed with extruded aluminum members, which are permanently bonded/sealed to affected panel.

TM 9-4910-783-13&P

LOCATION AND DESCRIPTION OF MAJOR COMPONENTS (cont)

2. PERSONNEL DOOR. Access into and from container is provided by a 48 inches (1219 mm) wide personnel entrance door. It is equipped with an externally pad lockable handle that includes a safety release mechanism. In the event that a person should become trapped inside container when outside handle has been padlocked, a quick release pin can be removed, decoupling interior handle from padlocked exterior handle, allowing exit from container.
3. FORK POCKETS. Located in each long side of base are two fork openings, formed by aluminum alloy tubes integral to base spanning its width. These tubes accommodate up to 12-inch (305mm) fork truck tines at 81 inches (2057mm) nominal center-to-center spacing.
4. INTERNAL AIR TRANSPORT RESTRAINT RAILS. Restraint rails are provided with SATS to base of container to facilitate transport in military cargo transport aircraft like the C-5, C-17, C-130, and C-141. Additional information regarding air transport of container appears in WP 0007 00, Moving Container in Transport Aircraft.
5. INTERNATIONAL ORGANIZATION FOR STANDARDIZATION (ISO) CORNERS. Lifting, towing and tying provisions are located on eight (8) corner strong points of container structure to facilitate movement of container by crane, hoist, helicopter, or similar means.
6. MECHANICAL ROOM. Provides housing for electric power generator and ECU. Access doors provide accessibility to ECU and generator system for maintenance and repair. A floor drain is included to facilitate drainage of water and other liquids from compartment.
7. ROOF ACCESS STEPS. Five foldout steps are located on right side of container. They provide a convenient foothold and handhold when climbing to container roof.
8. POWER INPUT RECEPTACLE. A service entrance connector on this panel receives external primary input power for container and routes it to a circuit breaker panel inside container. Includes provisions for optional container grounding.
9. AREA LIGHTS. There are two area lights for the SATS. They can be placed on ground using tripod legs. They are both stored on inside of personnel door.
10. CIRCUIT BREAKER PANEL. Provides overload protection for container circuits. Main circuit breaker switches off all electrical power to container. Circuit breaker panel is located on RH side wall inside container.
11. COMMUNICATIONS PANEL. Contains (2) RJ-45, (1) RS242, (1) Serial Port Connector, (2) Black BNC connectors and (2) Red BNC connectors.
12. COMPUTER WORK STATION. A steel cabinet with keyboard drawer and lockable doors to house computer. Computer work station is located on RH side wall inside container.
13. TOOL RACKS. Series of racks with aluminum frame. Foam padded drawers in all but the Loose Tools Rack house SATS components.
14. ECU. GFM item. 9,000 British thermal unit (BTU)/hour (Hr), 208V, 3 phase, 50/60 Hertz, Air conditioner (NSN 4120-01-193-4998).
15. GENERATOR. GFM item. 10 kilowatt (Kw), 60 Hz, Tactical Quiet (MEP-803A, NSN 6115- 01-275-5061).

TM 9-4910-783-13&P

LOCATION AND DESCRIPTION OF MAJOR COMPONENTS (cont)

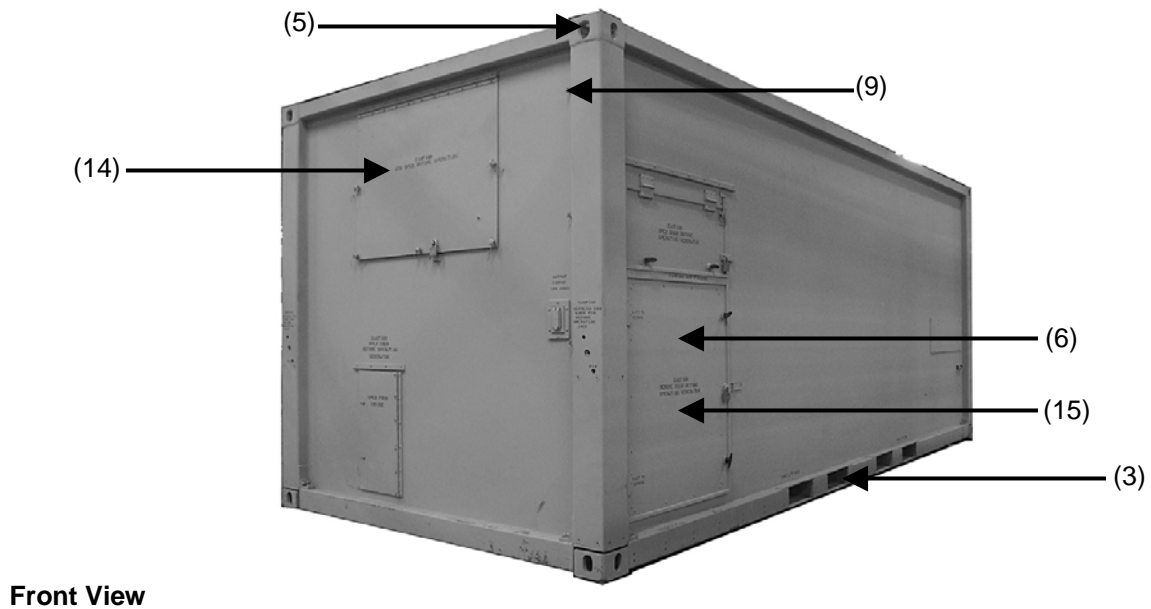
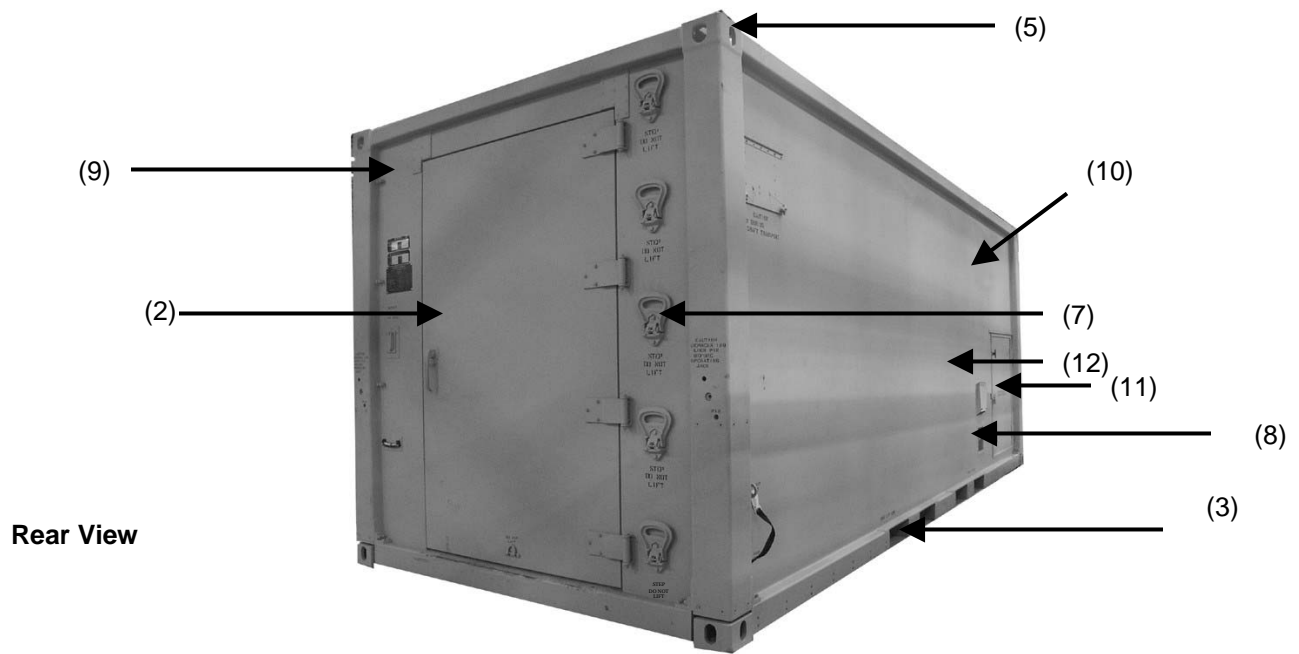

Figure 2-2. Full external view of SATS

TM 9-4910-783-13&P

STANDARD AUTOMOTIVE TOOL SET (SATS)

0003 00

EQUIPMENT DATA

Exterior Dimensions (Closed-Shipping Configuration)

Width 8 ft. (2.44 meters)
Height 8 ft. (2.44 meters)
Length 19 ft., 10½ in. (6.05 meters)

Interior Dimensions

Minimum clear height 85.81 in. (2.18 meters)
Minimum clear width 86.75 in. (2.20 meters)
Usable floor space 111.50 sq.ft. (10.6 sq.meters)

Total Weights

Configuration: Base, FMM1, FMM2

Less payload 6,300 lbs (2858 Kg)
With payload (maximum) 14,030 lbs (6377 Kg)

Configuration: Base, FMM1

Less payload 6,300 lbs (2858 Kg)
With payload (maximum) 13,040 lbs (5927 Kg)

Configuration: Base

Less payload 6,300 lbs (2858 Kg)
With payload (maximum) 10,380 lbs (4718 Kg)

Electrical Requirements

Primary Electrical Supply 120/208 VAC, 60 Hz, 3 phase

Environmental Limits

Operating temperature -25°F to +120°F (-31.7°C to 48.9°C)

Transportability

ISO fittings Provided with upper and lower ISO fittings in accordance with specification ISO 1496/1

Fork Lift Built-in forklift provisions.

Trailer 7.5 ton Payload, 20' ISO container trailer (Part No.1103-1000-00)

END OF WORK PACKAGE

TM 9-4910-783-13&P

DESCRIPTION AND USE OF OPERATOR CONTROLS AND INDICATORS

SCOPE

This section provides description and use of operator controls and indicators, circuit breaker panel controls and indicators, and personnel end panel mounted controls and indicators needed to operate container.

CIRCUIT BREAKER PANEL CONTROLS AND INDICATORS

Table 2-1. Circuit Breaker Panel Controls and Indicators

	Nomenclature	Function
Controls and Indicators (Fig. 2-3)		
21	Main Circuit Breaker	In ON position, delivers electrical power to individual circuit breakers. In OFF position, turns off all electrical power in container.
2	Circuit Breaker	Provides overload protection for incandescent and fluorescent lights, and blackout circuit mounted on fixed personnel end wall.
3	Circuit Breaker	Provides overload protection for ECU.
4	Circuit Breaker	Provides overload protection for interior utility outlets mounted on the RH (curbside) sidewall
6	Circuit Breaker	Provides overload protection for interior utility outlets mounted on the LH (roadside) sidewall
8	Circuit Breaker	Provides overload protection for exterior utility outlet (which is also ground fault protected).
9	Circuit Breaker	Provides overload protection for air compressor
10	Circuit Breaker	Provides overload protector for carbon monoxide detector

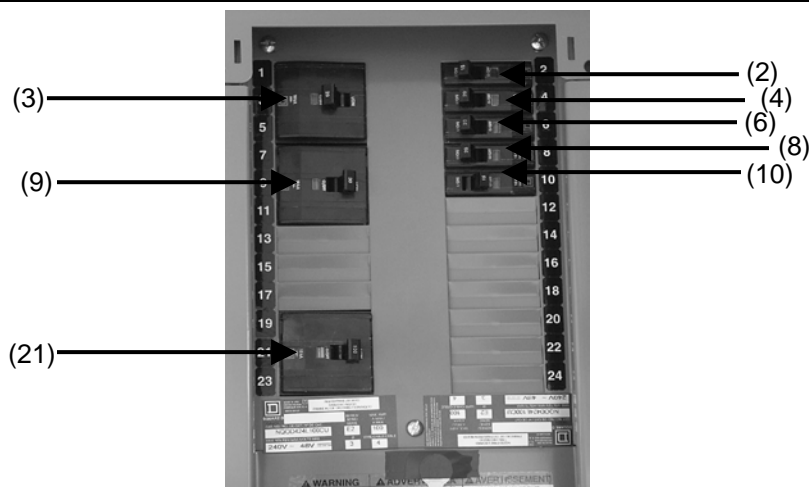

Figure 2-3. Circuit Breaker Panel

TM 9-4910-783-13&P

STANDARD AUTOMOTIVE TOOL SET (SATS)

0004 00

PERSONNEL END PANEL MOUNTED CONTROLS AND INDICATORS

Table 2-2. Personnel End Panel Mounted Controls and Indicators

	Nomenclature	Function
Controls and Indicators (Fig. 2-4)		
1	Door activated blackout switch	During blackout conditions it turns off all fluorescent (white) and turns on all incandescent (blue) lights in container when troop entry door is open. To override operation of this switch, blackout switch must be in Blackout position. Circuit protected against overload by circuit breaker.
2	Blackout override switch	In Blackout position, overrides door activated blackout switch mounted on troop door end wall. During blackout conditions, must be in Override position. Circuit protected against overload by circuit breaker.
3	Ceiling lights switch	In ON position, turns on three fluorescent light fixtures in container. In OFF position turns off all fluorescent lights. Circuit protected against overload by circuit breaker.

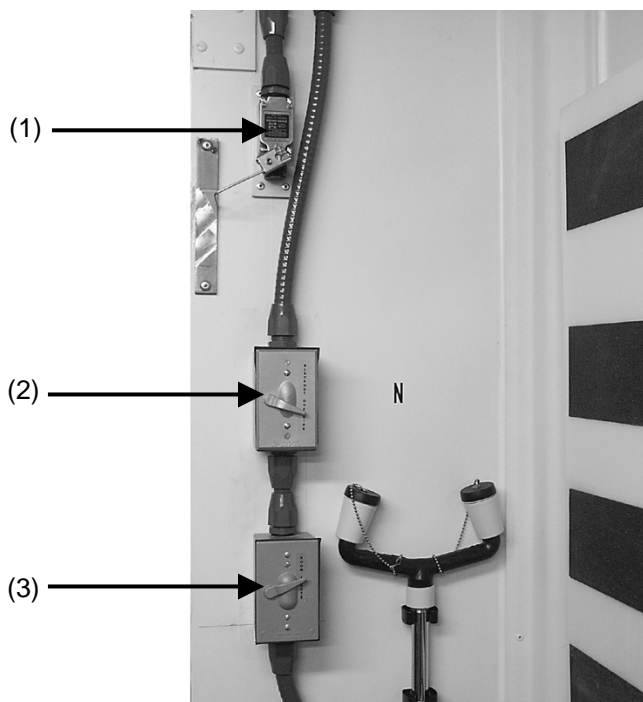

Figure 2-4. Personnel end panel mounted controls and indicators.

END OF WORK PACKAGE

TM 9-4910-783-13&P

STANDARD AUTOMOTIVE TOOL SET (SATS)

0005 00

OPERATION UNDER USUAL CONDITIONS

NOTE

If equipment fails to operate, refer to troubleshooting procedures in Chapter 3.

SECURITY MEASURES FOR ELECTRONIC DATA

A lockable computer cabinet is provided in container.

SITE REQUIREMENTS

Select a site that:

- Has reasonable maneuvering area for vehicles that will be used for hauling or hoisting container.
- The terrain is firm, well drained, and relatively free of surface rocks or stones.
- The slope of terrain does not exceed 18 inches (45.7 cm) over floor area of container.

CONTAINER INSPECTION

1. Inspect container for damage incurred during shipment. If container has been damaged, report damage on SF 361, Transportation Discrepancy Report.
2. Check equipment against packing list to see if shipment is complete. Report all discrepancies in accordance with instructions of DA PAM 750-8.
3. Inspect container in accordance with Container Inspection Checklist (Table 2-3).

TM 9-4910-783-13&P

STANDARD AUTOMOTIVE TOOL SET (SATS)

0005 00

CONTAINER INSPECTION CHECKLIST

Table 2-3. Inspection Checklist

	LOCATION	ITEM	ACTION
1	Fixed personnel end wall	<ul style="list-style-type: none"> a. Identification and instruction plates and stencils b. Personnel door c. Folding steps d. Door hardware e. Skin f. CSC plate 	<p>Check for legibility or missing plates</p> <p>Check for security and condition of door, locks, seals, and shims</p> <p>Check for security and condition</p> <p>Inspect for missing, bent, or damaged components</p> <p>Inspect skin surface for paint damage, corrosion, cracks, or punctures</p> <p>Check for legibility or missing plate</p>
2	Roof	<ul style="list-style-type: none"> a. Upper ISO fittings b. Skin 	<p>Inspect for damage</p> <p>Inspect skin surface for paint damage, corrosion, cracks, or punctures</p>
3	ECU end wall	<ul style="list-style-type: none"> a. Doors b. Components c. Skin d. Identification and stencils 	<p>Check for condition of latches, seals, and panels</p> <p>Inspect for missing, bent, or damaged components</p> <p>Inspect surface for paint damage, corrosion, cracks, or punctures</p> <p>Check for legibility or missing plates</p>
4	ISO frame	<ul style="list-style-type: none"> a. Lower ISO fittings b. Frame edge and forklift opening c. Corner posts 	<p>Inspect for damage</p> <p>Inspect for damage</p> <p>Inspect for damage</p>

TM 9-4910-783-13&P

Table 2-3. Inspection Checklist (cont)

5	RH sidewall	ITEM	ACTION
		<ul style="list-style-type: none"> a. Power input receptacle b. Decompression vent door c. Generator tunnel access door d. Components e. Skin f. Identification and stencils 	<ul style="list-style-type: none"> Inspect connectors for damage Inspect seals and knobs for damage Inspect seals and knobs for damage Inspect for missing, bent, or damaged components Inspect surface for paint damage, corrosion, cracks, or punctures Check for legibility or missing plates
6	LH sidewall	<ul style="list-style-type: none"> a. Generator tunnel access door b. Components c. Skin d. Identification and stencil 	<ul style="list-style-type: none"> Inspect for damage Inspect for missing, bent, or damaged components Inspect surface for paint damage, corrosion, cracks, or punctures Check for legibility or missing plate
7	Corner posts	<ul style="list-style-type: none"> a. Components 	<ul style="list-style-type: none"> Inspect for missing, bent, or damaged components
8	Electrical	<ul style="list-style-type: none"> a. Fixtures b. Conduit 	<ul style="list-style-type: none"> Inspect for damage Inspect for damage
9	Racks/drawers	<ul style="list-style-type: none"> a. Skin b. Hardware 	<ul style="list-style-type: none"> Inspect surface for paint damage, corrosion, cracks, or punctures Ensure the drawer is functioning properly

TM 9-4910-783-13&P

STANDARD AUTOMOTIVE TOOL SET (SATS)

0005 00

SETUP

NOTE

If the SATS has been closed for more than 48 hours, open it and allow it to air out 10 minutes prior to entry.

Container can be employed in two ways; on trailer or on ground. Two ramps are provided with container. Depending on where container is to be utilized, the 4' x 4' or 4' x 14' ramp must be attached.

INSTALLATION OF 4' X 14' RAMP

NOTE

The 4' x 14' ramp is to be employed only while container is loaded on trailer.

The ramp storage compartment is located directly below personnel door. Follow steps below to remove ramp from storage and attach it to container:

1. Unlatch storage compartment door.

CAUTION

Ramp requires a four-person lift.

2. Remove ramp by grabbing handles (1) and pulling it straight out (Fig. 2-5).

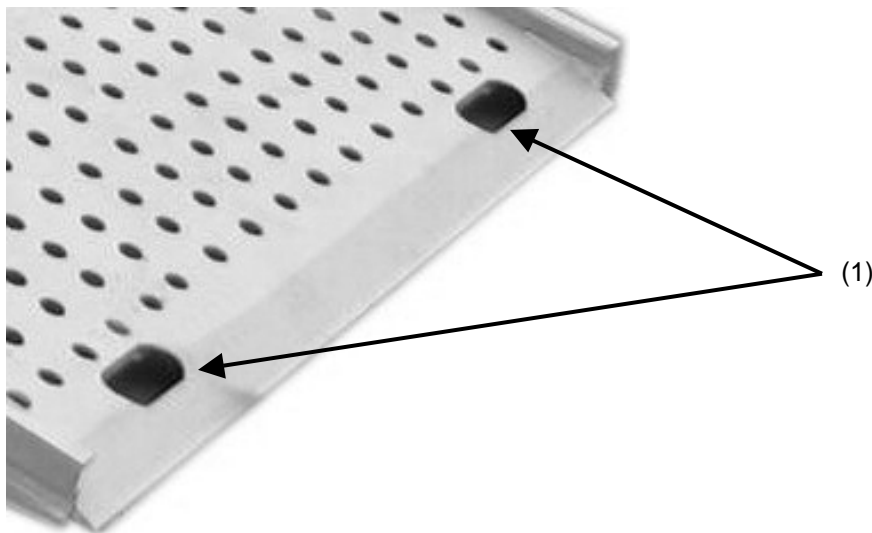

Figure 2-5. 4' x 14' ramp handles.

TM 9-4910-783-13&P

INSTALLATION OF 4' X 14' RAMP (cont)

3. Once ramp is completely out of storage compartment, lift end closest to container and attach it by placing pegs (1) on bottom of ramp (Fig. 2-6) in holes (1) at bottom of personnel door (Fig. 2-7).

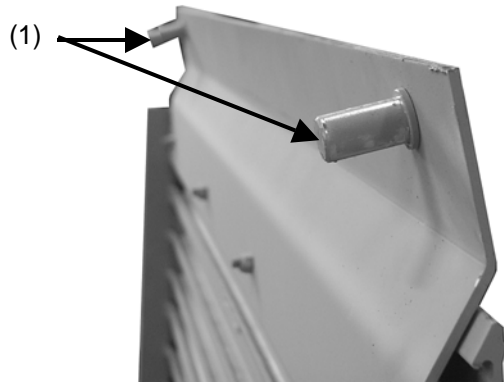

Figure 2-6. Pegs on bottom of ramp

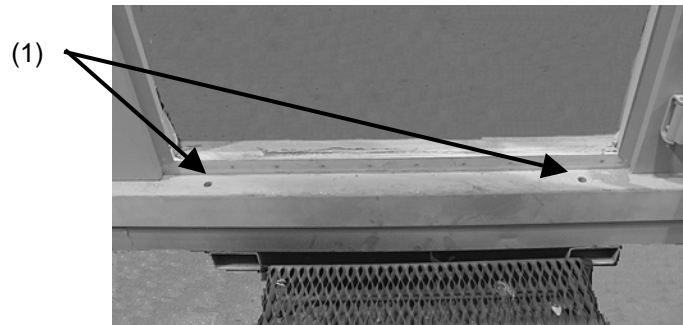

Figure 2-7. Bottom of personnel doorway.

4. Once ramp is secured to container, remove guardrail posts and strapping from box on side of ramp container.

5. Add threshold plate (2) between the end of the ramp and the door jam of the container (Fig. 2-8) when the door is open.

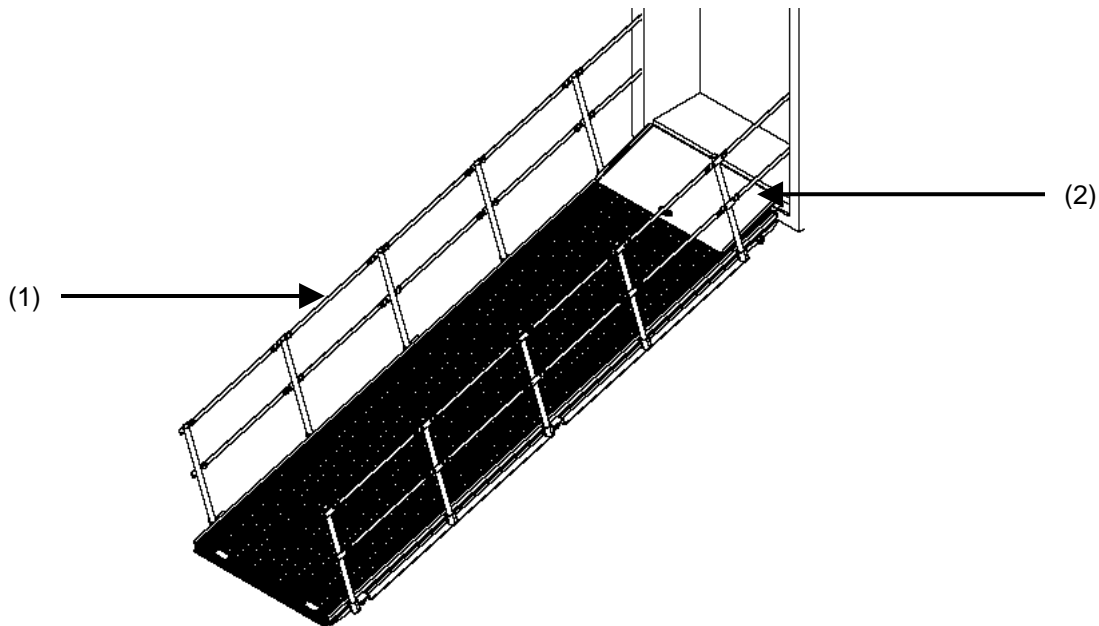

Figure 2-8. Ramp assembled.

6. Install guardrail posts in holes provided along both sides of ramp.

7. Install strapping (1) (Fig. 2-8) and tighten to desired tension.

TM 9-4910-783-13&P

INSTALLATION OF 4' X 4' RAMP

CAUTION

Ramp requires a four-person lift.

NOTE

The 4' x 4' ramp is employed when container is used on ground or flatrack.

Once container has been removed from trailer (WP 0047 00, Preparation for Movement/Shipment) and leveled (LEVELING THE CONTAINER), 4' x 4' ramp must be attached.

1. The 4' x 4' ramp (1) is stored inside container, directly in front of racks K and L. Open personnel door, unlatch ramp and remove (Fig. 2-9).
2. Attach ramp to container by placing pegs into holes provided at bottom of personnel door.
3. Add threshold plate (2) (Fig. 2-9) between the end of the ramp and the door jam of the container when the door is open.

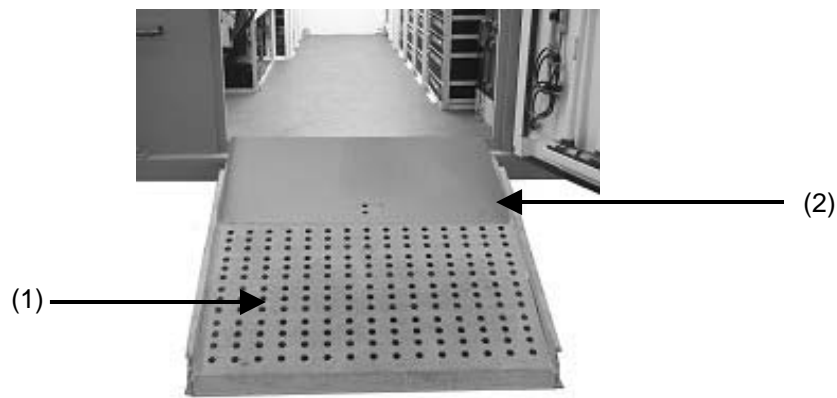

Figure 2-9. 4'x4' ramp attached

LEVELING THE CONTAINER

Once container has been placed on ground, ensure it is level. Container is equipped with two inclinometers (1) (Fig. 2-11), one to left of personnel door and one on left sidewall of container.

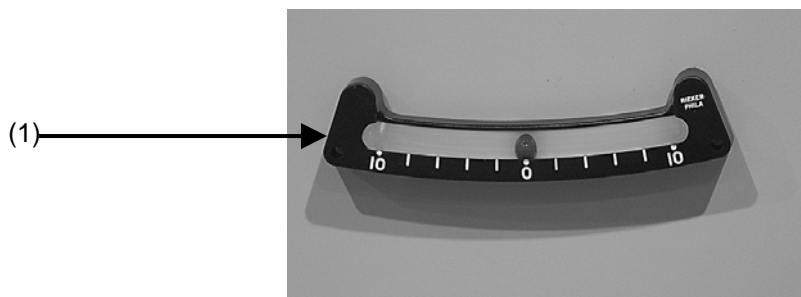

Figure 2-11. Inclinometer

TM 9-4910-783-13&P

1. If level ball is to right of inclinometer that is located next to personnel door, right side of container must be raised.

a. Obtain jack handle (1) stored on inside wall of mechanical room (Fig. 2-12).

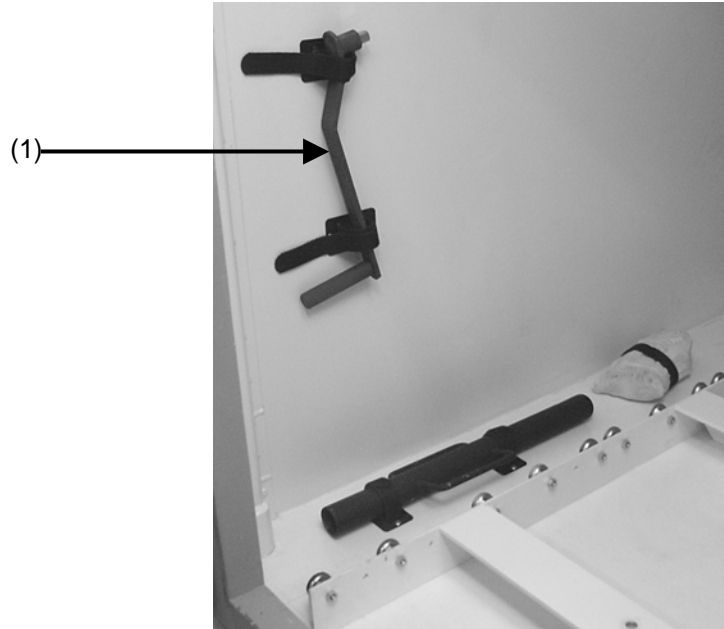

Figure 2-12. Inside view of mechanical room.

b. Go to corner of container located right of personnel door. Place jack handle (1) in jack (Fig. 2-13).

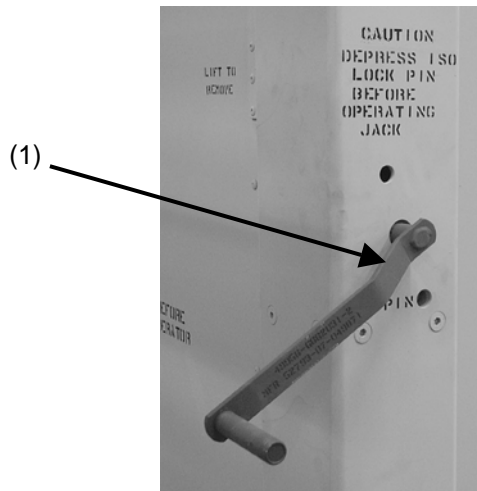

Figure 2-13. Corner post of SATS with jack handle positioned in jack

TM 9-4910-783-13&P

LEVELING THE CONTAINER (cont)

- c. Using end of 3/8" ratchet handle (WP 0058 00, SATS Base Tool Component List), depress level stop (1) (Fig. 2-14) while slowly turning jack handle clockwise one turn.

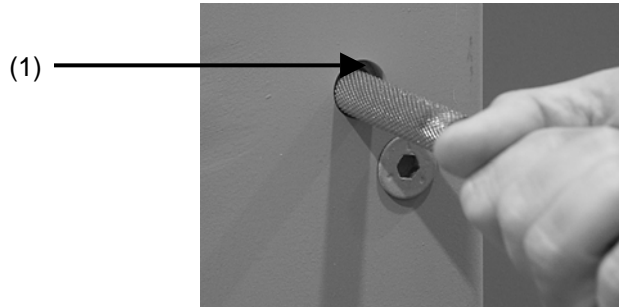

Figure 2-14. Ratchet's handle depressing level stop

- d. Remove ratchet handle and continue turning crank clockwise until jack is touching ground.
- e. Slowly turn jack handle clockwise to raise right side of container.
- f. Check inclinometer periodically to check level ball.
- g. Once ball is in center of inclinometer, container is level from left to right.
- h. Ensure jacks are in contact with ground.
2. If level ball is left of inclinometer that is located next to personnel door, left side of container must be raised.
- a. Obtain jack handle that is stored on inside wall of mechanical room.
- b. Go to corner of container located left of personnel door. Place jack handle in jack (Fig. 2-13).
- c. Using end of 3/8" ratchet handle (WP 0058 00, SATS Base Tool Component List), depress level stop (Fig. 2-14) while slowly turning jack handle clockwise one turn.
- d. Remove ratchet handle and continue turning jack handle clockwise until jack is touching ground.
- e. Slowly turn jack handle clockwise to raise left side of container.
- f. Check inclinometer periodically to check position of level ball.
- g. Once ball is in center of inclinometer, container is level from left to right.
- h. Ensure jacks are in contact with ground.
3. If unable to level using procedures in 1 and 2, proceed with 3. If level ball is right of inclinometer located on RH side of container, back end of container must be raised.
- a. Obtain jack handle stored on inside wall of mechanical room.

TM 9-4910-783-13&P

LEVELING THE CONTAINER (cont)

- b. Go to corner of container located at right side end wall. Place jack handle in jack (Fig. 2-13).
- c. Using end of 3/8" ratchet handle (WP 0058 00, SATS Base Tool Component List), depress level stop (Fig. 2-14) while slowly turning jack handle clockwise one turn.
- d. Remove ratchet handle and continue turning jack handle clockwise until jack is touching ground.
- e. Slowly turn jack handle clockwise to raise container.
- f. Check inclinometer periodically to check position of level ball.
- g. Repeat steps 2- 6 on corner of left side end wall.
- h. Once ball is in center of inclinometer, container is level from front to back.
- i. Ensure jacks are in contact with ground.

ASSEMBLY AND PREPARATION FOR USE

The SATS is fully assembled. No assembly by user is required for basic system. Once inside and outside container has been visually checked, perform following procedures:

WARNING



High voltage exists in electrical system of this equipment. Severe bodily injury or death, including death on contact, may result if personnel fail to observe safety precautions.

Confirm that container electrical system is properly grounded before connecting primary power supply or starting generator. Failure to properly ground container may result in death, severe bodily injury or damage to equipment.

CAUTION

Use of incorrect voltage, frequency or other than three-phase power may damage container electrical system or components.

1. Make sure that external power supply conforms to voltage and frequency specifications (EQUIPMENT DATA, WP 0003 00)
2. Unload tools from center aisle (See LOAD AND TIE DOWN PROCEDURE).

TM 9-4910-783-13&P

ASSEMBLY AND PREPARATION FOR USE (cont)

3. Remove T-pins from left and right side of generator. Slide generator out right side.

WARNING



Utilize single-barrier hearing protection when operating the generator.

4. Prior to powering up generator, perform generator PMCS according to TM 9-6115-642-10 and ensure all four panels (intake vent, exhaust, and both entry panels) are in open position.
5. Prior to turning on ECU, perform ECU PMCS according to TM 5-4120-386-14 and ensure ECU panel door is propped in open position.
6. Ground container (See EXTERNAL CONNECTIONS).
7. After connecting primary power supply, energize container electrical system. Check for any unusual conditions.

EXTERNAL CONNECTIONS

1. Container grounding

SATS is supplied with a grounding rod kit. It includes three sections of copper ground rod (1), two couplers, a ground rod clamp on third or top segment, and a ground rod-driving stud. Grounding rod sections are stored on side plate underneath generator toward front of mechanical room (Fig. 2-15). All three segments are identical except the third section includes a ground rod clamp at top end. To ground SATS perform the following procedures:

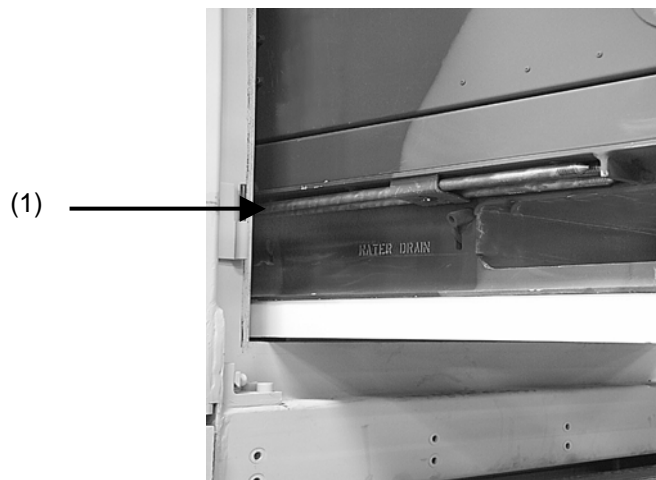

Figure 2-15. Grounding rod stored at bottom of generator.

EXTERNAL CONNECTIONS (cont)

- a. Install ground rod driving nut in end of first rod segment.
- b. Using slide hammer (1) (located in mechanical room beneath jack handle) (Fig. 2-16), drive first segment into ground near container ground stud assembly.

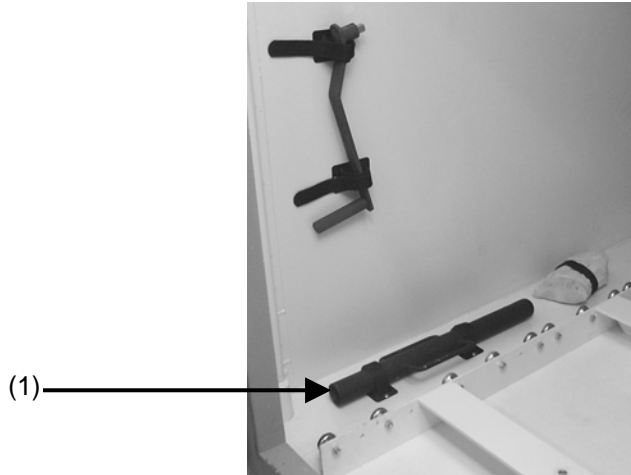

Figure 2-16. Mechanical room

- c. When top of segment is about six inches (152 mm) above ground, remove ground rod driving nut and thread it into second rod segment. Place one of the couplers on end of first segment. Thread end of second segment into top of coupler on first segment.
- d. Continue driving rod into ground until top of second segment is within six inches (152 mm) of ground.
- e. Place second coupler on end of second segment and thread ground rod-driving nut into end of third segment.
- f. Install third or top segment (with ground rod clamp) on top of second segment and continue driving assembly until 6 to 12 inches (152 to 304 mm) of third segment are showing above ground surface.

TM 9-4910-783-13&P

STANDARD AUTOMOTIVE TOOL SET (SATS)

0005 00

EXTERNAL CONNECTIONS (cont)

g. Connect grounding rod to GND terminal (1) of 120/208 VAC, 3-Phase, 60 Hz power input panel (Fig 2-17). Clamp one end of ground wire to wire clamp on rod and other end under wing nut of ground post.

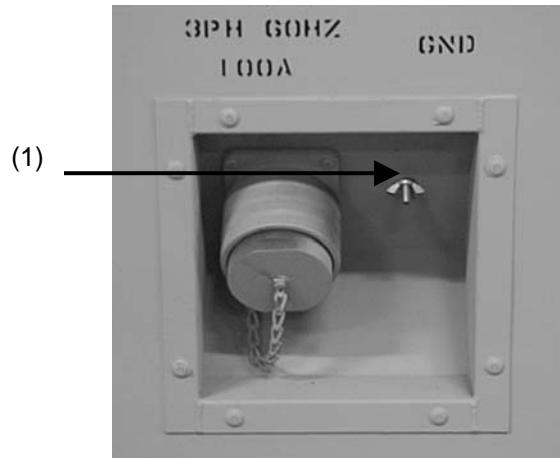

Figure 2-17. Power Input Receptacle

2. Input power connection

WARNING



Do not attempt connection of live line to power entry panel. Deactivate power source or generator before procedure.

Confirm that container electrical system is properly grounded before connecting the primary power supply. Failure to properly ground container may result in death, severe bodily injury, or damage to equipment.

CAUTION

Power supply shall be 120/208 VAC, 3-Phase, 60 Hz 4 wires with 4 grounds or damage to equipment will result.

CAUTION

Use of incorrect voltage, frequency or power other than three phase may damage the container electrical system or components.

TM 9-4910-783-13&P

EXTERNAL CONNECTIONS (cont)

- a. Turn all circuit breakers to OFF position.

NOTE

Make certain that Power Input Receptacle and power supply cables are terminated with same type of connector.

- b. Connect cable assembly (from Generator or external power source) to container INPUT plug inlet connector (1) (Fig. 2-18) of 120/208 VAC, 3 phase, 60 Hz power input panel and turn locking collar clockwise until connection is secure.

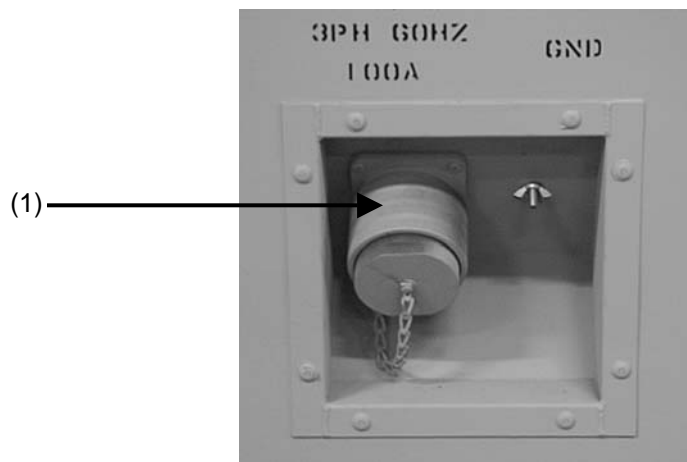

Figure 2-18. Power Input Receptacle

- c. Start Generator in accordance with TM 9-6115-642-10.
- d. Connect ECU supply cable to receptacle located on ECU.
- e. Turn MAIN circuit breaker to ON position and observe any unusual conditions.
- f. Turn remaining circuit breakers to ON position one at a time and observe any unusual conditions.

TM 9-4910-783-13&P

LOAD AND TIE DOWN PROCEDURE

Load and tie down procedures for the SATS are as follows. Prior to movement, all tools and equipment associated with this set must be securely locked or tied down in the appropriate place. For most items there are drawers or racks with positions identified and appropriate locking devices provided.

There are, however, six items that require further information (as follows) on how and where they are to be transported. These items are listed below:

- Air Compressor – Base Tool set
- Workbenches - BII
- Transmission Jack # 1 – FMM1
- Transmission Jack # 2 – FMM2
- Wheel Lift - Base Tool Set
- 4' Door Ramp - BII

To facilitate standardization for both, rapid set up and packing of SATS, the system is provided with floor and wall mounted numbered D Rings (see Fig. 2-19) and various sized ratchet straps.

BASE, FMM1, AND FMM2 CONFIGURATION

Unloading Required Items for Operation:

1. Remove tie-down straps from D15 to D18 and tie-down strap D14 to D19, then off-load wheel lift.
2. Remove tie-down straps D20, D21, D22, and D23 from holes in ramp, then off-load ramp.
3. Remove tie-down D11 to D17 and tie-down D12 to D14 and tie-down D13 to D16. Off-load transmission jack accessory box then off-load transmission jack.
4. Remove tie-down D8 to D11, tie-down D6 to D13, and D9 to D10. Off-load transmission jack accessory box then off-load transmission jack.
5. Remove tie-down D4 to D7, D3 to D8, and D5 to D6, and off-load workbenches.
6. Remove tie-down D1 to D3 and D2 to D5 and off-load air compressor.

Loading for Movement and Transportation from Operational Configuration.

1. Load air compressor wheels forward. Secure tie-down D1 to D3 and D2 to D5.
2. Load work benches (both benches must be secured together). Secure tie-down D4 over bench to D7, D3 through legs to D8, and D5 through legs to D6.
3. Load first transmission jack with narrow end forward. Jack should be parallel to aisle. Load jack accessory box onto jack. Place first strap from tie-down D8 through left rear jack handle over jack accessory box through right rear handle to tie-down D6. Do not tighten this strap at this time. Ensuring that ratcheting mechanisms are on the same side of the jack, place second strap from tie-down D13 through left front jack handle over jack accessory box through right front jack handle to tie-down D11. If jack accessory box position prevents placing this strap over jack accessory box, place over jack only. Tighten the two straps simultaneously to ensure jack maintains alignment and placement on floor of container. Place third strap from tie-down D10 over jack accessory box to tie-down D9 and tighten.

TM 9-4910-783-13&P

LOAD AND TIE DOWN PROCEDURE (cont)

4. Load second transmission jack with wide end forward. Jack should be parallel to aisle. Load jack accessory box onto jack. Place first strap from tie-down D13 through left rear jack handle over jack accessory box through right rear handle to tie-down D11. If jack accessory box position prevents placing this strap over jack accessory box, place over jack only. Do not tighten this strap at this time. Ensuring that ratcheting mechanisms are on the same side of the jack, place second strap from tie-down D17 through left front jack handle over jack accessory box through right front jack handle to tie-down D16. Tighten the two straps simultaneously to ensure jack maintains alignment and placement on floor of container. Place third strap from tie-down D15 over jack accessory box to tie-down D14 and tighten.

5. Load ramp between tool rack and D16, D14 and D11 tie-down rings, mountings pegs under lip of trestle hoist rack. This is in front of tool racks L & K. Tie down D20 over left edge of ramp to drain hole on far side of ramp, D21 over top of hoists to hole on lower half of ramp. Repeat for D22 and D23.

6. Load wheel lift with lift arms forward. The narrow end of the second transmission jack should be between the horizontal wheel lift arms. Place first strap from tie-down D15 around lift upright to tie-down D14. Do not tighten at this time. Ensuring that ratcheting mechanisms are on the same side of the lift, place second strap from tie-down D19 around lift upright to tie-down D18. Both straps should be at the base of the lift upright where it is attached to the horizontal lifting arms. Tighten straps simultaneously to ensure lift maintains alignment and placement on floor of container. Place third strap from tie-down D17 over the horizontal lifting arms to tie-down D16 and tighten.

BASE AND FMM1 CONFIGURATION

Unloading Required Items for Operation:

1. Remove tie-down straps from D15 to D18 and tie-down strap D14 to D19, then off-load wheel lift.
2. Remove tie-down straps D20, D21, D22, and D23 from holes in ramp, then off-load ramp.
3. Remove tie-down D8 to D11, tie-down D6 to D13, and D9 to D10. Off-load transmission jack accessory box then off-load transmission jack.
4. Remove tie-down D4 to D7, D3 to D8, and D5 to D6, and off-load workbenches.
5. Remove tie-down D1 to D3 and D2 to D5 and off-load air compressor

Loading for Movement and Transportation from Operational Configuration.

1. Load air compressor wheels forward. Secure tie-down D1 to D3 and D2 to D5.
2. Load workbenches (both benches must be secured together). Secure tie-down D4 over bench to D7, D3 through legs to D8, and D5 through legs to D6.
3. Load transmission jack with narrow end forward. Jack should be parallel to aisle. Load jack accessory box onto jack. Place first strap from tie-down D8 through left rear jack handle over jack accessory box through right rear handle to tie-down D6. Do not tighten this strap at this time. Ensuring that ratcheting mechanisms are on the same side of the jack, place second strap from tie-down D13 through left front jack handle over jack accessory box through right front jack handle to tie-down D11. If jack accessory box position prevents placing this strap over jack accessory box, place over jack only. Tighten the two straps simultaneously to ensure jack maintains alignment and placement on floor of container. Place third strap from tie-down D10 over jack accessory box to tie-down D9 and tighten.

TM 9-4910-783-13&P

LOAD AND TIE DOWN PROCEDURE (cont)

4. Load ramp between tool rack and D16, D14 and D11 tie-down rings, mountings pegs under lip of trestle hoist rack. This is in front of tool racks L & K. Tie down D20 over left edge of ramp to drain hole on far side of ramp, D21 over top of hoists to hole on lower half of ramp. Repeat for D22 and D23.
5. Load wheel lift with lift arms forward. The narrow end of the second transmission jack should be between the horizontal wheel lift arms. Place first strap from tie-down D15 around lift upright to tie-down D14. Do not tighten at this time. Ensuring that ratcheting mechanisms are on the same side of the lift, place second strap from tie-down D19 around lift upright to tie-down D18. Both straps should be at the base of the lift upright where it is attached to the horizontal lifting arms. Tighten straps simultaneously to ensure lift maintains alignment and placement on floor of container. Place third strap from tie-down D17 over the horizontal lifting arms to tie-down D16 and tighten.

BASE CONFIGURATION

Unloading Required Items for Operation:

1. Remove tie-down straps from D15 to D18 and tie-down strap D14 to D19, then off-load wheel lift.
2. Remove tie-down straps D20, D21, D22, and D23 from holes in ramp, then off-load ramp.
3. Remove tie-down D4 to D7, D3 to D8, and D5 to D6, and off-load workbenches.
4. Remove tie-down D1 to D3 and D2 to D5 and off-load air compressor

Loading for Movement and Transportation from Operational Configuration.

1. Load air compressor wheels forward. Secure tie-down D1 to D3 and D2 to D5.
2. Load workbenches (both benches must be secured together). Secure tie-down D4 over bench to D7, D3 through legs to D8, and D5 through legs to D6.
3. Strap threshold plate to 4 x 4 ramp. Load ramp between tool rack and D16, D14 and D11 tie-down rings, mountings pegs under lip of trestle hoist rack. This is in front of tool racks L & K. Tie down D20 over left edge of ramp to drain hole on far side of ramp, D21 over top of hoists to hole on lower half of ramp. Repeat for D22 and D23.
4. Load wheel lift with lift arms forward. The narrow end of the second transmission jack should be between the horizontal wheel lift arms. Place first strap from tie-down D15 around lift upright to tie-down D14. Do not tighten at this time. Ensuring that ratcheting mechanisms are on the same side of the lift, place second strap from tie-down D19 around lift upright to tie-down D18. Both straps should be at the base of the lift upright where it is attached to the horizontal lifting arms. Tighten straps simultaneously to ensure lift maintains alignment and placement on floor of container. Place third strap from tie-down D17 over the horizontal lifting arms to tie-down D16 and tighten.

TM 9-4910-783-13&P

LOAD AND TIE DOWN PROCEDURE (cont)

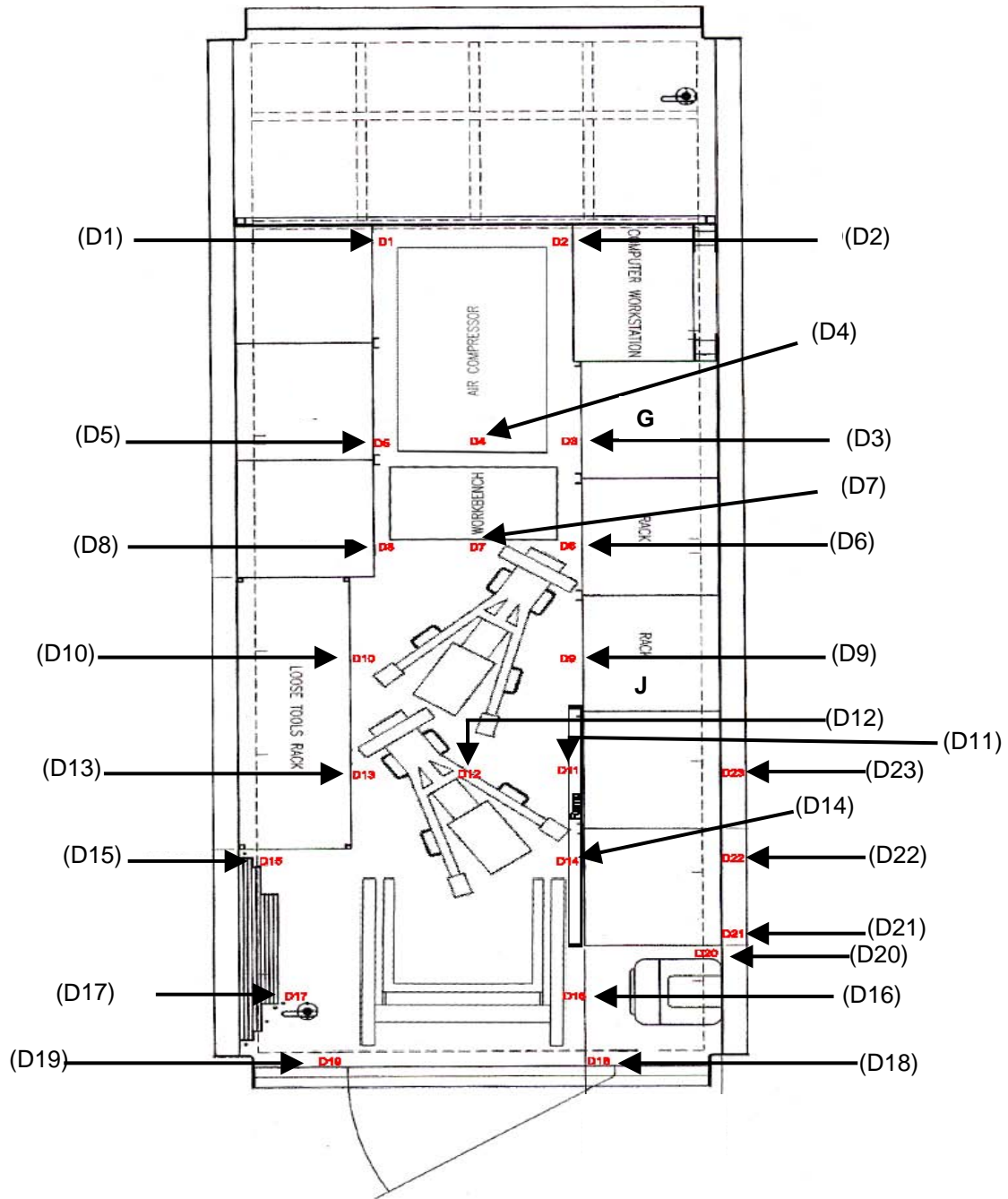

Figure 2-19. Layout of D rings in SATS.

TM 9-4910-783-13&P

AREA LIGHT INSTALLATION

There are two area lights for the SATS. They can be placed on ground using tripod legs. They are both stored on inside of personnel door.

1. Remove area lights (1) from storage location inside container on inside of personnel door (Fig. 2-20).

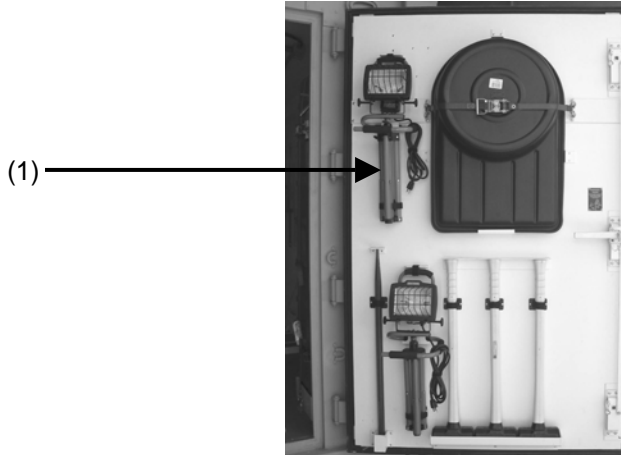

Figure 2-20. View of inside of personnel door.

2. Place area lights on ground by extending tripod legs (Fig. 2-21).



Figure 2-21. Area lights on extended tripod legs.

3. Connect cables into container exterior receptacles.

TM 9-4910-783-13&P

STANDARD AUTOMOTIVE TOOL SET (SATS)

0005 00

POWER SHUTDOWN

CAUTION

Once power is off, no light source will be available. Ensure you have an alternate source of light to maneuver around loose tools.

1. On CB panel, set each CB to OFF position ending with Main CB.
2. Confirm that supply cable is de-energized at its source (generator or shore power have been turned off).

WARNING



Do not attempt to disconnect a live supply cable from container.

3. Disconnect deactivated supply cable by turning connector retaining nut counterclockwise and pulling connector away from container wall.

OPERATING INSTRUCTIONS

Due to limited operating capability of container, operating instructions are limited to operation of circuit breakers and switches for purpose of providing power to lights, outlets, and environmental control unit (ECU). Closing container includes maintaining container when performing any Preventive Maintenance Checks and Services (PMCS) exercise "During" functions.

TM 9-4910-783-13&P

STANDARD AUTOMOTIVE TOOL SET (SATS)

0005 00

DECALS (STENCILS) AND INSTRUCTION PLATES

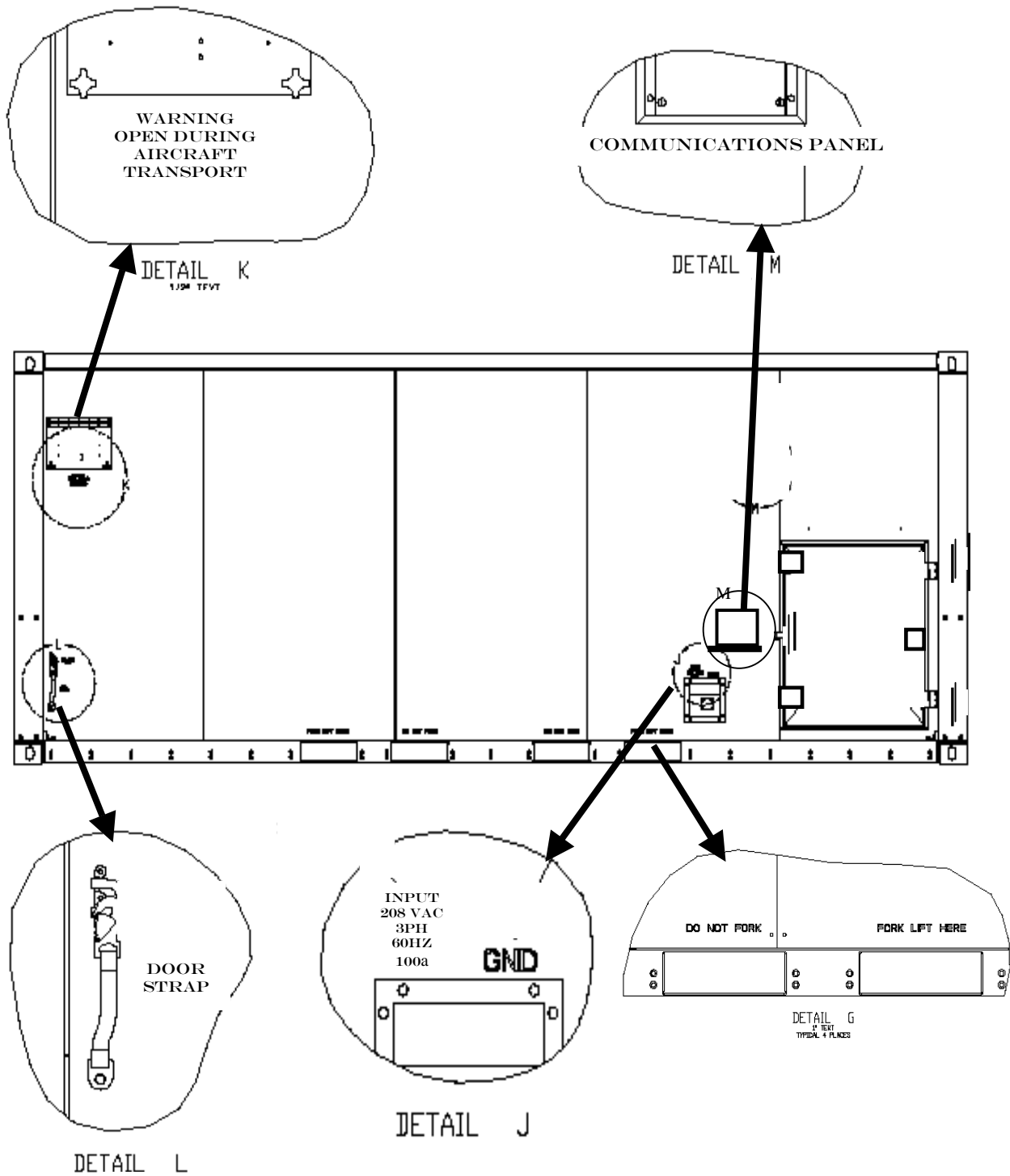

Figure 2-22. RH sidewall stencils.

TM 9-4910-783-13&P

DECALS (STENCILS) AND INSTRUCTION PLATES (cont)

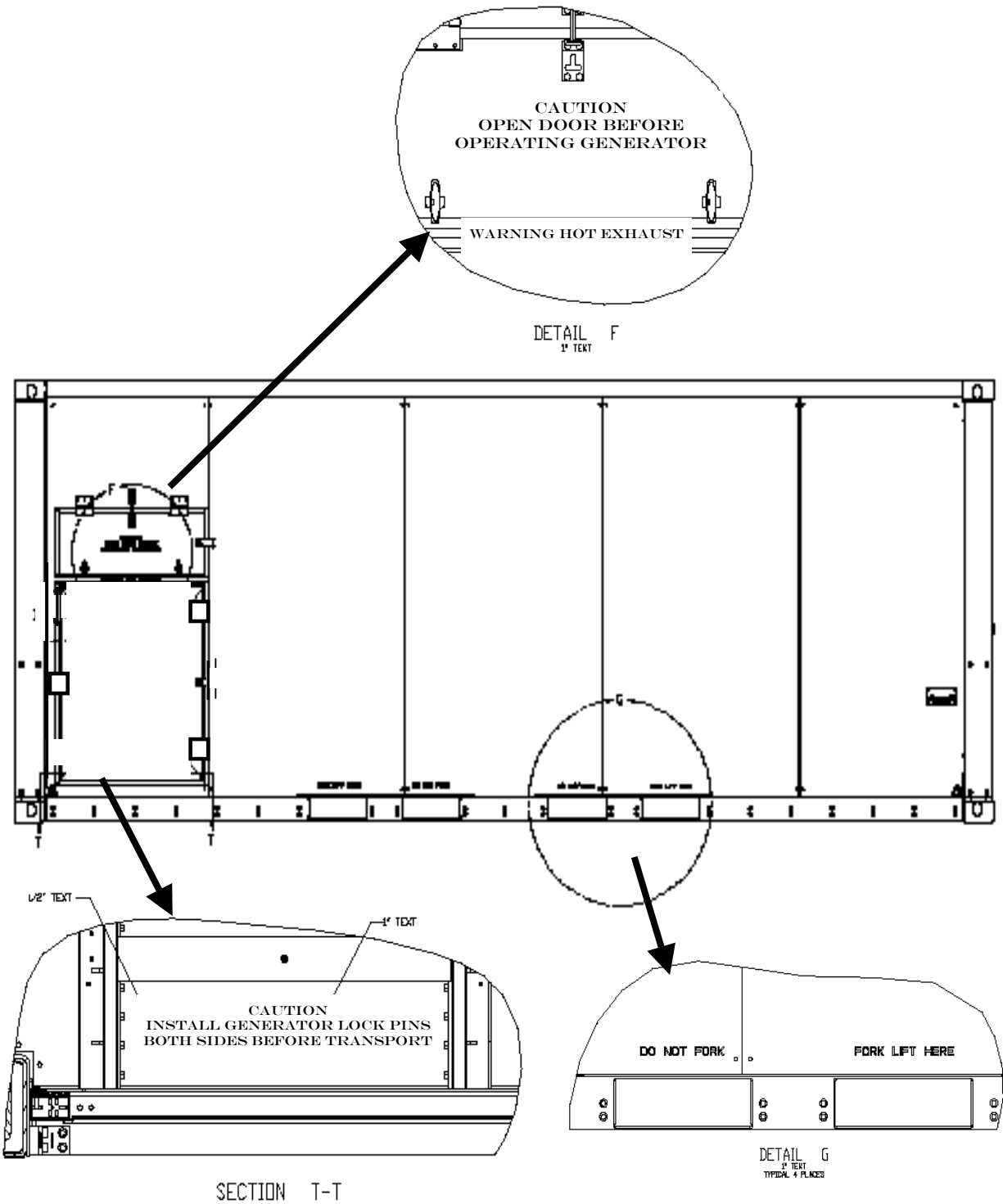

Figure 2-23. LH sidewall stencils.

TM 9-4910-783-13&P

STANDARD AUTOMOTIVE TOOL SET (SATS)

0005 00

DECALS (STENCILS) AND INSTRUCTION PLATES (cont)

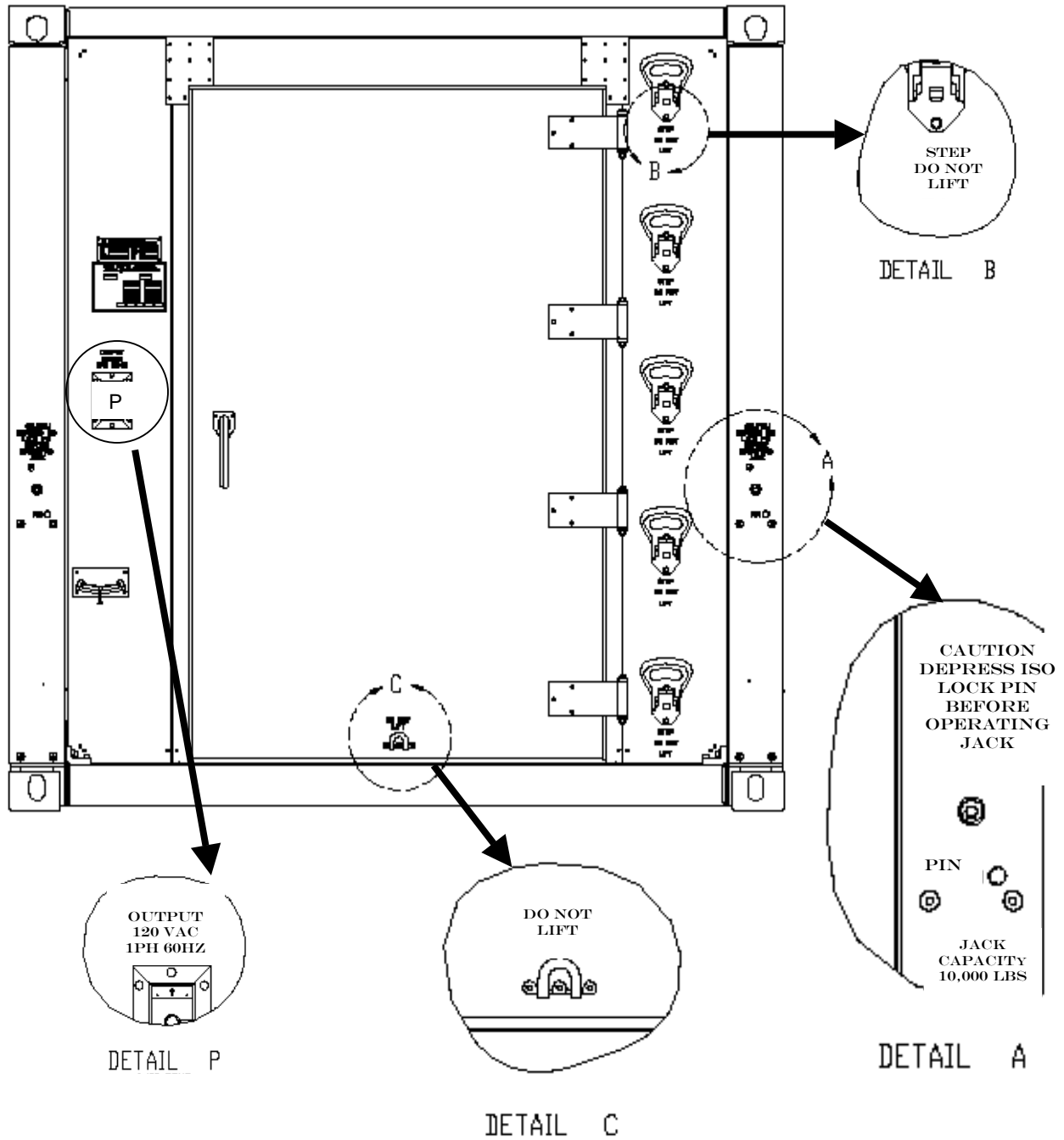

Figure 2-24. Personnel end wall stencils.

TM 9-4910-783-13&P

STANDARD AUTOMOTIVE TOOL SET (SATS)

0005 00

DECALS (STENCILS) AND INSTRUCTION PLATES (cont)

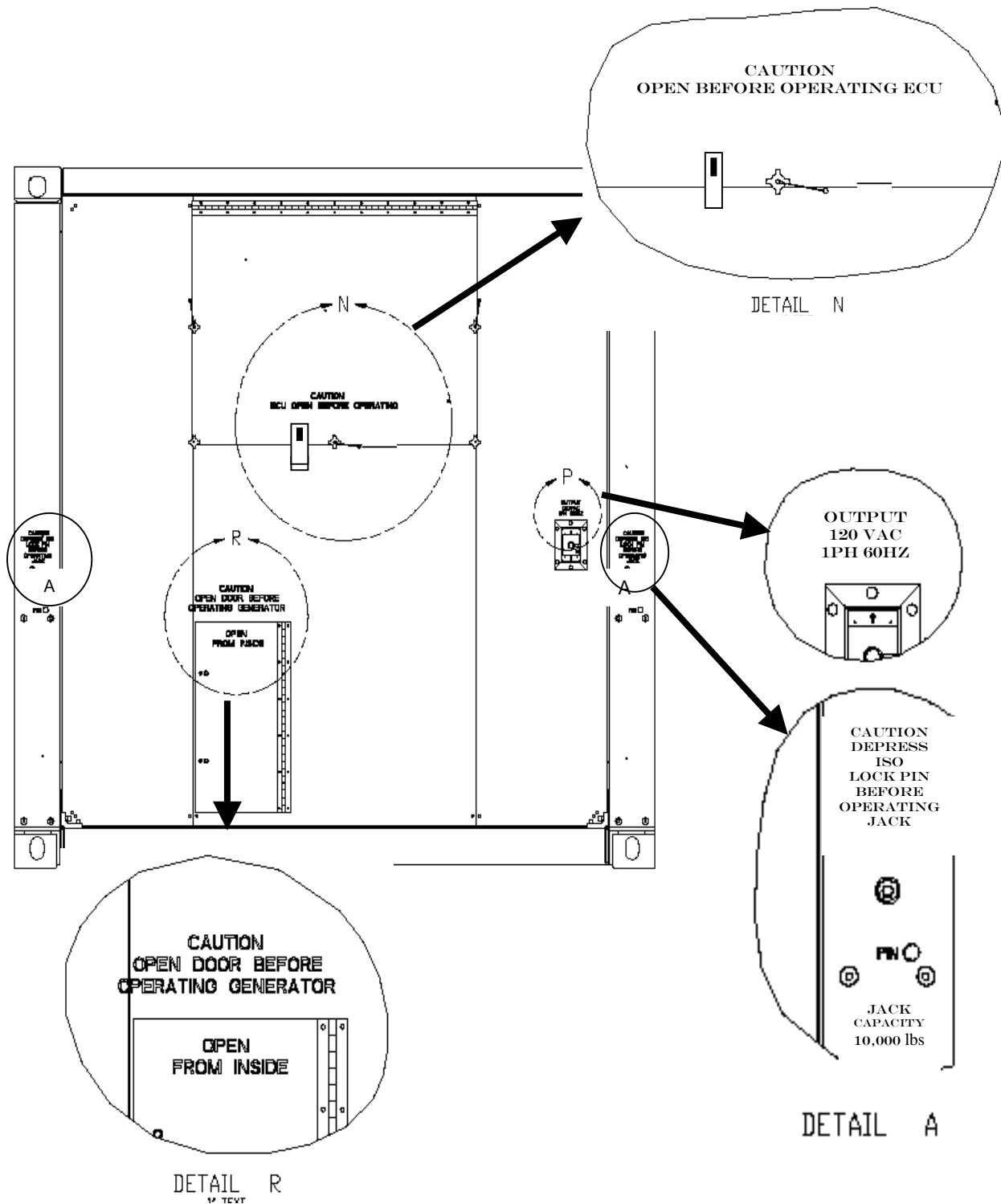

Figure 2-25. Cargo end wall stencils.

END OF WORK PACKAGE

TM 9-4910-783-13&P

STANDARD AUTOMOTIVE TOOL SET (SATS)

0006 00

OPERATION UNDER UNUSUAL CONDITIONS

GENERAL

This section provides instructions for operation of container in unusual weather conditions. Operation during blackout conditions is also provided.

SECURITY MEASURES FOR ELECTRONIC DATA

The computer cabinet provided is lockable.

OPERATION IN RAIN AND/OR MUD

1. Provide adequate drainage ditch to prevent standing water around container area.
2. Check seals for proper placement and compression.

OPERATION IN SNOW, ICE, OR EXTREME COLD

WARNING

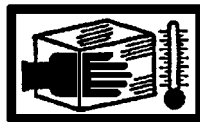

In extreme cold, do not touch metal parts with bare hands.
Severe skin damage may result.

1. Remove snow routinely with a soft bristle brush, broom, or equivalent. Roof access can be obtained by use of folding steps located on personnel end wall.
2. Insure ECU is properly connected to container (WP 0005 00, EXTERNAL CONNECTIONS).
3. Keep door closed.

NOTE

Fluorescent lights have a delay time in coming on at temperatures of 0°F and below.

OPERATION DURING BLACKOUT CONDITIONS

NOTE

During blackout condition, enter and leave container through personnel door only. Do not operate exterior area light.

1. Activate all interior lights and check from 25 feet (7.6 meters) away to ensure no light is visible.

TM 9-4910-783-13&P

OPERATION DURING BLACKOUT CONDITIONS (cont)

2. Place blackout override switch (1) to OFF position (Fig. 2-23).

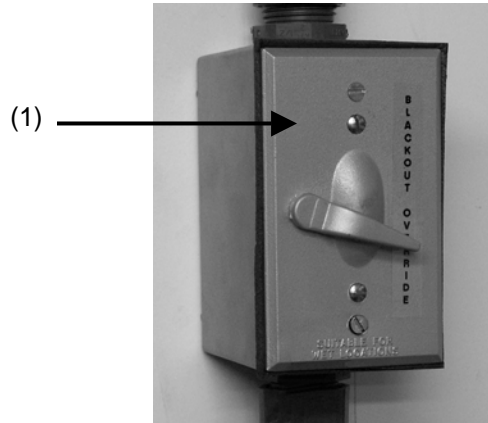

Figure 2-23. Blackout override switch.

NOTE

Blackout override switch must remain in OFF position for duration.

EMERGENCY POWER SHUTDOWN

1. Set Main CB to OFF.
2. Disconnect primary power supply. Confirm that supply cable is de-energized at its source (generator or shore power have been turned off).

WARNING



DO NOT ATTEMPT TO DISCONNECT A LIVE SUPPLY CABLE FROM CONTAINER.

3. Remove ground rod from ground, disassemble sections and store components on side plate underneath generator toward front of mechanical room.

END OF WORK PACKAGE

TM 9-4910-783-13&P

STANDARD AUTOMOTIVE TOOL SET (SATS)

0007 00

ON-VEHICLE EQUIPMENT LOADING PLAN

GENERAL

The container may be lifted using a crane, hoist, or a forklift. Perform following instructions when using any acceptable means of lifting container.

CAUTION

If container is punctured during loading or securing, repair puncture as soon as possible to prevent moisture from seeping into panels or damage to container may occur. Refer to WP 0041 00 for general maintenance procedure.

MOVING CONTAINER WITH A FORKLIFT

When moving container with a forklift, personnel should comply with the following:

Observe general precautions and instructions outlined in WP 0047 00, Preparation for Shipment and Storage.

WARNING

Failure to ensure that forklift is capable of handling full weight of container and contents may result in damage to container. Improper lifting could result in container unit sliding off tines causing personal injury or death.

WARNING

Failure to ensure forklift tine's entrance into tubes may result in damage to the container unit. Improper lifting could result in the container unit sliding off tines causing personal injury or death.

Use a ground guide to ensure that forklift tines enter forklift tubes (1) in container base. (Labeled FORKLIFT HERE – Fig. 2-24)

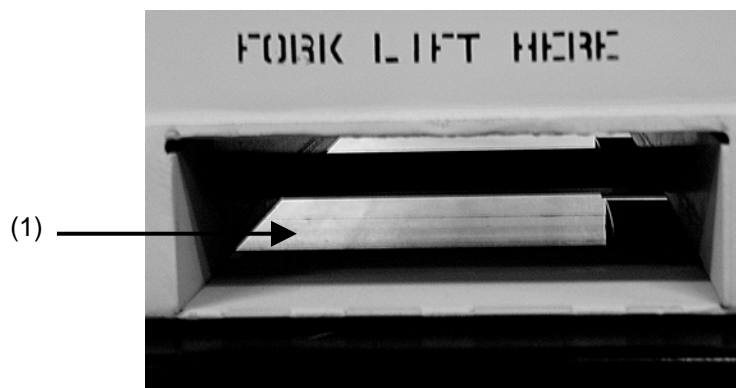

Figure 2-24. Forklift tubes in container base.

TM 9-4910-783-13&P

MOVING CONTAINER WITH A CRANE OR HOIST

NOTE

Reference following documents prior to lifting container by external air transport or overhead lift by crane:

(1) MIL-STD-209J – Interface Standard for Lifting and Tiedown Provisions

(2) MIL-STD-913A – Requirements for the Certification of Sling Loaded Military Equipment for External Transportation by Department of Defense Helicopters

Container may be lifted or moved with an overhead crane using an external sling. Folding steps (1) on container may be lowered to allow personnel to climb on top of unit (Fig. 2-25). Folding steps must be returned to upright position prior to container being moved. This allows easier access to ISO corners for attachment purposes. Hoisting from ISO corners should be performed as follows:

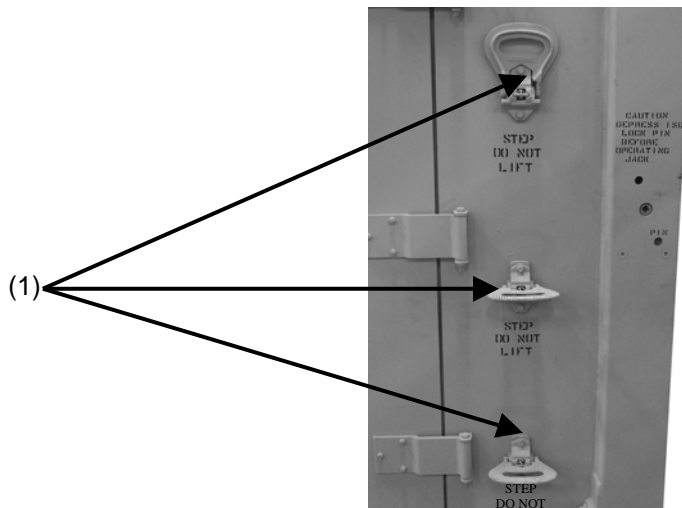

Figure 2-25. Folding steps located on personnel end wall.

1. Observe general precautions and instructions outlined in WP 0047 00, Preparation for Shipment and Storage.

WARNING

Failure to ensure that hoisting sling is capable of handling full weight of container and contents may result in damage to container. Improper placement of sling onto container could result in container unit sliding out of sling, causing personal injury or death.

CAUTION

Do not attach hoisting sling to handling equipment in such a manner that angle between any hoist line and SATS is less than 45 degrees (per Mil-Std-209J and Mil-Std-913A). Any angle less than 45 degrees will cause excessive strain, which could damage container.

TM 9-4910-783-13&P

MOVING CONTAINER WITH A CRANE OR HOIST (cont)

2. Ensure that hoisting sling is capable of supporting full weight of the SATS. Then attach sling to crane (or equivalent) and to four ISO corners located at upper four corners of container.
3. Hoist container and position to desired location.

MOVING CONTAINER IN TRANSPORT AIRCRAFT

The container has provisions for being transported in Transport Aircraft. To air ship SATS, observe general precautions and instructions outlined in WP 0047 00, Preparation for Shipment and Storage. Six detent rails are provided with container to be used in air transport.

CAUTION

Decompression panel must be opened prior to flight to avoid damage to container.

REMOVING DETENT RAILS FROM STORAGE

Six detent rails (1) (3 thin and 3 wide) are stored in mechanical compartment above generator (Fig. 2-26).

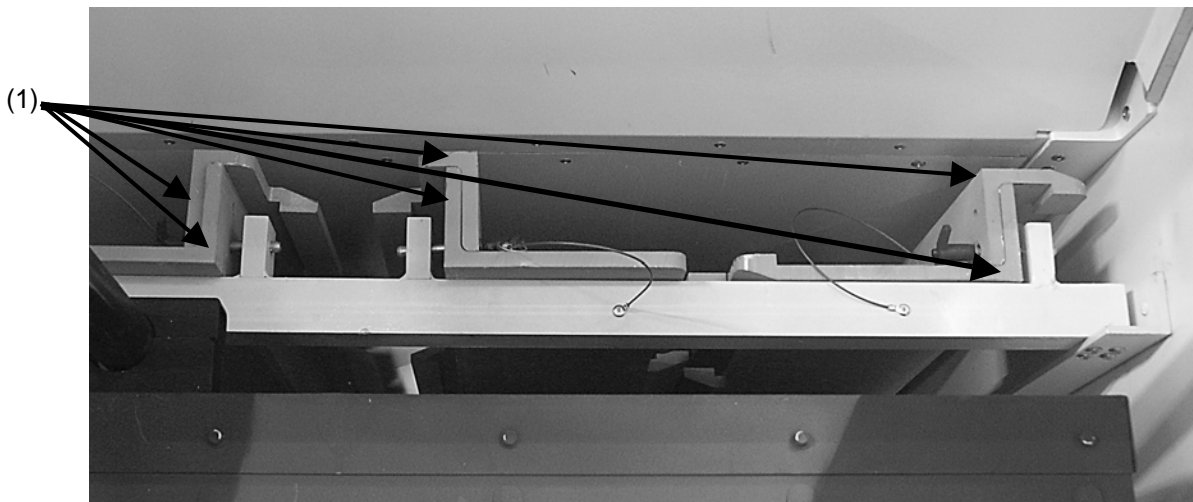

Figure 2-26. Detent rails stored.

TM 9-4910-783-13&P

REMOVING DETENT RAILS FROM STORAGE (cont)

1. Remove three T-pins (1) (Fig. 2-27) on each side of mechanical compartment by pushing end of pin in and pulling it straight out.

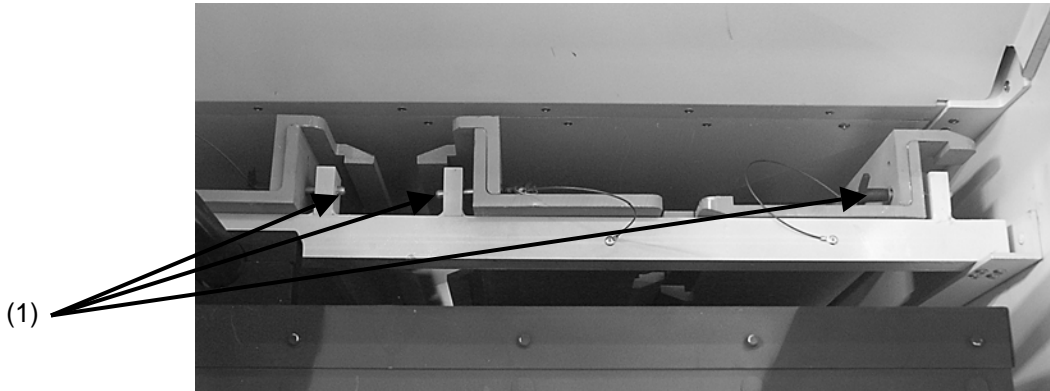

Figure 2-27. T-pins for detent rails.

NOTE

Prior to removing detent rails from container, open auxiliary generator access panel.

2. Open auxiliary generator panel.
3. Pull six detent rails straight out.
4. Once detent rails have been removed, place T-pins back into holes provided.

INSTALLING DETENT RAILS ON CONTAINER

1. Retrieve bag of 3/8" detent rail bolts and lock washers (1) from inside mechanical room of container (Fig. 2-28). There should be a total of 84 bolts in bag.

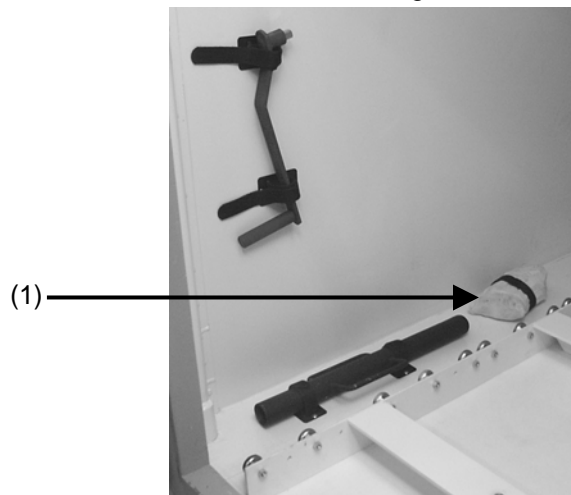

Figure 2-28. Mechanical room in container.

TM 9-4910-783-13&P

INSTALLING DETENT RAILS ON CONTAINER (cont)

2. There are three wide rails and three thin rails. Ensure all three wide rails (1) (b) are bolted to side that will be in center of aircraft and three thin rails (2) (a) are bolted to other side (Fig. 2-29).



Figure 2-29. Detent rails installed on container.

3. The notched wide and notched thin rails should be bolted to center of container.

CAUTION

If bolts spin and do not tighten, or they become stripped, advise Load Master. Additional tie downs for container may be needed.

CAUTION

Do not over tighten bolts. Tighten to snug.

4. Using appropriate tool, bolt detent rails to sides of container using provided holes (1) (Fig. 2-30).

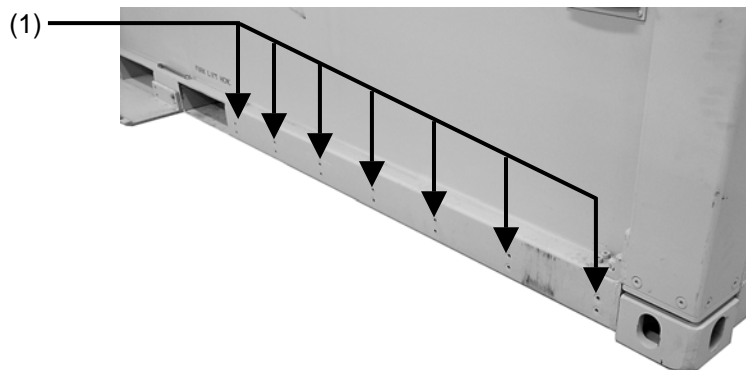

Figure 2-30. Detent rail installation points.

TM 9-4910-783-13&P

REMOVING DETENT RAILS FROM CONTAINER

1. Using 9/16" wrench (WP 0058 00, SATS Base Tool Component List), remove 42 bolts and lock washers that attach detent rails to each side of container.
2. Place bolts in bag provided and store bag inside mechanical room of container beneath jack handle.

STORING THE DETENT RAILS

1. Pair narrow rails and wide rails together so that you have three sets each of narrow and wide rails.
2. Nest narrow rail (1) inside wide rail (2) in all three sets (Fig. 2-31).

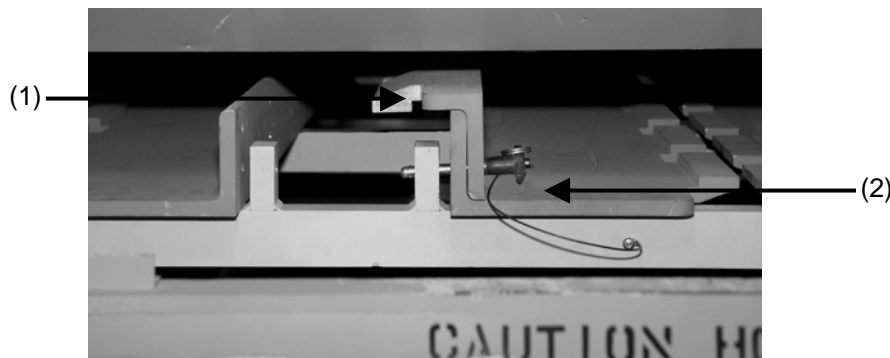

Figure 2-31. Detent rails nested and stored.

3. Remove six T-pins from holes in storage compartment (there are three on each end).
4. Slide nested rails into space above generator (1) as shown in Figure 2-32.



Figure 2-32. Nested detent rails stored above generator.

5. Once rails are in place, insert three T-pins on each end to secure.

END OF WORK PACKAGE

TM 9-4910-783-13&P

CHAPTER 3
TROUBLESHOOTING PROCEDURES
FOR
STANDARD AUTOMOTIVE TOOL SET (SATS)

FIELD (OPERATOR) TROUBLESHOOTING PROCEDURES

GENERAL

This section contains operator troubleshooting information for locating and correcting common malfunctions that may develop in container.

WARNING



HIGH VOLTAGE exists in electrical system of this equipment
DEATH ON CONTACT may result if personnel fail to observe
safety precautions.

1. WP 0008 00 lists common malfunctions that you may find during operation or maintenance of container electrical system or components. You should perform inspections and corrective actions in order listed.
2. All malfunctions that may occur and all inspections and corrective actions may not be listed. If a malfunction is not listed, or is not corrected by corrective action, notify your supervisor.
3. When troubleshooting operation of container electrical system, all switches and circuit breakers shall be placed in OFF positions with power connected.
4. The operator is limited to setting circuit breakers (ON/OFF), setting light assemblies in place, and replacing light bulbs.

OPERATOR TROUBLESHOOTING

MALFUNCTION

TEST OR INSPECTION

CORRECTIVE ACTION

1. NO POWER DISTRIBUTION TO CONTAINER.

Step 1. Check that outside power is properly connected to service entrance connector on Power Input Receptacle, and check general condition of cable and connectors. If on board 10KW generator is used, make sure generator main circuit breaker (CB) is closed.

- a. Make proper power connection (WP 0026 00).
- b. Check for defective cable or connectors.

TM 9-4910-783-13&P

OPERATOR TROUBLESHOOTING (cont)

Step 2. Check and reset main circuit breaker and check outside power.

Notify Field (unit) Maintenance.

2. BLACKOUT LIGHT FAILS TO COME ON.

Step 1. Check and reset CB21 and CB2.

Step 2. Check visually for burned out blackout bulb.

Change bulb (WP 0031 00, Removal).

Step 3. Check operation of blackout light switch and blackout override switch.

- a. Check light switch is in ON position.
- b. Check blackout override switch is in blackout position.
- c. Check blackout switch is open (door is open).
- d. Notify Field (unit) Maintenance.

WARNING

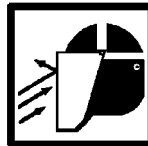

In event of lamp breakage, care must be taken in removal of broken glass fragments and dust that may be dispersed within fixture. Inhalation of dust could cause serious injury. Ensure area is well ventilated.

Cleanup requires special care due to mercury droplet proliferation. Contact your supervisor for disposal guidance.

3. ALL ROOF AREA CEILING LIGHTS (FLUORESCENTS) FAIL TO COME ON.

Step 1. Check operation of fluorescent light switch in ON position.

Step 2. If blackout override switch is in blackout position, ensure blackout switch is closed (in Override position).

Step 3. Check and reset CB2.

Step 4. Notify Field (Unit) Maintenance.

TM 9-4910-783-13&P

OPERATOR TROUBLESHOOTING (cont)

4. ONE OR MORE ROOF AREA CEILING LIGHTS FAIL TO COME ON.

Step 1. Check visually for burned out fluorescent lamps.

Step 2. Turn off CB2 and replace lamp. (WP 0014 00, Ceiling Light)

Step 3. Turn on CB2.

Step 4. Notify Field (Unit) Maintenance.

5. NO POWER AT ONE OR MORE INTERIOR UTILITY OUTLETS.

Step 1. Check and reset associated circuit breakers (CB4 and CB6).

Step 2. Notify Field (Unit) Maintenance.

6. NO POWER AT ONE OR BOTH EXTERIOR UTILITY OUTLETS.

Step 1. Check ground fault button has not been tripped.

Step 2. Check and reset CB8.

Step 3. Notify Field (Unit) Maintenance.

7. AREA LIGHT FAILS TO COME ON.

Step 1. Check visually for burned out bulb.

Step 2. Check light is correctly connected to receptacle.

Step 3. Check and reset CB8.

a. Change bulb.

b. Replace light assembly.

8. NO POWER AT ECU.

Step 1. Check outside power is properly connected to service entrance connector on Power Input Receptacle, and check general condition of cable and connectors.

a. Make proper power connection.

b. Check for defective cable or connectors.

Step 2. Check and reset CB3.

Step 3. Refer to ECU TM 5-4120-386-14 pg. 3-1 for additional troubleshooting procedures.

Step 4. Notify Field (Unit) Maintenance.

END OF WORK PACKAGE

TM 9-4910-783-13&P

FIELD (UNIT) TROUBLESHOOTING PROCEDURES

GENERAL

This section contains field level troubleshooting information for locating and correcting common malfunctions that may develop in container electrical system.

TROUBLESHOOTING

Each malfunction for an individual component or unit is listed within the FIELD (UNIT) TROUBLESHOOTING PROCEDURES. The malfunction is followed by a list of tests or inspections that help to determine probable causes and corrective actions to take. The tests or inspections and corrective actions may not be listed. If a malfunction is not listed, or is not corrected by corrective action, notify your supervisor. Unless otherwise noted, when troubleshooting operation of container electrical system, all switches and circuit breakers shall be placed in operating positions with power connected. The electrical system schematic diagram (FO-1) and wire list (WP 0048 00) are located in Chapter 4.

WARNING



Container contains voltages that are dangerous if contacted. Take appropriate precautions when troubleshooting. Before performing continuity checks or replacing electrical components, make sure that electrical power is disconnected from circuit involved.

CHECKING FOR VOLTAGE THROUGH A CIRCUIT BREAKER

1. Obtain multimeter (WP 0058 00, SATS Base Tool Component List).
2. Refer to operator's manual and set meter to read at least 120 VAC.
3. Without touching wires, place one probe on buss bar that the circuit breaker is connected to, and the other probe to the wire connected to the circuit breaker. Meter will read voltage across breaker.
4. When breaker is off, voltage will be zero. When breaker is on, voltage will be 120 VAC.
5. 208 VAC will have three buss bars and three wires. Each wire can be checked using same procedures above.
6. To check for 208 VAC, set meter to read at least 208 VAC and check from buss bar to buss bar or from wire to wire on circuit breaker.

TM 9-4910-783-13&P

STANDARD AUTOMOTIVE TOOL SET (SATS)

0009 00

FIELD (UNIT) TROUBLESHOOTING

MALFUNCTION

TEST OR INSPECTION

CORRECTIVE ACTION

NOTE

Refer to electrical schematic (FO-1 (sheet 1 of 2)) for the following procedures.

1. NO POWER DISTRIBUTION TO CONTAINER.

Step 1. Check outside power is properly connected to service entrance connector on Power Input Receptacle, and check general condition of cable and connectors. If on board 10KW generator is used make sure generator main circuit breaker is closed.

Step 2. Start generator and check output from generator.

- a. If output from generator is present, go to step 3.
- b. If output does not exist from generator, refer to TM 9-6115-642-10 for further instructions on troubleshooting.

Step 3. Shut off generator.

Step 4. Disconnect cable from connector.

- a. Check continuity.
- b. If no continuity is present, replace cable.
- c. If continuity is present, go to next step.

Step 5. Check continuity from input connector to control panel.

- a. If no continuity is present, remove input connector mounting box.
- b. Check connector for continuity.
- c. If continuity is present, replace wiring to control panel.
- d. If no continuity is present, replace connector.
- e. Check master circuit breaker for continuity.
- f. If no continuity is present, replace master circuit breaker.

2. BLACKOUT LIGHT FAILS TO COME ON.

NOTE

Refer to electrical schematic (FO-2 (sheet 2 of 2)) for the following procedures.

TM 9-4910-783-13&P

FIELD (UNIT) TROUBLESHOOTING (cont)

- Step 1. Visually check to see if one blackout light bulb is on.
- Step 2. If one light is on, proceed to Step 4.
- Step 3. If both lights do not operate, proceed to Step 14.
- Step 4. Refer to WP 0031 00.
- Step 5. Test operation of blackout light fixture.
- Step 6. Turn off CB2.
- Step 7. Remove two set screws, globe guard, and light bulb.
- Step 8. Loosen two set screws, twist and remove socket adapter from surface box.
- Step 9. Turn CB2 on.
- Step 10. Turn blackout light switch to ON position.
- Step 11. Check for 120 VAC between black and white wires at surface box.
- Step 12. If voltage is present, replace fixture (WP 0031 00-1, Installation).
- Step 13. If no voltage is present, proceed to next step.
- Step 14. Turn off all circuit breakers.
- Step 15. Remove two outer screws and cover from S2 (blackout override switch).
- Step 16. Turn on all circuit breakers.
- Step 17. Check for 120 VAC at S2.
- Step 18. If 120 VAC is present, replace S2.
- Step 19. If 120 VAC is not present, proceed to next step.
- Step 20. Turn off all circuit breakers.
- Step 21. Check continuity from S2 to control panel.
- Step 22. Check continuity from light fixture to control panel.
- Step 23. If no continuity is present, replace wiring (WP 0036 00).
- Step 24. If continuity is present, check CB2 in control panel.
- Step 25. If no continuity is present, replace CB2 in control panel.

TM 9-4910-783-13&P

FIELD (UNIT) TROUBLESHOOTING (cont)

Step 26. Check for continuity between CB2 and CB23 in control panel.

Step 27. Refer to NO POWER DISTRIBUTION TO CONTAINER.

3. ALL FLUORESCENT LIGHTS FAIL TO COME ON.

NOTE

Refer to electrical schematic (FO-2 (pg 2 of 2)) for the following procedures.

Step 1. Check to insure that the blackout switch is in OVERRIDE position.

Step 2. Check and reset CB2.

Step 3. If lights still do not come on, proceed to next step.

Step 4. Turn off all circuit breakers.

Step 5. Remove screws and cover from power distribution unit.

Step 6. With all circuit breakers off, check for 120 VAC between each supply cable and ground (on the feed side), and 208 VAC between cables on the main circuit breaker.

Step 7. If voltage is not present, refer to NO POWER DISTRIBUTION TO CONTAINER.

Step 8. If voltage is present, turn on all circuit breakers.

Step 9. Check for 120 VAC through CB2 (See CHECKING FOR VOLTAGE THROUGH A CIRCUIT BREAKER).

Step 10. If voltage is not present, proceed to step 12.

Step 11. If voltage is present, proceed to step 18.

Step 12. Turn off all circuit breakers.

Step 13. Remove CB2 from panel and disconnect wire.

Step 14. Replace CB2 with the correct circuit breaker; reconnect wire.

Step 15. Turn on all circuit breakers.

Step 16. Check for 120 VAC through CB2 (See CHECKING FOR VOLTAGE THROUGH A CIRCUIT BREAKER).

Step 17. If voltage is not present, repeat steps 12 through 16.

Step 18. If voltage is present continue to next step.

Step 19. Turn off CB2.

TM 9-4910-783-13&P

FIELD (UNIT) TROUBLESHOOTING (cont)

Step 20. Go to light switch S3, remove two outer screws (Do not disconnect wires).

Step 21. Check for continuity across light switch S3 (Turning the switch on and off should interrupt the continuity).

Step 22. If you have continuity across light switch, proceed to step 30.

Step 23. If you do not have continuity across light switch, proceed to next step.

Step 24. Remove two inner screws and remove cover.

NOTE

Tag wires for reconnection.

Step 25. Loosen screws holding wires on light switch, and remove wires.

Step 26. Replace light switch S3 with new light switch.

Step 27. Check for continuity across light switch S3 (Turning switch on and off should interrupt continuity).

Step 28. If you have continuity across light switch, proceed to step 30.

Step 29. If you do not have continuity across light switch, repeat steps 25 through 27.

Step 30. Go to light, remove six retaining clips and remove plastic lens.

Step 31. Remove tube locks and fluorescent tubes.

Step 32. Inspect light bulb for damage.

Step 33. If damaged or burnt, replace with new fluorescent tube.

Step 34. If fluorescent tubes are not the problem, remove metal cover (Ballast and wires will now be exposed).

Step 35. Turn off all circuit breakers.

Step 36. Disconnect white and black wires from ballast by removing wire nuts.

Step 37. Make sure wires do not touch and turn on CB2.

Step 38. Check for 120 VAC between black and white wires.

Step 39. If 120 VAC is present, continue to step 30.

Step 40. If 120 VAC is not present replace wire.

TM 9-4910-783-13&P

FIELD (UNIT) TROUBLESHOOTING (cont)

Step 41. Turn off CB2.

Step 42. Remove screws holding ballast in place.

Step 43. Replace ballast with new ballast.

Step 44. Reinstall metal cover, fluorescent tubes, tube locks, and lens.

Step 45. Turn on CB2.

4. ONE OR MORE FLUORESCENT LIGHTS FAIL TO COME ON.

Step 1. If all fluorescent lights fail to come on refer to troubleshooting procedure 3, ALL FLUORESCENT LIGHTS FAIL TO COME ON.

Step 2. Go to the light or lights that fail to come on.

Step 3. Remove six retaining clips and plastic lens.

Step 4. Remove tube locks and fluorescent tubes.

Step 5. Inspect tube for damage.

Step 6. If damaged or burnt, replace with new fluorescent tube.

Step 7. If fluorescent tubes are not burnt or damaged proceed to step eight.

Step 8 Turn off CB2.

Step 9. Remove metal cover.

Step 10. Turn off all circuit breakers.

NOTE

Tag all wires for reconnection.

Step 11. Disconnect white and black wires from ballast by removing wire nuts.

Step 12. Ensure wires are not touching and turn on CB2.

Step 13. Check for 120 VAC between black and white wires.

Step 14. If 120 VAC is present, continue to step 17.

Step 15. If 120 VAC is not present, turn off CB2 and replace wire.

FIELD (UNIT) TROUBLESHOOTING (cont)

Step 17. Remove screws holding ballast in place.

Step 18. Replace ballast with new ballast.

Step 19. Reinstall ballast cover, fluorescent tubes, tube locks, and lens.

Step 20. Turn on CB2.

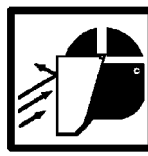
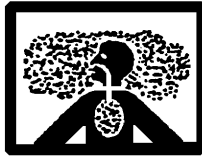
WARNING

In event of lamp breakage, care must be taken in removal of broken glass fragments and dust that may be dispersed within fixture. Inhalation of dust could cause serious injury. Ensure area is well ventilated.

Cleanup requires special care due to mercury droplet proliferation. Contact your supervisor for disposal guidance.

5. NO POWER AT ECU SUPPLY CONNECTOR.**NOTE**

Refer to electrical schematic (FO-1 (sheet 1 of 2)) for the following procedures.

Step 1. Check and reset CB3.

Step 2. Check connector for 120 VAC ground to each line and 208 VAC between lines.

Step 3. If voltage is not present, proceed to step 5.

Step 4. If voltage is present, proceed to step 22.

Step 5. Remove screws and cover from power distribution unit.

Step 6. With all circuit breakers off, check for 120 VAC between each supply cable and ground (on the feed side), and 208 VAC between cables on the main circuit breaker.

Step 7. If voltage is not present, refer to NO POWER DISTRIBUTION TO CONTAINER.

Step 8. If voltage is present, turn on all circuit breakers.

Step 9. Check for 120 VAC through each line of CB3 (See CHECKING FOR VOLTAGE THROUGH A CIRCUIT BREAKER).

TM 9-4910-783-13&P

FIELD (UNIT) TROUBLESHOOTING (cont)

Step 10. If voltage is not present, proceed to step 12.

Step 11. If voltage is present, proceed to step 18.

Step 12. Turn off all circuit breakers.

Step 13. Remove CB3 from the panel and disconnect the wire.

Step 14. Replace CB3 with the correct circuit breaker.

Step 15. Check for 120 VAC through each line of CB3 (See CHECKING FOR VOLTAGE THROUGH A CIRCUIT BREAKER).

Step 16. If voltage is not present, repeat steps 12 through 15.

Step 17. If voltage is present, continue to next step.

Step 18. Turn off CB3.

Step 19. Check for continuity between ECU connector and main circuit breaker.

Step 20. If no continuity is present, replace wire.

Step 21. If you have continuity continue to next step.

Step 22. Check connector for 120 VAC ground to each line and 208 VAC between lines.

Step 23. If voltage is not present, replace the wire.

Step 24. If voltage is present, plug into ECU.

Step 25. If ECU does not work, see ECU TM 5-4120-386-14.

6. NO POWER AT ONE OR BOTH EXTERIOR UTILITY OUTLETS.

Step 1. Check that the ground fault buttons have not been tripped.

Step 2. If ground fault buttons have been tripped, reset them.

Step 3. Check both outlets for 120 VAC.

Step 4. If voltage is not present at both outlets check and reset CB8.

Step 5. Check both outlets for 120 VAC.

Step 6. If voltage is not present at both outlets, proceed to step 8.

Step 7. If voltage is present at only one outlet, proceed to step 26.

Step 8. Turn off all circuit breakers.

TM 9-4910-783-13&P

FIELD (UNIT) TROUBLESHOOTING (cont)

- Step 9. Remove screws and cover from power distribution unit.
- Step 10. With all circuit breaker off, check for 120 VAC between each supply cable and ground (on the feed side), and 208 VAC between cables on the main circuit breaker.
- Step 11. If voltage is not present, refer to NO POWER DISTRIBUTION TO CONTAINER.
- Step 12. If voltage is present, turn on all circuit breakers.
- Step 13. Check for 120 VAC through CB8 (See CHECKING FOR VOLTAGE THROUGH A CIRCUIT BREAKER).
- Step 14. If voltage is not present, proceed to step 16.
- Step 15. If voltage is present, proceed to step 23.
- Step 16. Turn off all circuit breakers.
- Step 17. Remove CB8 from the panel and disconnect the wire.
- Step 18. Replace CB8 with the correct circuit breaker.
- Step 19. Turn on all circuit breakers.
- Step 20. Check for 120 VAC through CB8 (See CHECKING FOR VOLTAGE THROUGH A CIRCUIT BREAKER).
- Step 21. If voltage is not present, repeat steps 16 through 19.
- Step 22. If voltage is present continue to next step.
- Step 23. Check both outlets for 120 VAC.
- Step 24. If voltage is not present at both outlets, proceed to next step.
- Step 25. Turn off CB8.
- Step 26. Go to the outlet without voltage.
- Step 27. Remove one screw to remove weather protective cover from outlet.
- Step 28. Remove two screws to remove duplex outlet.
- Step 29. Turn on CB8.
- Step 30. Check for 120 VAC between the black and white wires.
- Step 31. If voltage is present, proceed to step 33.
- Step 32. If voltage is not present proceed to step 39.

TM 9-4910-783-13&P

FIELD (UNIT) TROUBLESHOOTING (cont)

Step 33. Turn off CB8.

Step 34. Remove the screws holding the wires onto the duplex and replace duplex with the correct duplex.

Step 35. Turn on CB8.

Step 36. Check for 120 VAC in the duplex.

Step 37. If voltage is present, reinstall duplex in container and weather cover on duplex.

Step 38. If voltage is not present, repeat steps 33 through 36.

Step 39. No voltage between wires, proceed to the next step.

Step 40. Turn off all circuit breakers.

Step 41. Check continuity from the duplex to the control panel.

Step 42. Check continuity on both the black and white wires.

Step 43. If no continuity, replace wire.

7. NO POWER AT INTERIOR UTILITY OUTLETS.

Step 1. Check that the ground fault buttons have not been tripped.

Step 2. If ground fault buttons have been tripped, reset them.

Step 3. Check all outlets for 120 VAC.

Step 4. If voltage is not present at all outlets, check and reset circuit breakers.

Step 5. Check both outlets for 120 VAC.

Step 6. If voltage is not present at all outlets, proceed to step 8.

Step 7. If voltage is present at only one outlet, proceed to step 26.

Step 8. Turn off all circuit breakers.

Step 9. Remove screws and cover from power distribution unit.

Step 10. With all circuit breakers off, check for 120 VAC between each supply cable and ground (on the feed side), and 208 VAC between cables on the main circuit breaker.

Step 11. If voltage is not present, refer to NO POWER DISTRIBUTION TO CONTAINER.

Step 12. If voltage is present, turn on all circuit breakers.

TM 9-4910-783-13&P

FIELD (UNIT) TROUBLESHOOTING (cont)

- Step 13. Check for 120 VAC through CB4 and CB6 (See CHECKING FOR VOLTAGE THROUGH A CIRCUIT BREAKER).
- Step 14. If voltage is not present, proceed to step 16.
- Step 15. If voltage is present, proceed to step 23.
- Step 16. Turn off all circuit breakers.
- Step 17. Remove CB4 or CB6 from the panel and disconnect the wire.
- Step 18. Replace CB4 or CB6 with the correct circuit breaker.
- Step 19. Turn on all circuit breakers.
- Step 20. Check for 120 VAC through CB4 or CB6 (See CHECKING FOR VOLTAGE THROUGH A CIRCUIT BREAKER).
- Step 21. If voltage is not present, repeat steps 16 through 19.
- Step 22. If voltage is present continue to next step.
- Step 23. Check both outlets for 120 VAC.
- Step 24. If voltage is not present at both outlets, proceed to next step.
- Step 25. Turn off CB4 and CB6.
- Step 26. Go to the outlet without voltage.
- Step 27. Remove one screw and weather protective cover from outlet.
- Step 28. Remove two screws and duplex outlet.
- Step 29. Turn on CB4 and CB6.
- Step 30. Check for 120 VAC between the black and white wires.
- Step 31. If voltage is present, proceed to step 33.
- Step 32. If voltage is not present proceed to step 39.
- Step 33. Turn off CB4 and CB6.
- Step 34. Remove the screws holding the wires onto the duplex and replace duplex with the correct duplex.

TM 9-4910-783-13&P

FIELD (UNIT) TROUBLESHOOTING (cont)

Step 35. Turn on CB4 and CB6.

Step 36. Check for 120 VAC in the duplex.

Step 37. If voltage is present, reinstall duplex in container and weather cover on duplex.

Step 38. If voltage is not present, repeat steps 33 through 36.

Step 39. No voltage between wires, proceed to the next step.

Step 40. Turn off all circuit breakers.

Step 41. Check continuity from the duplex to the control panel.

Step 42. Check continuity on both the black and white wires.

Step 43. If no continuity, replace wire.

8. GENERATOR SLIDE DOES NOT SLIDE.

Step 1. Check to insure both locking pins have been removed and are clear of generator slide.

Step 2. Check for any interference with generator slide.

Step 3. Remove all interferences.

Step 4. Check for dirt in slide rollers.

WARNING



Use of compressed air during cleaning can cause debris to hurt eye and skin. Use only with approved personal protective equipment.

Step 5. Use compressed air and blow out slide rollers.

Step 6. Move generator to maximum distance out one side.

Step 7. Clean both generator slide rails under exposed generator.

Step 8. Clean all exposed generator slide rollers.

Step 9. Check all exposed generator slide rollers to insure they roll freely.

TM 9-4910-783-13&P

STANDARD AUTOMOTIVE TOOL SET (SATS)

0009 00

FIELD (UNIT) TROUBLESHOOTING (cont)

- Step 10. Replace all generator slide rollers that do not roll freely (WP 0019 00).
- Step 11. Slide generator all the way to the opposite side of the container.
- Step 12. Clean both generator slide rails under exposed generator.
- Step 13. Clean all exposed generator slide rollers.
- Step 14. Check all exposed generator slide rollers to insure they roll freely.
- Step 15. Replace all generator slide rollers that do not roll freely (WP 0019 00).

END OF WORK PACKAGE

TM 9-4910-783-13&P

CHAPTER 4
MAINTENANCE INSTRUCTIONS
FOR
STANDARD AUTOMOTIVE TOOL SET (SATS)

TM 9-4910-783-13&P

FIELD (UNIT) PMCS INTRODUCTION

GENERAL

The SATS requires periodic inspection and cleaning to determine extent of preventive maintenance or repair necessary for proper operation.

For the container to be ready for use at all times, it must be inspected systematically so that defects may be discovered and corrected before they result in serious damage or failure.

1. Before you operate. Always keep in mind CAUTIONS and WARNINGS. Perform your “B – before” PMCS (Table 4-1).
2. While you operate. Always keep in mind CAUTIONS and WARNINGS. Perform your “D – during” PMCS (Table 4-1).
3. Monthly. Always keep in mind CAUTIONS and WARNINGS. Perform your “M – monthly” PMCS (Table 4-1).
4. If your equipment fails to operate, troubleshoot with proper equipment. Report deficiencies in accordance with DA PAM 750-8.

SPECIAL INSTRUCTIONS

The following actions apply while performing your PMCS:

1. Stop operation immediately if deficiency is noted during operation that would damage equipment.
2. Defects discovered during operation of equipment should be noted for future correction to be made as soon as operation has ceased.

PREVENTIVE MAINTENANCE CHECKS AND SERVICES ON GENERATOR AND ECU

Prior to startup of Generator and ECU, perform PMCS according to TM 9-6115-642-10 (Generator) and TM 5-4120-386-14 (ECU).

PREVENTIVE MAINTENANCE CHECKS AND SERVICES TABLE

Table 4-1 lists all PMCS to be performed. Use Figure 4-1 as reference.

NOTE

If equipment must be kept in continuous operation, check and service only those items that can be checked and serviced without disturbing operation. Make complete checks and services when equipment can be shut down. Inspect container for leaks.

TM 9-4910-783-13&P

STANDARD AUTOMOTIVE TOOL SET (SATS)

0010 00

RH Sidewall

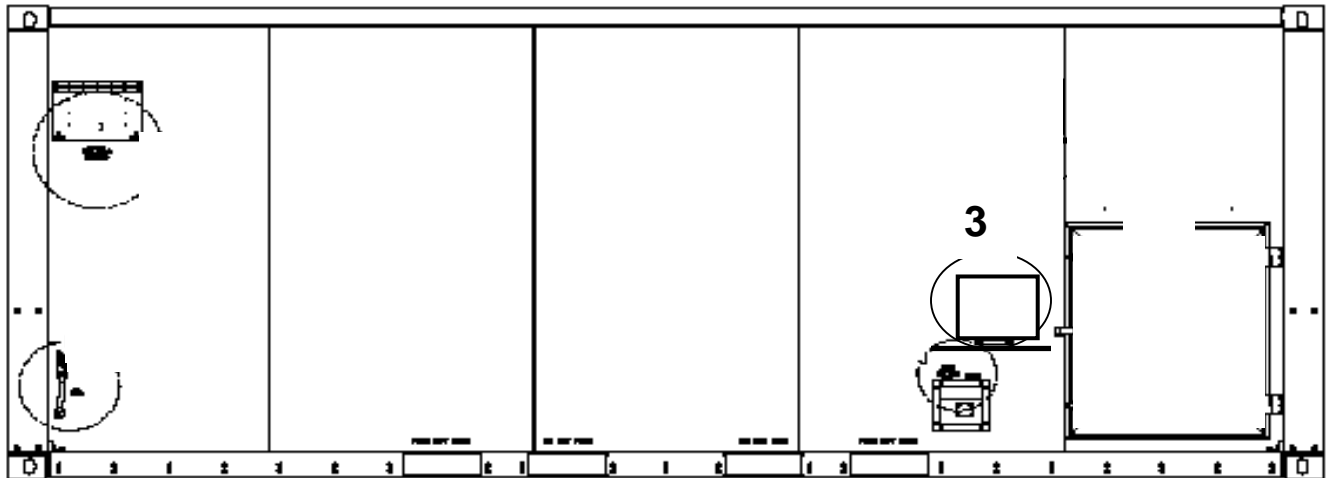

LH Sidewall

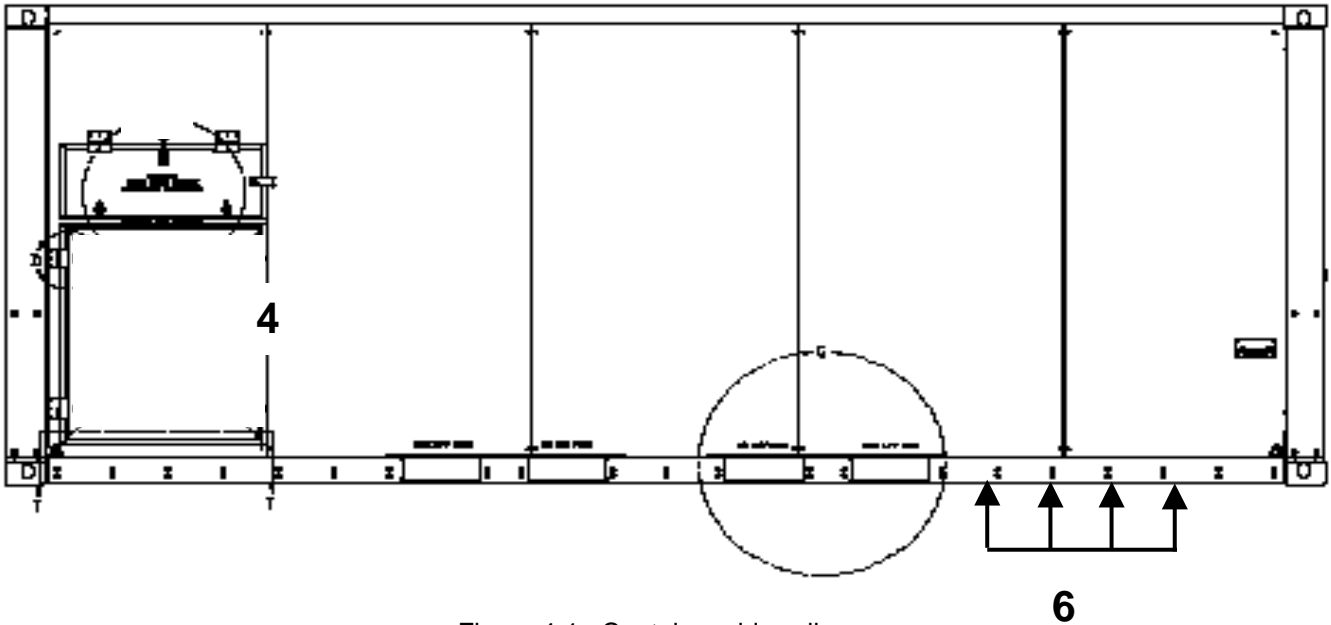

Figure 4-1. Container sidewalls.

Legend	
1	Decompression Panel
2	Door Strap
3	Communication Panel
4	Generator Access Panel
5	Generator Exhaust Panel
6	Detent Rail Mounting Points

TM 9-4910-783-13&P

Table 4-1. Preventive Maintenance Checks and Services

Item No.	B – Before			Item to be Inspected	D – During Procedures Check for and repair or adjust as necessary	M – Monthly For Readiness reporting, equipment is not Ready/ Available if:
	Interval B	D	M			
OUTSIDE – RH SIDEWALL						
1	•		•	RH sidewall panel	Inspect skin surface for paint damage, corrosion, cracks, or punctures	Cracks exists - Replace container
2	•		•	Door strap	Inspect for condition	
3	•		•	Decompression panel	Inspect for operation, condition, and seal	Door damaged or inoperative
4	•		•	Generator access panels	Inspect for condition of panels, lock hasp, and seal	
5	•		•	Generator safety strap	Inspect for condition	Strap frayed, Broken or missing
6	•		•	Generator slide	Inspect for condition and operation	Slide inoperative
7	•		•	Communication panel	Inspect for condition of panel and connectors	
8	•	•	•	Power input receptacle assembly	Inspect for damage to panel and receptacle	Damage exists that would allow an electrical hazard
9	•	•	•	208 VAC receptacle	Inspect for operation and condition	Damage exists that would allow an electrical hazard
10	•		•	Rivnut-detent rail mounting point	Inspect for condition	
11	•		•	Corner post and ISO fitting assembly	Inspect for condition and security	Damaged or inoperative
12	•	•	•	Container lift jack assemblies	Inspect for sinking into ground if container not level (check frequently during rainy conditions)	

TM 9-4910-783-13&P

Table 4-1. Preventive Maintenance Checks and Services (cont)

Item No.	B – Before			Item to be Inspected	D – During Procedures Check for and repair or adjust as necessary	M - Monthly For Readiness reporting, equipment is not Ready/ Available if:
	Interval B	D	M			
OUTSIDE – CARGO END WALL						
13			●	Container lift jack assemblies	Lubricate	
14	●		●	End wall panel	Inspect skin surface for paint damage, corrosion, cracks, or punctures	Cracks exist – replace container
15	●	●	●	120 VAC receptacle	Inspect for operation, condition, and seal	Damage exists that would allow an electrical hazard
16	●		●	ECU panel door	Inspect for condition of panel, lock hasp, and seal	
17	●		●	End wall vent panel door	Inspect for operation and condition	Door will not stay open or closed
OUTSIDE – LH SIDEWALL						
18	●		●	LH sidewall panel	Inspect skin surface for paint damage, corrosion, cracks, or punctures	Cracks exist – replace container
19	●		●	Generator access panels (fuel, exhaust)	Inspect for condition of panels, lock hasp, and seal	
20	●		●	Corner post and ISO fitting assembly	Inspect for condition and security	Damaged or inoperative
21	●	●	●	Container lift jack assemblies	Inspect for sinking into ground if container not level (check frequently during rainy conditions)	
22	●		●	Rivnut-detent rail mounting points	Inspect for condition	

TM 9-4910-783-13&P

Table 4-1. Preventive Maintenance Checks and Services (cont)

B – Before

D – During

M - Monthly

Item No.	Interval			Item to be Inspected	Procedures Check for and repair or adjust as necessary	For Readiness reporting, equipment is not Ready/ Available if:
	B	D	M			
OUTSIDE – PERSONNEL END WALL						
23			●	Container lift jack assemblies	Lubricate	
24	●		●	End wall panel	Inspect skin surface for paint damage, corrosion, cracks, or punctures	Cracks exist – replace container
25	●		●	Personnel door	Inspect for operation, condition, shims, and seal	Door inoperative
26	●	●	●	120 VAC receptacle	Inspect for operation, condition, and seal	Damage exists that would allow an electrical hazard
27	●		●	Utility steps	Inspect for operation and condition	
28			●	Roof panel	Inspect skin surface for paint damage, corrosion, cracks, or punctures	Cracks exist – replace container
INSIDE						
29	●		●	Padlock safety release mechanism	Inspect for operation and condition	Inoperative
30	●		●	Door stop assembly	Inspect for operation and condition	
31	●		●	Door gasket	Inspect for condition	
32	●		●	Floor panel	Inspect skin surface for paint damage, corrosion, cracks, or punctures	Cracks exist – Replace container
33	●		●	CO ₂ detector	Inspect for operation, condition, and replace batteries if needed	Inoperative

TM 9-4910-783-13&P

PREVENTIVE MAINTENANCE CHECKS AND SERVICES TABLE (cont)

Table 4-1. Preventive Maintenance Checks and Services (cont)

Item No.	B – Before			Item to be Inspected	D – During Procedures Check for and repair or adjust as necessary	M – Monthly For Readiness reporting, equipment is not Ready/ Available if:
	Interval B	D	M			
INSIDE (cont)						
34	•	•	•	Circuit breaker panel assembly	Inspect for damage to door and panel	Damage exists that would allow an electrical hazard
35	•	•	•	Circuit breakers	Inspect for operation, condition, and security	Damage exists that would allow an electrical hazard
36	•		•	ECU end wall panel	Inspect skin surface for paint damage, corrosion, cracks, or punctures	Cracks exist – replace container
37	•		•	Mechanical room wall panel	Inspect skin surface for paint damage, corrosion, cracks, or punctures	Damage exists that would allow exhaust from generator to enter container
38	•		•	Personnel door – end wall panel	Inspect skin surface for paint damage, corrosion, cracks, or punctures	Cracks exist – replace container
39	•	•	•	Receptacles	Inspect for operation, condition, and security	Damage exists that would allow an electrical hazard
40	•	•	•	Terminals / Connectors	Inspect for operation, condition, and security	Damage exists that would allow an electrical hazard
41	•	•	•	Area light assembly	Inspect for operation Inspect for damage	Damage exists that would allow an electrical hazard
42	•	•	•	Blackout light assembly	Inspect for operation	Damage exists that would allow an electrical hazard
43	•	•	•	Ceiling lights	Inspect for operation Inspect for damage	Damage exists that would allow an electrical hazard

TM 9-4910-783-13&P

PREVENTIVE MAINTENANCE CHECKS AND SERVICES TABLE (cont)

Table 4-1. Preventive Maintenance Checks and Services (cont)

Item No.	B – Before			Item to be Inspected	D – During Procedures Check for and repair or adjust as necessary	M – Monthly For Readiness reporting, equipment is not Ready/ Available if:
	Interval B	D	M			
44	•	•	•	Wall Switch	Inspect for operation	Damage exists that would allow an electrical hazard
45	•	•	•	Blackout switch	Inspect for operation	Damage exists that would allow an electrical hazard
46	•	•	•	Wiring	Inspect conduit for damage or disconnection	Damage exists that would allow an electrical hazard

WARNING



Isopropyl alcohol, dry cleaning solvents, and toluene are flammable and harmful to eyes, skin, and breathing passages. Observe all fire precautions. Use only with adequate ventilation and with approved personal protective equipment.

1. Clean dust, dirt, fingerprints, and other contamination from electrical parts by brushing with a paintbrush moistened with isopropyl alcohol. Wipe dry with clean, dry, lint-free cloth.
2. Clean dirt, grime, oil, and fingerprints from mechanical parts by wiping with a clean, lint-free cloth moistened with dry cleaning solvent. Wipe dry immediately with clean, dry, lint-free cloth.
3. Clean adhesive and anti-seize tape from mechanical parts by softening adhesive or anti-seize tape using paintbrush moistened with Toluene. Scrape away softened adhesive or anti-seize tape using a non-metallic brush.

TM 9-4910-783-13&P

STANDARD AUTOMOTIVE TOOL SET (SATS)

0010 00

PREVENTIVE MAINTENANCE CHECKS AND SERVICES (cont)

WARNING



Use of compressed air during cleaning can cause debris to hurt eye and skin. Use only with approved personal protective equipment.

4. Remove loose contamination with low-pressure dry air.

CAUTION

Do not use aromatic hydrocarbons or chlorinated solvents on exterior surfaces because they will react with plastic or rubber parts. Do not use abrasive cleaners or cleaning utensils, which may scratch painted surfaces.

5. Clean internal and external surfaces with anhydrous ethyl alcohol or a mild solution of detergent and water.

LUBRICATION

Container should be lubed monthly with Grease, Automotive and Armament (GAA) Lubricant (Item 17, WP 0057 00).

There are five lube points on container: One on door handle (1), one on each of four lift jack assemblies beneath Caution note (2), (Fig. 4-2).



Figure 4-2. Lube points for container.

TM 9-4910-783-13&P

REPAIR PARTS, SPECIAL TOOLS, TMDE, AND SUPPORT EQUIPMENT

COMMON TOOLS AND EQUIPMENT

For authorized common tools and equipment, refer to Modified Table of Organization and Equipment (MTOE) applicable to your unit.

REPAIR PARTS

Repair parts are listed and illustrated in the supporting information work package (WP 0053 00) of this manual.

CLASSIFICATION OF DEFECTS

1. Cosmetic - Minor surface scratches (WP 0040 00, Repair of Dents or Depressions).

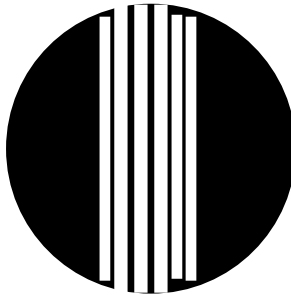

Figure 4-3. Cosmetic Damage

2. Surface Damage - Includes minor gouging of core (WP 0040 00, Repair of Dents or Depressions).

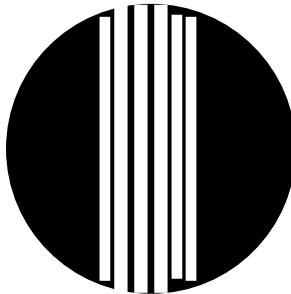

Figure 4-4. Surface Damage

CLASSIFICATION OF DEFECTS (cont)

3. Structural Damage – This is most extensive repair that can be performed on container. Container must be replaced if structural damage exists.



Figure 4-5. Structural Damage

TM 9-4910-783-13&P

STANDARD AUTOMOTIVE TOOL SET (SATS)

0012 00

FIELD (OPERATOR) MAINTENANCE PROCEDURES

GENERAL

Authorized maintenance procedures to be performed by operator include:

- Area Light Assembly Removal and Installation
- Ceiling Light: Lens, Fluorescent Tube, Starter, Ballast, & Fixture
- ECU Removal, Repair and Installation
- Generator Removal, Repair and Installation
- Generator Access Panels Removal and Installation

TM 9-4910-783-13&P

AREA LIGHT ASSEMBLY REMOVAL AND INSTALLATION

0013 00

THIS TASK COVERS:

- a. Removal b. Installation

INITIAL SETUP:

Tools and Special Tools:

References:

Materials/Parts:

Equipment Conditions:
All switches and circuit breakers placed in
ON position, power on

Personnel Required: 1

WARNING



Disconnect power of circuit involved by setting CB8 to OFF position.

a. REMOVAL

1. Place CB8 to OFF position.
2. Disconnect area light assembly connector from receptacle.
3. Collapse tripod legs (1) (Fig 4-6).



Figure 4-6. Area light in operational configuration.

TM 9-4910-783-13&P

b. INSTALLATION

1. Remove light assembly from inside personnel door.
2. Extend tripod legs and place on ground.
3. Connect area light assembly connector to receptacle.
4. Place CB8 to ON position and check light for operation.

END OF TASK

TM 9-4910-783-13&P

**CEILING LIGHT: LENS, FLUORESCENT TUBE, BALLAST, AND
FIXTURE REMOVAL AND INSTALLATION**

0014 00

THIS TASK COVERS:

a. Removal b. Installation

INITIAL SETUP:

Tools and Special Tools:
Base Tools
General Mechanic's Tool Kit (GMTK)

References:

Materials/Parts:

Equipment Conditions:
All switches and circuit breakers placed in
OFF position, power off

Personnel Required: 2

WARNING



Before attempting any repairs to light fixtures, confirm that power to light circuit is turned off at CB2.

LENS

a. REMOVAL

Unsnap white plastic retaining clips (1) that support lens in fixture. Remove lens (2) from light fixture (Fig. 4-7).

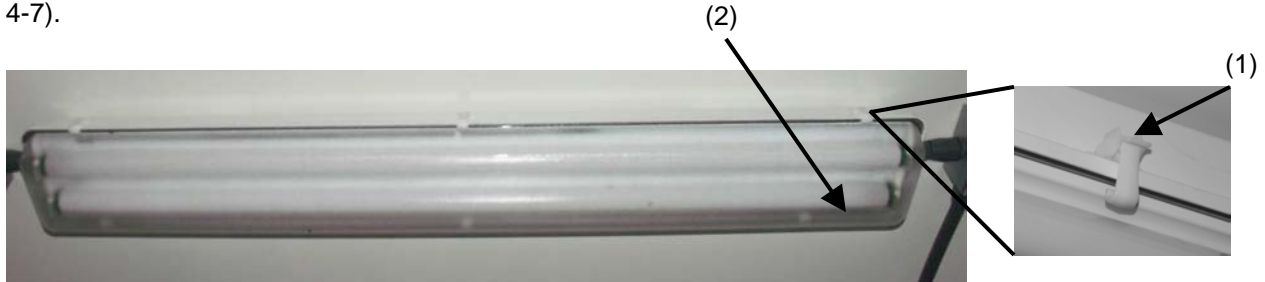

Figure 4-7. Ceiling light and white retaining clip.

b. INSTALLATION

Install replacement lens and secure to base with retaining clips.

TM 9-4910-783-13&P

CEILING LIGHT: LENS, FLUORESCENT TUBE, BALLAST, AND FIXTURE REMOVAL AND INSTALLATION

0014 00

FLUORESCENT TUBE

If one lamp in a fixture does not light, the problem may be a failed fluorescent tube.

a. REMOVAL

1. Remove lens by unsnapping white retaining clips that support lens in fixture. Remove lens from light fixture.

WARNING



In event of lamp breakage, care must be taken in removal of broken glass fragments and dust that may be dispersed within fixture. Inhalation of dust could cause serious injury. Ensure area is well ventilated.

Cleanup requires special care due to mercury droplet proliferation. Contact your supervisor for disposal guidance.

2. Release defective tube by removing tube locks at both ends of tube toward ends of fixture. Rotate bulb 90°. If set down harshly it will easily shatter and release hazardous material into the air.

b. INSTALLATION

Install replacement tube and lock it in place by rotating it 90°. Replace tube locks at both ends of tube. Replace lens by installing lens back onto fixture and reinstalling white retaining clips.

BALLAST

If both lamps in a fixture do not light, problem may be a failed ballast (1) (Fig. 4-8).



Figure 4-8. Ballast in light fixture.

a. REMOVAL

1. Disconnect power by turning off CB2.

TM 9-4910-783-13&P

CEILING LIGHT: LENS, FLUORESCENT TUBE, BALLAST, AND FIXTURE REMOVAL AND INSTALLATION

0014 00

a. REMOVAL (cont)

2. Unsnap white retaining clips that support lens in the fixture. Remove lens from light fixture.
3. Remove tube locks holding fluorescent tubes in place.
4. Remove fluorescent tubes.
5. Turn latch, unsnap and remove metal cover (1) (Fig. 4-9).



Figure 4-9. Ceiling light with bulbs removed.

6. Cut wire connecting defective ballast (green, black, and white wires) so that crimp connectors are removed with ballast. Strip insulation from ends of fixture wire, exposing about ¼ inch (6.35 mm) bare wire.
7. Remove bolt holding ballast and remove ballast.

b. INSTALLATION

NOTE

Do not over-tighten bolt in ballast.

1. Mount replacement ballast in place of old one just removed and replace bolt. Connect wires on replacement ballast to wires stripped in step (6). Protect connections with wire nuts.
2. Replace metal cover removed on step (5).
3. Replace lens by installing into fixture and reinstall white plastic retaining clips.
4. Turn CB2 back on.

LIGHT FIXTURE

a. REMOVAL

1. Disconnect power by shutting off (CB2).
2. Remove lens, fluorescent tubes, and metal cover from fixture (see above steps).

NOTE

If removing light closest to door, remove wire clamps from both sides.

TM 9-4910-783-13&P

CEILING LIGHT: LENS, FLUORESCENT TUBE, BALLAST, AND FIXTURE REMOVAL AND INSTALLATION

0014 00

a. REMOVAL (cont)

3. Loosen conduit wire clamp (1) (Fig. 4-10) from conduit connector.

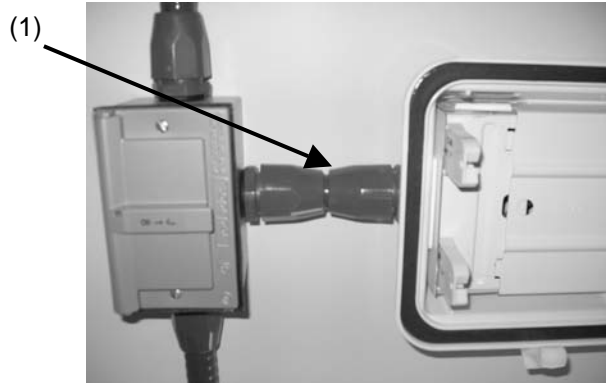

Figure 4-10. Conduit connecting ceiling light and outlet box.

4. Disconnect fixture wire from distribution wire by removing wire nuts and separating wires.

WARNING



Wear eye protection when removing rivnuts. Flying particles may damage eyes.

5. Remove two rivnuts (WP 0037 00, Removal) holding fixture against ceiling and slide distribution wire through conduit connector while removing light fixture from ceiling.
6. Remove conduit connector from each end of light assembly, if applicable.

b. INSTALLATION

1. Install conduit connector to each end of light assembly, if applicable.
2. Install distribution wire through conduit connector and support replacement fixture in position. Secure with two rivnuts (WP 0037 00, Installation).
3. Connect fixture wires to supply wires and replace wire nuts previously removed. Secure insulated wire nut.
4. Replace metal cover, fluorescent tubes, retaining clips, and lens.
5. Turn CB2 on and check light for operation.

END OF TASK

TM 9-4910-783-13&P

ECU: REPAIR, REMOVAL AND INSTALLATION

0015 00

THIS TASK COVERS:

- a. Repair b. Removal c. Installation

INITIAL SETUP:

Tools and Special Tools:
Base Tools
GMTK

References:
TM 5-4120-386-14

Materials/Parts:

Equipment Conditions:
All switches and circuit breakers placed in
OFF position, power off

Personnel Required: 4

a. REPAIR

To troubleshoot and repair ECU, refer to TM 5-4120-386-14.

b. REMOVAL

1. Inside container remove electrical connector from power input jack (J2) on ECU.
2. Ensure container has been placed on ground prior to removing ECU (WP 0047 00, Removing Container from Trailer).
3. Open ECU panel by unscrewing five thumbscrews (1) (Fig 4-11).

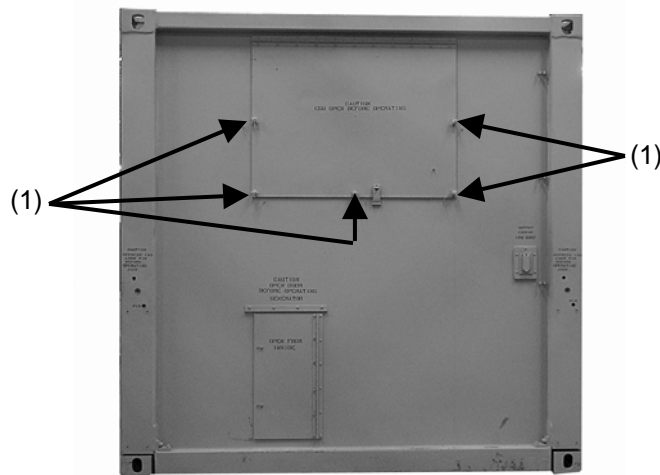

Figure 4-11. Front view of SATS.

TM 9-4910-783-13&P

b. REMOVAL (cont)

4. Using prop rod (1), prop open ECU panel (Fig.4-12).

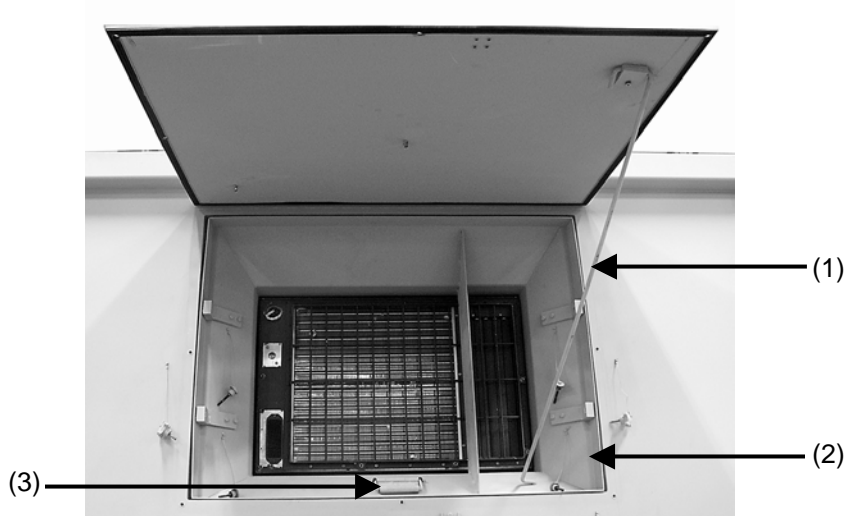

Figure 4-12. ECU panel.

5. Unscrew and remove four thumbscrews from shroud (2) (Fig. 4-12).

6. Replace prop rod and manually hold panel door open.

7. Using handle (3), pull ECU straight out as far as it will go (Fig. 4-12).

8. Remove two 1/4" bolts (1) and lock washers located on vertical portion of both sides of shroud bracket (2) and remove shroud (3) (Fig. 4-13). Discard lock washers.

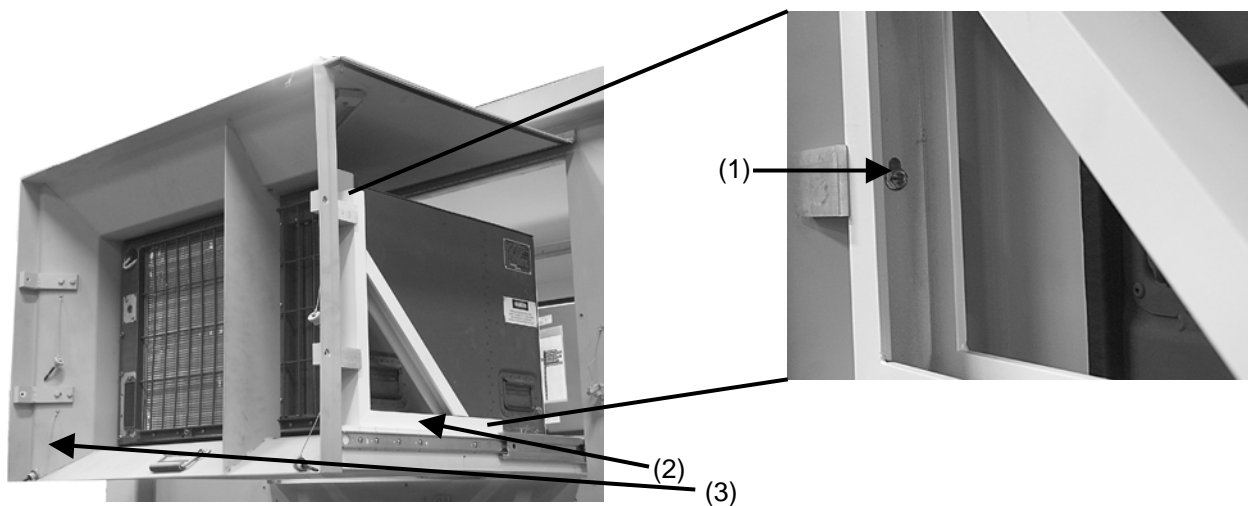

Figure 4-13. ECU shroud and bracket.

TM 9-4910-783-13&P

b. REMOVAL (cont)

9. Remove four 3/8" bolts (1), washers, spacers, rubber grommets and spacers located on underside of ECU (Fig 4-14).

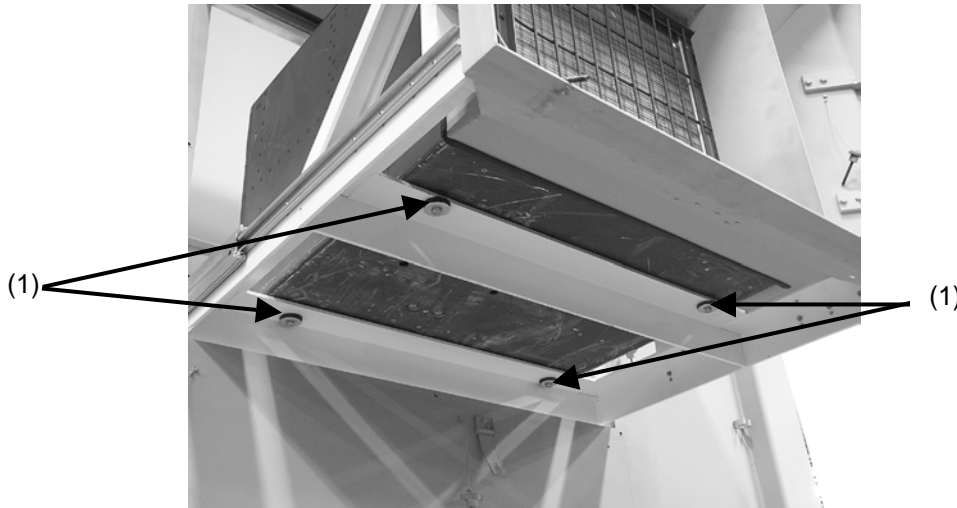

Figure 4-14. Underside of ECU.

10. Lift door off top of ECU.

CAUTION

ECU weighs 187 lbs., requires four-person lift.

11. Remove ECU from ECU slide.

c. INSTALLATION

1. Ensure container has been placed on ground prior to installing ECU (WP 0047 00, Removing Container from Trailer).

2. Manually open ECU panel.

3. Place ECU onto ECU slide.

4. Replace four 3/8" bolts, washers, spacers and four rubber grommets on underside of ECU.

5. Replace shroud and secure shroud bracket with 3/8" bolts.

6. Replace four bolts and new lock washers to front of shroud.

7. Push ECU into compartment.

8. Connect power input jack (J2) to ECU. Check ECU for operation.

END OF TASK

TM 9-4910-783-13&P

GENERATOR: REPAIR, REMOVAL, AND INSTALLATION

0016 00

THIS TASK COVERS:

- a. Repair b. Removal c. Installation

INITIAL SETUP:

Tools and Special Tools:

Base Tools
GMTK

References:

TM 9-6115-642-10

Materials/Parts:

Equipment Conditions:

All switches and circuit breakers placed in
OFF position, power off
Container level according to inclinometer
readings on outside of container

Personnel Required: 3

a. REPAIR

To troubleshoot and repair Generator, refer to TM 9-6115-642-10.

b. REMOVAL

1. Ensure container has been placed on ground prior to removing Generator (WP 0047 00, Removing Container from Trailer).
2. Remove T-pin (1) from each side of generator slide (Fig. 4-15).



Figure 4-15. Generator T-pin.

TM 9-4910-783-13&P

b. REMOVAL (cont)

- Slide generator out as far as it will go to one side (Fig.4-16).

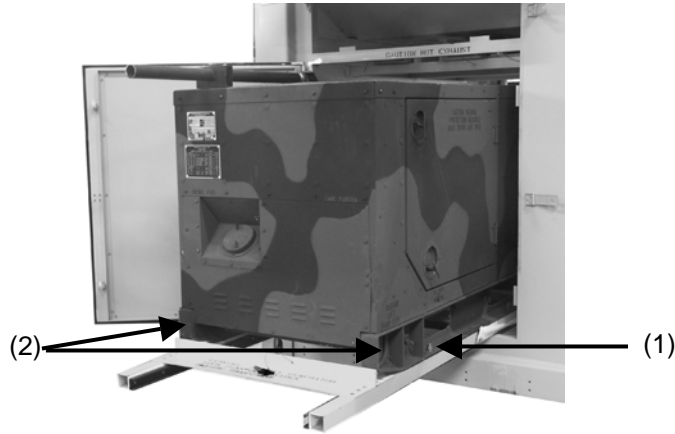

Figure 4-16. Generator slid out of mechanical room.

- Using a lifting strap, attach hooks to lift rings (2) on each side to end of generator that has been slid out of mechanical room.
- Using a lift, attach lift strap and remove any slack in strap to support weight of generator.

CAUTION

Improper lifting technique may cause generator to slide off frame assembly.

- Using a 9/16" wrench (WP 0058 00, SATS Base Tool Component List), remove bolt securing safety straps (1) to mechanical room floor (Fig. 4-17).

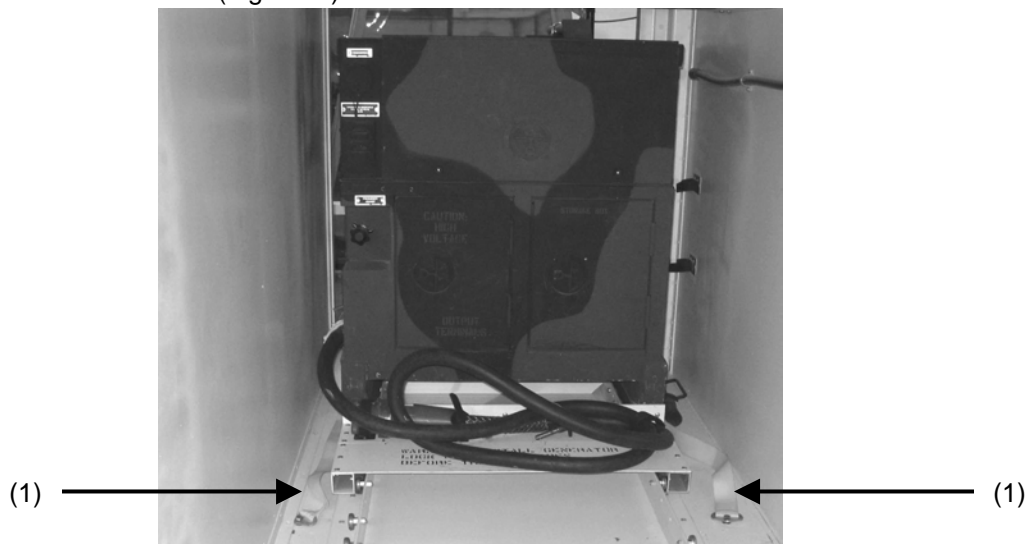

Figure 4-17. Generator in mechanical room.

TM 9-4910-783-13&P

b. REMOVAL (cont)

7. Carefully continue sliding generator out of mechanical room while supporting one end with lift until all but one foot of generator slide is outside of mechanical room.
8. Block and shore end of slide that is farthest away from container using adequate dunnage (capable of supporting 1500 lbs) while keeping generator and slide level.
9. Attach another lift strap (identical to first used) to provided rings at opposite end of generator.
10. Lift generator and slide from container and place on ground using material handling equipment.
11. Once generator and slide have been placed on ground, remove four sets of washers, lock washers, nuts, and bolts using a $\frac{3}{4}$ " wrench (WP 0058 00, SATS Base Tool Component List).
12. Generator can now be removed from slide using available material handling equipment.

c. INSTALLATION

1. Ensure container has been placed on ground prior to installing generator (WP 0047 00, Removing Container from Trailer).
2. Using material handling equipment, place generator on slide.
3. Attach slide to generator using four sets of bolts, nuts, new lock washers and washers.
4. Using two lift straps, attach hooks to two lift rings on each side of generator.
5. Using a lift, attach lift straps and lift generator and slide.

CAUTION

Improper lifting technique may cause generator to slide off frame assembly.

6. Place generator and slide into mechanical room about 12 inches in.
7. Block and shore end of slide that is farthest away from container using adequate dunnage (capable of supporting 1500 lbs) while keeping generator and slide level.
8. Remove lift strap from end of generator closest to mechanical room.
9. Slowly push generator and slide into mechanical room.
10. Replace bolt securing safety straps (1) from generator to mechanical room floor (Fig. 4-17).
11. Replace T-pin (1) on each side of generator slide (Fig.4-15).

END OF TASK

TM 9-4910-783-13&P

GENERATOR ACCESS PANELS: REMOVAL AND INSTALLATION

0017 00

THIS TASK COVERS:

- a. Removal b. Installation

INITIAL SETUP:

Tools and Special Tools:
Base Tools
GMTK

References:

Materials/Parts:

Equipment Conditions:
All switches and circuit breakers placed in
ON position, power on

Personnel Required: 1

a. REMOVAL

1. Remove three rivets (1) (Fig. 4-18) from side of hinge attached to container wall (WP 0037 00, Rivet Removal).

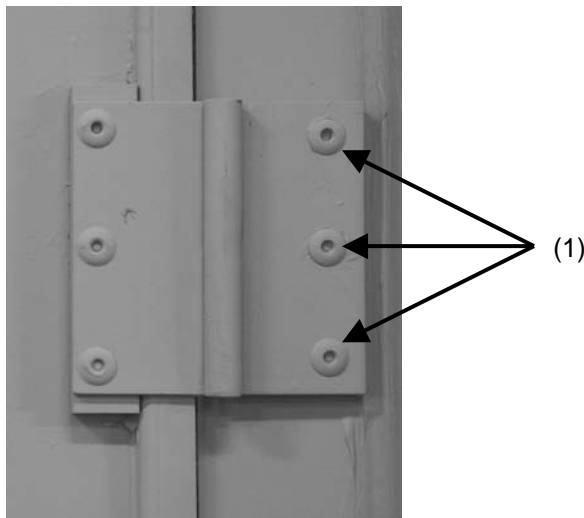

Figure 4-18. View of panel door hinge.

2. Rotate T-handles 180°.
3. Remove panel.

b. INSTALLATION

1. Lift panel and align hinge halves with rivet holes on container.
2. Install rivets (WP 0037 00, Rivet Installation).
3. Once panel is in place, turn T-handles 180° to secure.

END OF TASK

TM 9-4910-783-13&P

STANDARD AUTOMOTIVE TOOL SET (SATS)

0018 00

FIELD (UNIT) MAINTENANCE PROCEDURES

This section contains the following maintenance procedures for container:

LIST OF FUNCTIONS

Function	Work Package
Generator Slide Caster Removal and Installation.....	0019 00
Generator Slide Removal and Installation	0020 00
Generator Slide Frame Removal and Installation.....	0021 00
ECU Slide Removal and Installation	0022 00
Personnel Door Internal Handle and Locking Bar Removal and Installation.....	0023 00
Panel Hasp Removal and Installation.....	0024 00
Computer Cabinet Removal and Installation	0025 00
Main Generator Cable Removal and Installation	0026 00
Circuit Breaker Panel Assembly Removal, Repair, and Installation	0027 00
Power Input Receptacle Assembly Removal, Repair, and Installation.....	0028 00
Communication Panel Assembly Removal and Installation.....	0029 00
Utility Step Removal and Installation	0030 00
Blackout Light Assembly Removal, Repair, and Installation.....	0031 00
Ceiling Light Removal, Repair, and Installation	0032 00
Internal Receptacle Outlets Removal, Repair, and Installation	0033 00
Wall Switch Removal and Installation.....	0034 00
Limit Switch Removal, Repair, Installation, and Adjustment.....	0035 00
Wiring Removal, Repair, and Installation.....	0036 00
Rivet Removal and Installation	0037 00
Door Gasket Removal and Installation	0038 00
Main Door Removal and Installation	0039 00
Repair of Dents or Depressions – Aluminum Bonded Material	0040 00
Repair of Puncture Less than ½ in (12.70 mm) – Aluminum Bonded Material.....	0041 00
Repair of Fracture Less than 1 ½ x 3 in (38.10 x 76.20 mm) – Aluminum Bonded Mat'l	0042 00
Rivnut Repair	0043 00
Container Lift Jack Assembly Removal and Installation	0044 00
Caulking Repaired Areas	0045 00
Paint Refinishing	0046 00

TM 9-4910-783-13&P

GENERATOR SLIDE CASTER REMOVAL AND INSTALLATION

0019 00

THIS TASK COVERS:

- a. Removal b. Installation

INITIAL SETUP:

Tools and Special Tools:

Base Tools
GMTK

References:

Materials/Parts:

Equipment Conditions:

All switches and circuit breakers placed in
OFF position, power off
Container level according to inclinometer
readings on outside of container

Personnel Required: 1

a. REMOVAL

1. Locate caster(s) (1) needing replacement (Fig. 4-19).

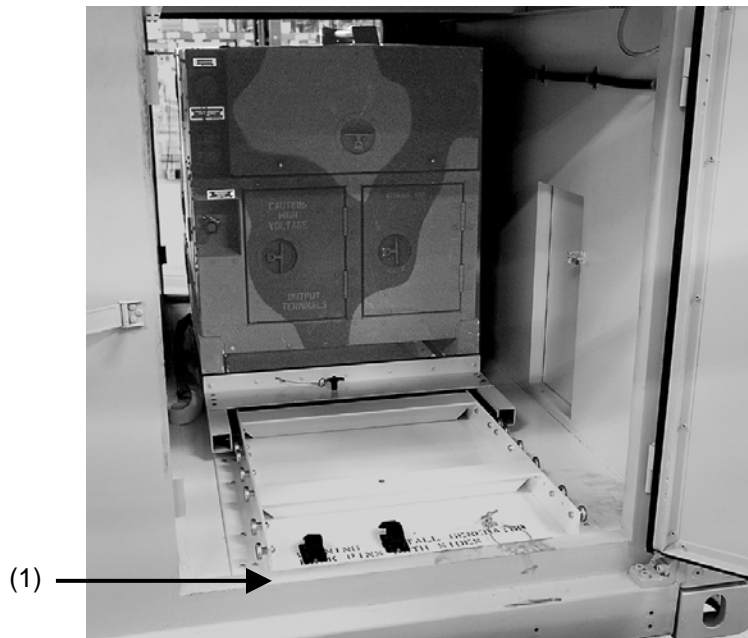

Figure 4-19. View of mechanical room showing generator slide and casters.

2. Slide generator to a position that will allow easy access to damaged caster.
3. Using a 1/2" wrench and a 9/16" open end wrench (WP 0058 00, SATS Base Tool Component List), remove 5/16" nut holding caster in place.

TM 9-4910-783-13&P

GENERATOR SLIDE CASTER REMOVAL AND INSTALLATION

0019 00

a. REMOVAL (cont)

4. Remove caster.

b. INSTALLATION

1. Replace caster.

2. Secure caster using 5/16" nut.

END OF TASK

TM 9-4910-783-13&P

THIS TASK COVERS:

- a. Removal
- b. Installation

INITIAL SETUP:

Tools and Special Tools:

- Base Tools
- GMTK

References:

Materials/Parts:

Equipment Conditions:

- All switches and circuit breakers placed in OFF position, power off
- Container level according to inclinometer readings on outside of container

Personnel Required: 2

a. REMOVAL

1. Remove generator from mechanical room (WP 0016 00, Removal).

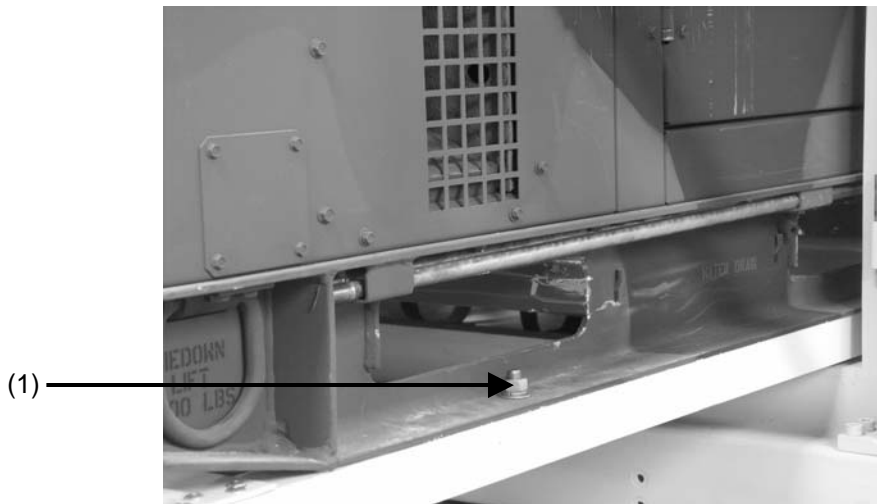

Figure 4-20. Bottom of Generator on slide.

2. Slide will be attached to generator when it is removed.
3. Remove four sets of washer, lock washer, nut, and bolt (1) using a 3/4" wrench (WP 0058 00, SATS Base Tool Component List). (Fig. 4-20)
4. Generator can now be removed from slide using available material handling equipment.

b. INSTALLATION

1. Using material handling equipment, place generator on slide.

TM 9-4910-783-13&P

b. INSTALLATION (cont)

2. Attach slide to generator using four sets of bolts, nuts, new lock washers and washers.
3. Install slide and generator in container by following steps four through eleven in WP 0016 00, Removal.

END OF TASK

TM 9-4910-783-13&P

THIS TASK COVERS:

- a. Removal
- b. Installation

INITIAL SETUP:

Tools and Special Tools:

- Base Tools
- GMTK

References:

Materials/Parts:

Equipment Conditions:

- All switches and circuit breakers placed in OFF position, power off
- Container level according to inclinometer readings on outside of container

Personnel Required: 2

a. REMOVAL

1. Remove generator from mechanical room (WP 0016 00).
2. Remove a total of 36 rivets (WP 0037 00) from both sides of slide frame (1) (Fig. 4-21).

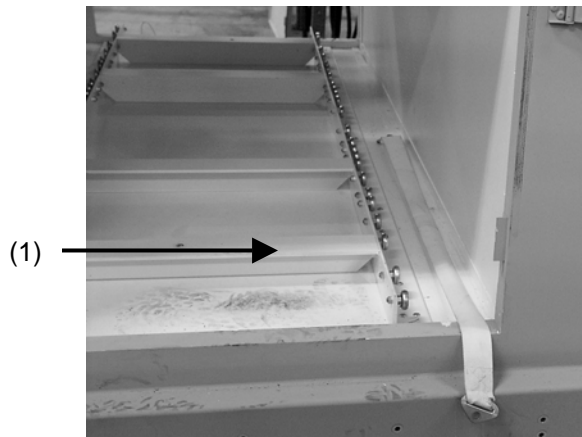

Figure 4-21. View of generator in mechanical room.

3. Remove slide frame from mechanical room from either side.

b. INSTALLATION

1. Place slide frame in mechanical room from either side of container.
2. Align rivet holes in slide frame with rivet holes in floor of mechanical room.
3. Secure with a total of 36 rivets in pre-drilled holes.

END OF TASK

TM 9-4910-783-13&P

ECU SLIDE REMOVAL AND INSTALLATION

0022 00

THIS TASK COVERS:

- a. Removal b. Installation

INITIAL SETUP:

Tools and Special Tools:

Base Tools
GMTK

References:

Materials/Parts:

Equipment Conditions:

All switches and circuit breakers placed in
OFF position, power off

Personnel Required: 2

a. REMOVAL

1. Remove ECU (WP 0015 00).
2. Using a 5/32 allen wrench (WP 0058 00, SATS Base Tool Component List), remove a total of 14 bolts and lock nuts from ECU slide (1) (Fig. 4-22). Discard lock nuts.

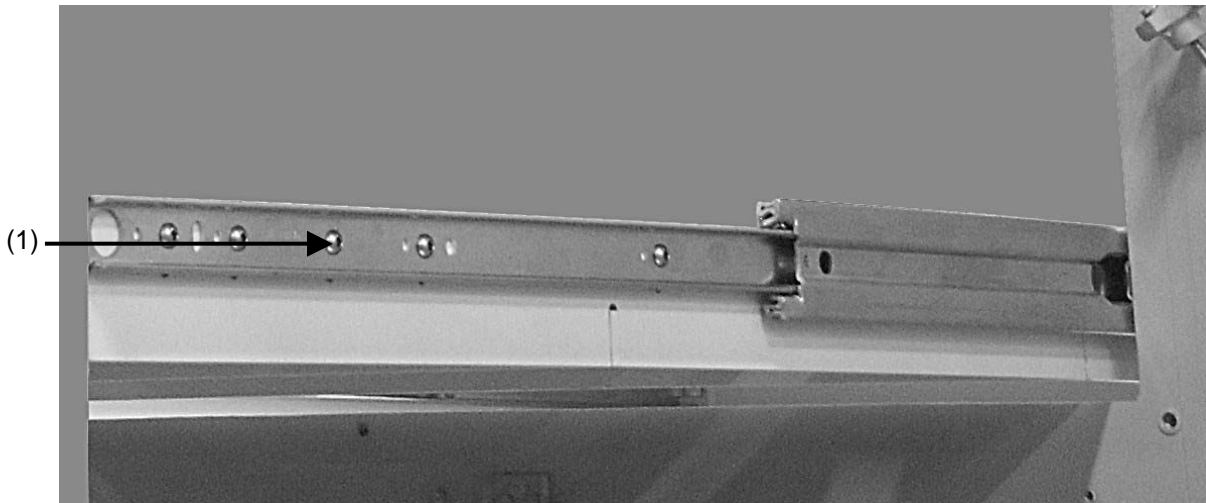

Figure 4-22. Side view of ECU.

3. Remove slide frame.

TM 9-4910-783-13&P

a. REMOVAL (cont)

4. Using an allen wrench, remove a total of 14 bolts and lock nuts from the slide mechanism (1) (Fig. 4-23). Discard lock nuts.



Figure 4-23. View of ECU compartment from inside container.

5. Remove slide mechanism.

b. INSTALLATION

1. Replace slide mechanism.
2. Secure with 14 allen head bolts and new lock nuts.
3. Attach slide frame.
4. Secure with 14 allen head bolts and new lock nuts.
5. Replace ECU (WP 0015 00).

END OF TASK

TM 9-4910-783-13&P

PERSONNEL DOOR INTERNAL HANDLE AND LOCKING BAR
REMOVAL AND INSTALLATION

0023 00

THIS TASK COVERS:

- a. Removal b. Installation

INITIAL SETUP:

Tools and Special Tools:

Base Tools
GMTK

References:

Materials/Parts:

GAA Lubricant (Item 17, WP 0057 00)

Equipment Conditions:

All switches and circuit breakers placed in
ON position, power on

Personnel Required: 1

a. REMOVAL

1. Using a 3/16 hex key, remove four bolts and spacers from handle (1) and locking bar (2) (Fig. 4-24).

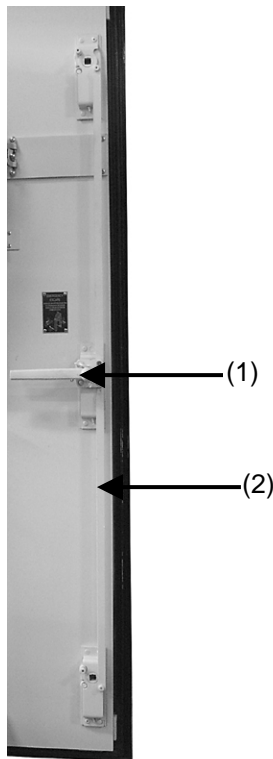

Figure 4-24. Handle and locking bar located on personnel door.

2. Remove handle and locking bar.

TM 9-4910-783-13&P

PERSONNEL DOOR INTERNAL HANDLE AND LOCKING BAR REMOVAL AND INSTALLATION

0023 00

b. INSTALLATION

1. Using two hex head bolts (1) and spacers, secure locking bar in place (Fig. 4-25).

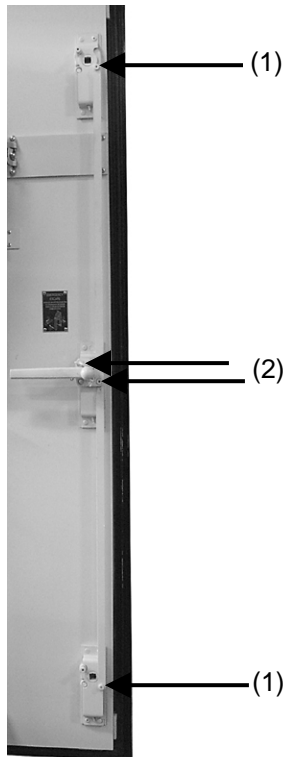

Figure 4-25. Handle and locking bar located on personnel door.

2. Replace handle and secure with two hex head bolts (2) and spacers.
3. Upon installation of door handle, lubricate with GAA Lubricant (Item 17, WP 0057 00).

END OF TASK

TM 9-4910-783-13&P

THIS TASK COVERS:

- a. Removal b. Installation

INITIAL SETUP:

Tools and Special Tools:

- Base Tools
- GMTK

References:

Materials/Parts:

Equipment Conditions:

- All switches and circuit breakers placed in ON position, power on

Personnel Required: 1

a. REMOVAL

1. Remove rivets (WP 0037 00) from damaged portion (male (1) or female (2)) of hasp (Fig. 4-26).

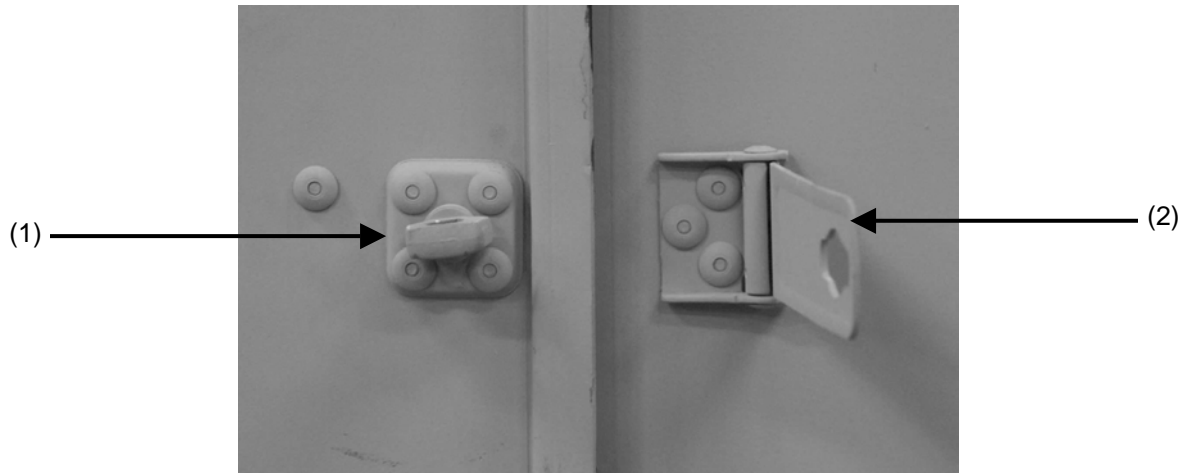

Figure 4-26. Panel hasp.

2. Remove hasp.

b. INSTALLATION

1. Replace applicable portion of hasp.
2. Secure with rivets (WP 0037 00).

END OF TASK

TM 9-4910-783-13&P

THIS TASK COVERS:

- a. Removal
- b. Installation

INITIAL SETUP:

Tools and Special Tools:
Base Tools
GMTK

References:

Materials/Parts:

Equipment Conditions:
All switches and circuit breakers placed in
OFF position, power off

Personnel Required: 2

a. REMOVAL

1. Using a 7/16" wrench (WP 0058 00, SATS Base Tool Component List), remove four bolts (1) and four lock washers from top of computer station (Fig. 4-27). Discard lock washers.

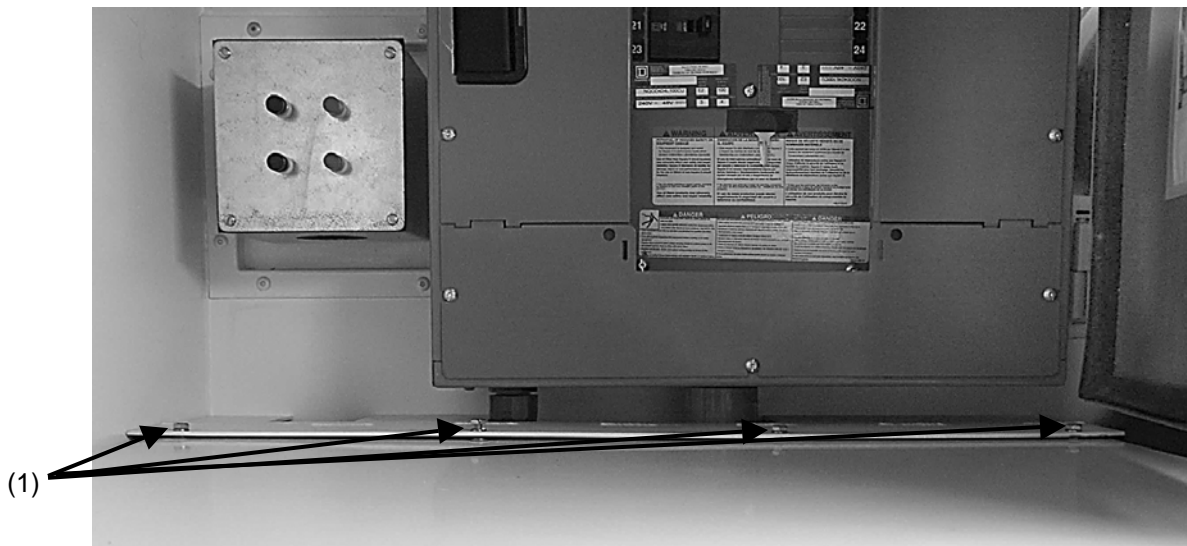

Figure 4-27. Top of computer cabinet.

TM 9-4910-783-13&P

a. REMOVAL (cont)

2. Using a 9/16" wrench (WP 0058 00, SATS Base Tool Component List) remove two bolts (1) at bottom of cabinet (Fig. 4-28).



Figure 4-28. Bottom of computer cabinet.

3. Pull cabinet straight out.

b. INSTALLATION

1. Position computer cabinet in far right hand corner of interior of container.
2. Slide cabinet toward wall until cabinet engages with the brackets mounted on container floor.
3. Secure to floor using 3/8" bolts.
4. Place four new lock washers and four 1/4" bolts in provided holes on top of computer station.

END OF TASK

TM 9-4910-783-13&P

THIS TASK COVERS:

- a. Removal
- b. Installation

INITIAL SETUP:

Tools and Special Tools:
Base Tools
GMTK

References:

Materials/Parts:

Equipment Conditions:
All switches and circuit breakers placed in
OFF position, power off

Personnel Required: 1

a. REMOVAL

1. Disconnect power to generator.
2. Open generator access panel on side of container that houses power input receptacle.
3. Open door to generator terminal compartment.
4. Loosen lug nut on neutral (N) position (1) and remove yellow wire. (Fig. 4-29)

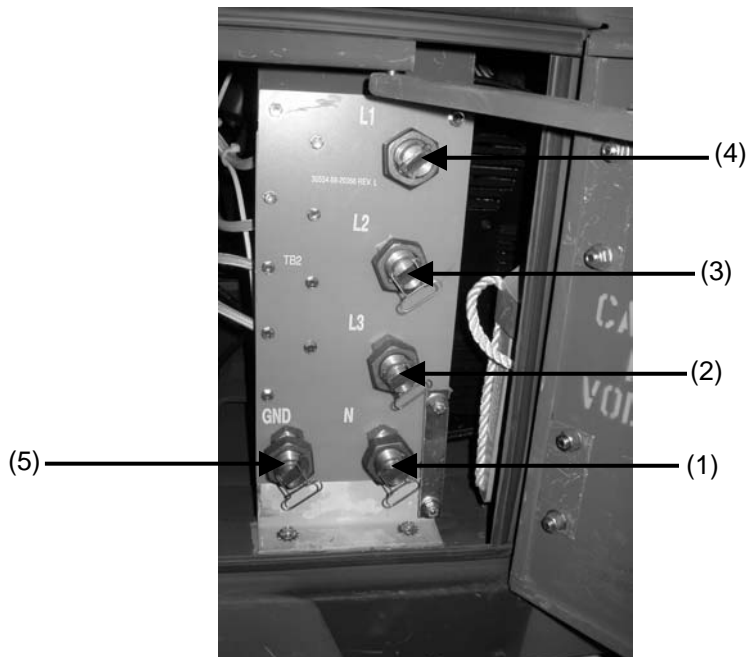

Figure 4-29. Generator terminal compartment.

TM 9-4910-783-13&P

a. REMOVAL (cont)

5. Loosen lug nut on ground (GND) position (5) and remove the bundle of four green wires.
6. Loosen lug nut on L3 position (2) and remove orange wire.
7. Loosen lug nut on L2 position (3) and remove red wire.
8. Loosen lug nut on L1 position (4) and remove black wire.
9. Thread cable assembly back through waterproof bag (1) in generator terminal compartment. (Fig. 4-31)

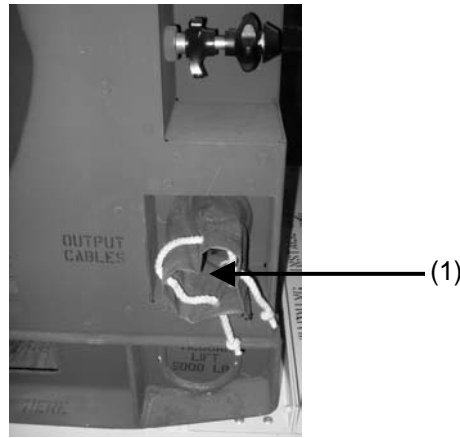

Figure 4-30. Waterproof bag in generator terminal compartment.

b. INSTALLATION

1. Disconnect power to generator.
2. Open generator access panel on side of container that houses power input receptacle.
3. Thread cable assembly (Fig. 4-31) through waterproof bag (1) (Fig. 4-30) into generator terminal compartment.

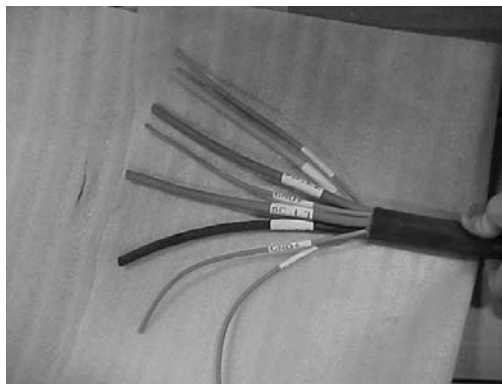

Figure 4-31. Wire end of main generator cable.

TM 9-4910-783-13&P

b. INSTALLATION (cont)

4. Install black wire into L1 position (4) and tighten lug nut (Fig. 4-29).
5. Install red wire into L2 position (3) and tighten lug nut (Fig. 4-29).
6. Install orange wire into L3 position (2) and tighten lug nut (Fig. 4-29).
7. Install four green wires into GND position (5) and tighten lug nut (Fig. 4-29).
8. Install yellow wire into N position (1) and tighten lug nut (Fig. 4-29).
9. Reconnect generator power.

END OF TASK

TM 9-4910-783-13&P

CIRCUIT BREAKER PANEL ASSEMBLY REMOVAL, REPAIR, AND INSTALLATION

0027 00

THIS TASK COVERS: a. Removal b. Disassembly
c. Cleaning, Inspection d. Repair e. Assembly f. Installation

INITIAL SETUP:

Tools and Special Tools:
Base Tools
GMTK

References:

Materials/Parts:

Equipment Conditions:
All switches and circuit breakers placed in
OFF position, power off

Personnel Required: 1

CIRCUIT BREAKER

a. REMOVAL

WARNING



Disconnect electrical power from container before removing components.
Failure to observe this warning may cause death or serious injury to personnel.

1. Disconnect container power.
2. Open circuit breaker access panel and remove ten screws and four outer panel covers (1).
3. Remove four outside corner screws from inner panel.
4. Locate appropriate circuit breaker.

NOTE

Tag all wires for reconnection.

5. Disconnect wires from the circuit breaker. Pull CB from center of control panel to remove.
6. Remove circuit breaker.

TM 9-4910-783-13&P

b. INSTALLATION

1. Check power source to ensure it is disconnected from container.
2. Reconnect wires to circuit breaker.
3. Replace circuit breaker.
4. Replace inner panel cover with four screws.
5. Replace four outer panel covers and secure with ten screws and close access panel.
6. Reconnect container power.

CIRCUIT BREAKER PANEL

a. REMOVAL

1. Disconnect container electrical power.
2. Open circuit breaker panel door.
3. Set all circuit breakers and switches to OFF position.
4. Remove three conduit nuts (1) on left side of circuit breaker box (Fig. 4-32).

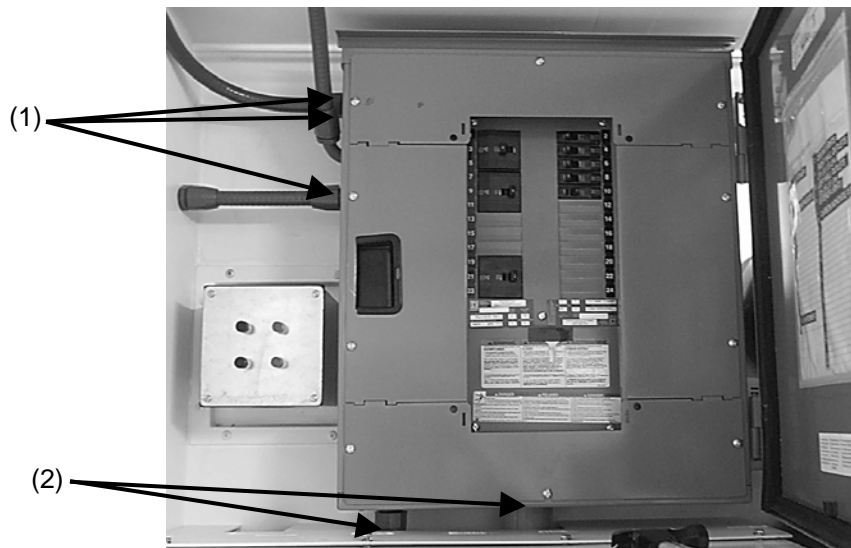

Figure 4-32. Front view of circuit breaker box and communication panel.

5. Remove ten screws and four outside panels.

TM 9-4910-783-13&P

a. REMOVAL (cont)

6. Loosen five captive screws.
7. Remove computer cabinet (WP 0025 00).
8. Remove two conduit nuts (2) from bottom of circuit breaker box.
9. Remove rivets (WP 0037 00) and separate circuit breaker panel assembly and spacer from RH sidewall panel.

b. DISASSEMBLY

1. Tag and disconnect wires from circuit breakers.
2. Remove circuit breakers from circuit breaker box.
3. If circuit breaker panel is being replaced, remove conduit connectors.

c. CLEANING, INSPECTION

NOTE

Do not use water to clean circuit breaker panel assembly.

1. Clean circuit breaker panel and component surfaces.
2. Inspect mounting surfaces for corrosion and damage.
3. Inspect for damaged circuit breakers.
4. Inspect panel wiring for cracks, tears, burns, or other damage.
5. Inspect for and replace if necessary:
 - a. Missing or damaged components.
 - b. Corrosion or paint damage (WP 0046 00).

d. REPAIR

1. Repair corrosion or paint damage (WP 0046 00).
2. Replace damaged circuit breakers.
3. Repair or replace damaged wiring.

TM 9-4910-783-13&P

e. ASSEMBLY

1. Install conduit connectors if applicable.
2. Install circuit breakers in circuit breaker box.
3. Connect wires to circuit breakers.
4. Position panel board over circuit breakers in circuit breaker box and secure.
5. Position circuit breaker panel cover against circuit breaker box and secure tightening captive screws.
6. Close circuit breaker panel door.

f. INSTALLATION

1. Position spacers and circuit breaker panel box against RH sidewall panel and secure with blind rivets.
2. Replace two conduit nuts on underside of circuit breaker box.
3. Replace computer cabinet (WP 0025 00).
4. Install circuit breakers in circuit breaker box.
5. Connect wires to circuit breakers.
6. Position panel board over circuit breakers in circuit breaker box and secure.
7. Position circuit breaker panel cover against circuit breaker box and secure by tightening captive screws.
8. Replace three conduit nuts on left side of circuit breaker box.
9. Replace four outside panels and secure with ten screws.
10. Close circuit breaker panel door.

END OF TASK

TM 9-4910-783-13&P

THIS TASK COVERS: a. Removal b. Disassembly
c. Cleaning, Inspection d. Repair e. Installation

INITIAL SETUP:

Tools and Special Tools:
Base Tools
GMTK

References:

Materials/Parts:

Equipment Conditions:
All switches and circuit breakers placed in
OFF position, power off

Personnel Required: 1

a. REMOVAL

WARNING



Disconnect all power sources from power input receptacle assembly before removing.

1. Disconnect site power.
2. Move computer cabinet (WP 0025 00) out of way of Power Input Receptacle.
3. Inside container, remove outer screws (1), lock washers and washers, and carefully lift cover assembly (2) away from RH sidewall panel as far as it will go (Fig. 4-33). Discard lock washers.

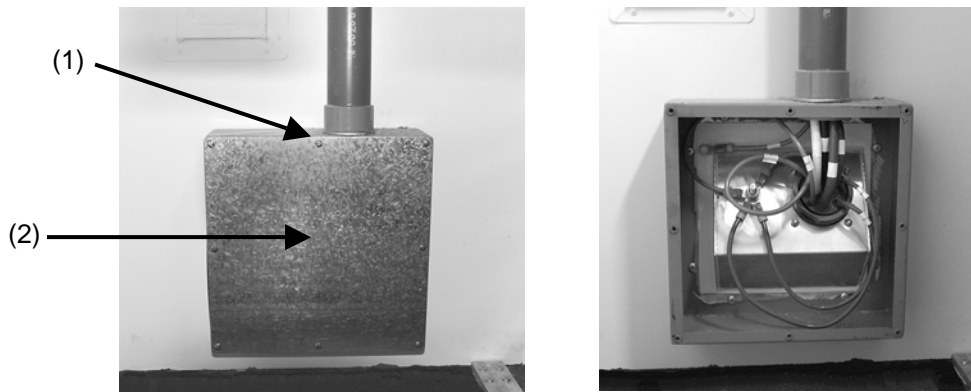

Figure 4-33. Power Input Receptacle on inside RH sidewall panel.

TM 9-4910-783-13&P

a. REMOVAL (cont)

NOTE

Tag all wires for reconnection.

4. Using channel lock pliers (WP 0058 00, SATS Base Tool Component List), remove retaining nut (1) (Fig. 4-34).

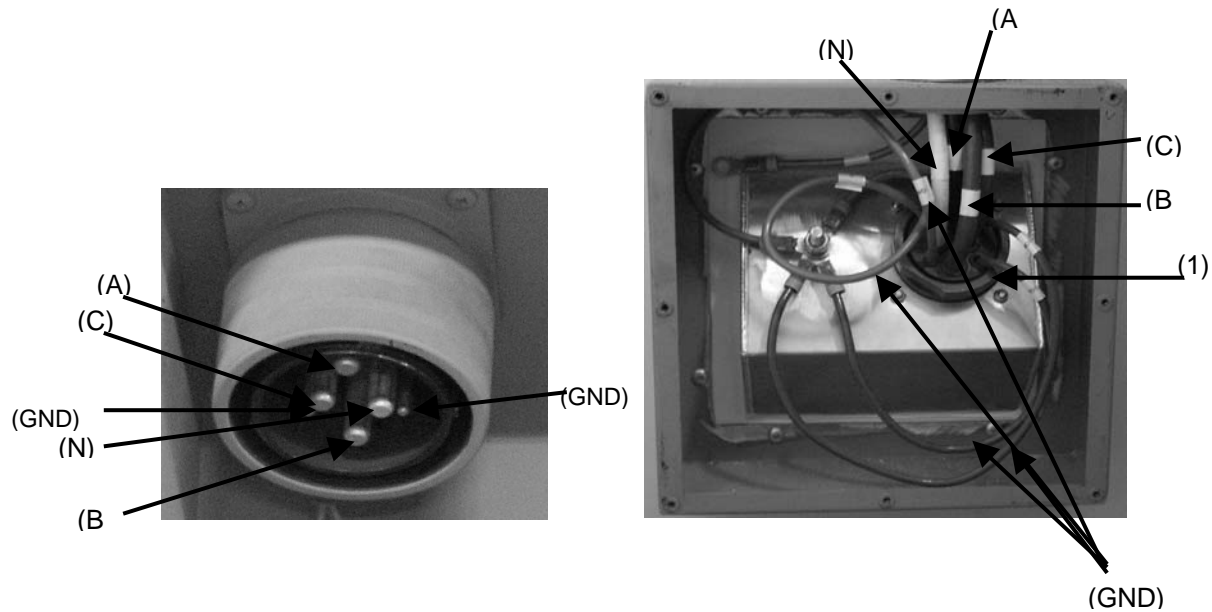

Figure 4-34. Power Input Receptacle front and rear view.

5. Carefully remove wires and center section of connector as one assembly.
6. Remove receptacle and gasket from panel.
7. Remove nuts, lock washers, washers, terminal lug, and threaded stud from panel. Discard lock washers.

TM 9-4910-783-13&P

a. REMOVAL (cont)

8. Outside container, drill out rivets (1) (WP 0037 00) and remove Power Input Receptacle assembly from RH sidewall panel.

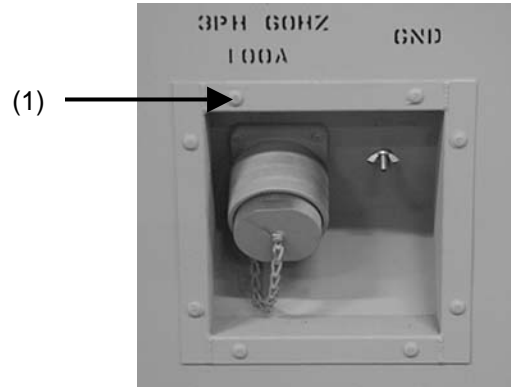

Figure 4-35. External view of Power Input Receptacle.

b. DISASSEMBLY

1. Remove screws, lock washers, receptacle covers, nuts, and washers. Discard lock washers.
2. Remove receptacle from panel.
3. Remove nuts, lock washers, washers, terminal lug, and threaded stud from panel. Discard lock washers.

c. CLEANING, INSPECTION

1. Clean Power Input Receptacle and component surfaces.
2. Inspect mounting surfaces for corrosion and damage.
3. Inspect for and replace if necessary:
 - a. Missing or damaged components.
 - b. Corrosion or paint damage.

d. REPAIR

1. Replace damaged receptacle, terminal, or threaded stud.
2. Repair corrosion or paint damage (WP 0046 00).

e. ASSEMBLY

1. Install threaded stud, terminal lug, three washers, three new lock washers, and four nuts in panel.

TM 9-4910-783-13&P

e. ASSEMBLY (cont)

2. Install receptacle and gasket.
3. Reinstall center section of connector.
4. Tighten retaining nut.

f. INSTALLATION

Terminals/Connectors

1. Install threaded stud, terminal lug, washers, new lock washers, and nuts in panel.
2. Inside container, position cover assembly against RH sidewall panel and secure with washers, new lock washers, and screws.

Receptacles

3. Install gasket, receptacle, nuts, receptacle cover, new lock washers, and screws in panel.
4. Install center section of connector. Tighten retaining nut.
5. Inside container, position cover assembly against RH sidewall panel and secure with washers, new lock washers, and screws.
6. Position Power Input Receptacle assembly against outside of RH sidewall panel and secure with rivets.
7. Position cover of assembly against inside of RH sidewall panel and secure with screws, new lock washers, and washers.
8. Reconnect electrical power to service entrance receptacle.
9. Move computer cabinet to original position (WP 0025 00).

END OF TASK

TM 9-4910-783-13&P

THIS TASK COVERS:

- a. Removal b. Installation

INITIAL SETUP:

Tools and Special Tools:

Base Tools
GMTK

References:

Materials/Parts:

Equipment Conditions:

All switches and circuit breakers placed in
OFF position, power off

Personnel Required: 2

a. REMOVAL

1. Remove two screws and open panel cover on outside RH sidewall communication panel.
2. Loosen hardware holding eight connectors (1) (Fig.4-36).

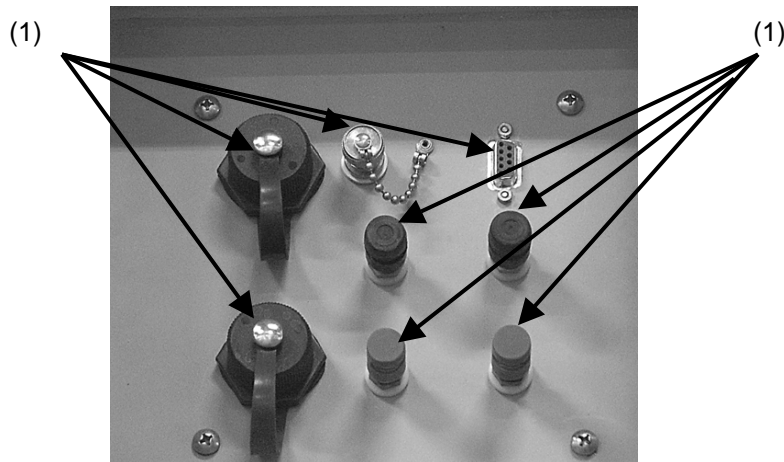

Figure 4-36. Communication panel.

3. Remove four screws and cover from panel on inside RH sidewall communication panel.
4. Loosen hardware holding connectors.
5. Remove wire on each of the four Bayonet Nut Connectors (BNCs).
6. Remove connectors.

TM 9-4910-783-13&P

b. INSTALLATION

NOTE

Some connectors must be installed externally.

1. Insert connectors.
2. Attach wire to each of four BNC connectors.
3. Attach and tighten mounting hardware on inside and outside communication panel.
4. Replace panel covers.
5. Insert and tighten panel cover screws.

END OF TASK

TM 9-4910-783-13&P

UTILITY STEP REMOVAL AND INSTALLATION

0030 00

THIS TASK COVERS:

a. Removal b. Installation

INITIAL SETUP:

Tools and Special Tools:

Base Tools
GMTK

References:

Materials/Parts:

Equipment Conditions:

All switches and circuit breakers placed in ON position, power on

Personnel Required: 1

a. REMOVAL

Remove two 3/8" bolts and two lock washers and folding utility step (1) from external personnel end wall (Fig. 4-37). Discard lock washers.

b. INSTALLATION

Install folding utility step (1) onto external personnel end wall and secure with two 3/8" bolts (torque to 30 ft-lb) and two new lock washers (Fig. 4-37).

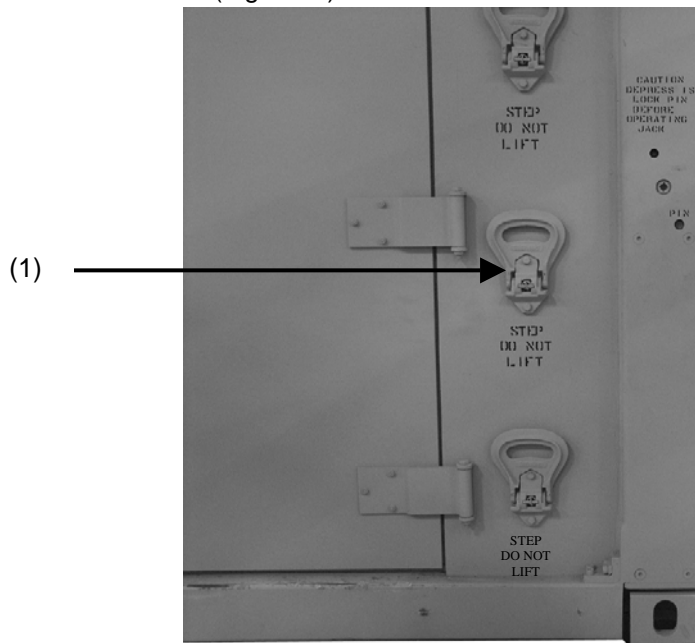

Figure 4-37. Folding steps on personnel end wall.

END OF TASK

TM 9-4910-783-13&P

BLACKOUT LIGHT ASSEMBLY REMOVAL, REPAIR, AND INSTALLATION

0031 00

THIS TASK COVERS:

a. Removal b. Cleaning, Inspection c. Repair d. Installation

INITIAL SETUP:

Tools and Special Tools:

Base Tools
GMTK

References:

Materials/Parts:

Equipment Conditions:

All switches and circuit breakers placed in OFF position, power off

Personnel Required: 1

WARNING



This fixture is dangerous if incandescent circuit breaker contains voltage that is contacted. Before replacing light assembly, set all breakers and switches to OFF Position.

a. REMOVAL

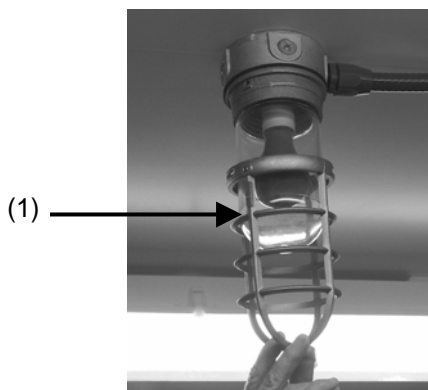

Figure 4-38. Blackout light guard removal.

1. Loosen set screws and remove guard (1) (Fig. 4-38).

TM 9-4910-783-13&P

a. REMOVAL (cont)

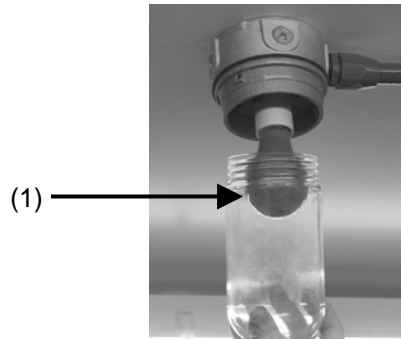

Figure 4-39. Blackout light globe removal.

2. Unscrew globe (1) and remove from socket adapter (Fig. 4-39).
3. Unscrew bulb from light fixture.
4. Slide and separate socket adapter from surface box.
5. Remove the two blind rivets (WP 0037 00) surface box.

NOTE

Tag wires for reconnection.

6. Disconnect wires from rear of light fixture.
7. Disconnect conduit from fixture.
8. Remove conduit adapter if applicable.

b. CLEANING, INSPECTION

1. Clean blackout light assembly and component systems.
2. Inspect mounting surfaces for corrosion and damage.
3. Inspect for and replace if necessary:
 - a. Missing or damaged components.
 - b. Corrosion or paint damage.

c. REPAIR

Repair corrosion or paint damage (WP 0046 00).

TM 9-4910-783-13&P

d. INSTALLATION

1. Connect conduit adapter if applicable to fixture.
2. Position light fixture near light fixture adapter and connect wires.
3. Connect wires to light fixtures.
4. Connect conduit connector to conduit adapter.
5. Secure surface box into place with self-tapping screws.
6. Slide socket adapter into place on surface box.
7. Install bulb.
8. Screw globe into place.
9. Replace guard and tighten setscrews.

END OF TASK

TM 9-4910-783-13&P

THIS TASK COVERS:	a. Removal	b. Disassembly	
c. Cleaning, Inspection	d. Repair	e. Assembly	f. Installation
INITIAL SETUP:			
Tools and Special Tools: Base Tools GMTK	References:		
Materials/Parts:	Equipment Conditions: All switches and circuit breakers placed in OFF position, power off		
Personnel Required: 1			

WARNING



This fixture contains voltage that is dangerous if contacted. Before replacing fixed roof area ceiling light, set all circuit breakers and switches to OFF position.

a. REMOVAL

NOTE

Tag wires for reconnection.

1. Remove white retaining clips (1) and lens (2) from area ceiling light (Fig. 4-40).

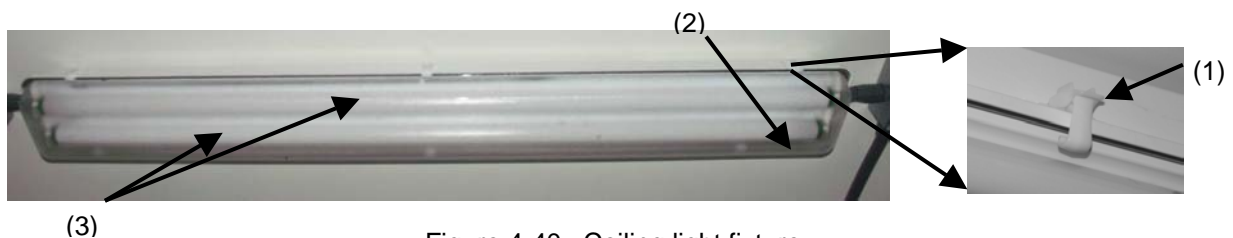

Figure 4-40. Ceiling light fixture.

2. Remove tube locks from ends of fluorescent tubes (3) and remove lamps.

TM 9-4910-783-13&P

a. REMOVAL (cont)

3. Unsnap metal plate (1) and remove (Fig. 4-41).



Figure 4-41. Ceiling light with metal cover exposed.

4. Loosen conduit connector(s) (1) from conduit adapter (Fig. 4-42) and remove wire nuts from inside fixture.

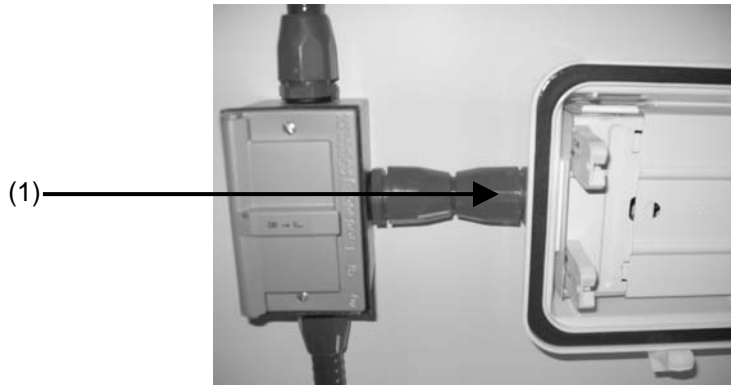
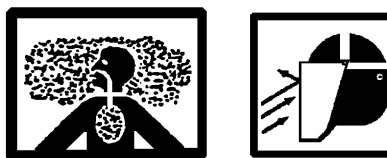

Figure 4-42. Conduit attached to ceiling light fixture.

5. Remove cap screws and remove fixture while guiding wire through conduit adapter.
6. Remove conduit adapter if applicable.

b. DISASSEMBLY

WARNING



In the event of lamp breakage, care must be taken in removal of broken glass fragments and dust that may be dispersed within fixture. Inhalation of dust could cause serious injury. Ensure area is well ventilated.

Cleanup requires special care due to mercury droplet proliferation. Contact your supervisor for disposal guidance.

TM 9-4910-783-13&P

b. DISASSEMBLY (cont)

1. Remove retaining clips (1) and lens (2) from fixture (Fig. 4-40).

CAUTION

When removing end caps, hold safety tube level to prevent fluorescent tube from accidentally sliding out and dropping.

2. Remove tube locks from both ends of fluorescent lamps (3) (Fig. 4-40).
3. Remove two fluorescent lamps by rotating and sliding out of light frame.
4. Unsnap metal cover and remove.

NOTE

Tag all wires for reconnection.

5. Remove wire nuts and separate wires between ballast and contacts at opposite end of light frame.
6. Remove bolt holding ballast (1) in place and remove ballast and light contacts (Fig. 4-43).



Figure 4-43. Ballast in ceiling light fixture.

7. Remove conduit adapter if applicable.

c. CLEANING, INSPECTION

1. Clean ceiling light and component surfaces.
2. Inspect mounting surfaces for corrosion and damage.
3. Inspect for and replace if necessary:
 - a. Missing or damaged components.
 - b. Corrosion or paint damage.

TM 9-4910-783-13&P

d. REPAIR

Repair corrosion or paint damage (WP 0046 00).

e. ASSEMBLY

1. Install conduit adapters if applicable.
2. Position ballast in light frame and secure with bolt.
3. Position light contacts in place.
4. Install metal cover by snapping in place.
5. Install fluorescent lamps by sliding in and rotating.
6. Install tube locks.
7. Attach lens with white plastic retaining clips.

f. INSTALLATION

1. Attach fixture to ceiling with cap screws.
2. Guide wire through conduit adapter. Tighten conduit connector to conduit adapter. Connect wire.
3. Attach ballast and light contacts.
4. Replace metal cover by snapping in place.
5. Install fluorescent lamps by sliding in and rotating.
6. Install tube locks.
7. Attach lens with white plastic retaining clips.

END OF TASK

TM 9-4910-783-13&P

INTERNAL RECEPTACLE OUTLETS REMOVAL, REPAIR, AND INSTALLATION

0033 00

THIS TASK COVERS:	a. Removal	b. Disassembly
c. Cleaning, Inspection	d. Repair	e. Assembly f. Installation

INITIAL SETUP:

Tools and Special Tools:
Base Tools
GMTK

References:

Materials/Parts:

Equipment Conditions:
All switches and circuit breakers placed in
OFF position, power off

Personnel Required: 1

WARNING



Remove all electrical power from circuits before removing cable and receptacle assemblies.

a. REMOVAL

1. Set all circuit breakers to the OFF position.
2. Remove screws (1) and duplex receptacle cover (Fig. 4-44).

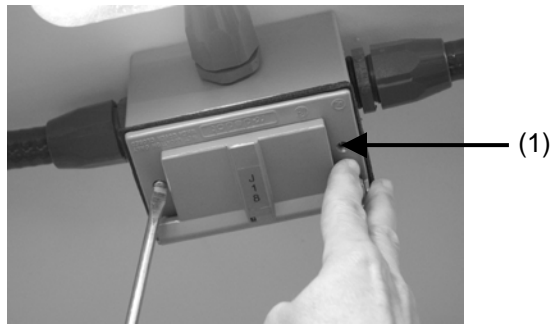

Figure 4-44. Internal receptacle outlet box.

TM 9-4910-783-13&P

a. REMOVAL (cont)

3. Loosen captive screws (1) and move duplex receptacle away from outlet boxes as far as they will go (Fig. 4-45).

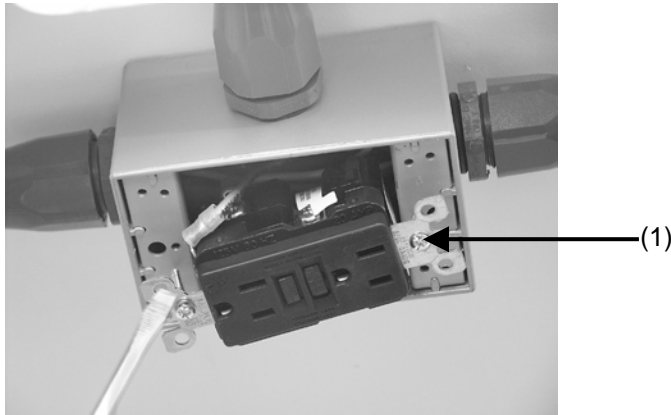

Figure 4-45. Duplex receptacle.

NOTE

Tag wires for reconnection.

4. Disconnect wires from rear of duplex.

b. DISASSEMBLY

1. Remove screws and duplex covers.
2. Loosen captive screws and move duplex receptacles away from junction box as far as they will go.

NOTE

Tag wires for reconnection.

3. Remove terminals and disconnect wires from rear of receptacles, where applicable.

c. CLEANING, INSPECTION

1. Clean cable and receptacle assembly and component surfaces.
2. Inspect mounting surfaces for corrosion and damage.
3. Inspect for and replace if necessary:
 - a. Missing or damaged components.
 - b. Corrosion or paint damage.

TM 9-4910-783-13&P

d. REPAIR

1. Replace damaged duplex receptacles.
2. Repair corrosion or paint damage (WP 0046 00).

e. ASSEMBLY

1. Connect wires to receptacle and terminals, where applicable.
2. Position receptacles on junction box and install screws.
3. Position covers on duplex receptacles and install screws.

f. INSTALLATION

1. Position duplex receptacles near outlet boxes and connect wires.
2. Position duplex receptacles on outlet boxes and tighten captive screws.
3. Position duplex receptacle covers on outlet boxes and install screws.

END OF TASK

TM 9-4910-783-13&P

WALL SWITCH REMOVAL AND INSTALLATION

0034 00

THIS TASK COVERS:

- a. Removal b. Installation

INITIAL SETUP:

Tools and Special Tools:

Base Tools
GMTK

References:

Materials/Parts:

Equipment Conditions:

All switches and circuit breakers placed in OFF position, power off

Personnel Required: 1

a. REMOVAL

1. Set all circuit breakers to OFF position.
2. Remove two screws (1) and switch cover (Fig. 4-46).

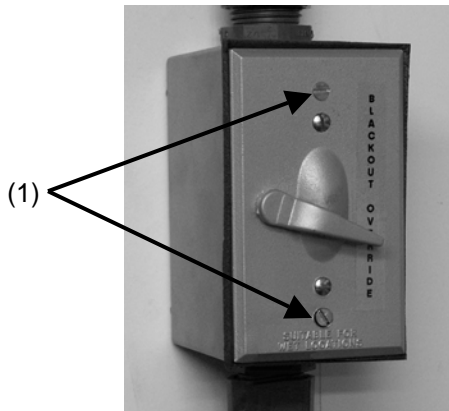

Figure 4-46. Wall switch.

3. Remove two screws and carefully pull wall switch out of switch box as far as it will go.

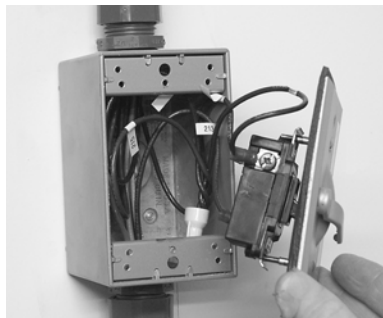

Figure 4-47. Switch pulled out of switch box.

TM 9-4910-783-13&P

a. REMOVAL (cont)

NOTE

Tag all wires for reconnection.

4. Disconnect wires from switch.

b. INSTALLATION

1. Position switch near switch box and connect wires to rear of switch.
2. Position switch in switch box and secure with two screws.
3. Position switch cover against switch box and secure with two screws.

END OF TASK

TM 9-4910-783-13&P

LIMIT SWITCH REMOVAL, REPAIR, INSTALLATION, AND ADJUSTMENT

0035 00

THIS TASK COVERS:

a. Removal b. Cleaning, Inspection c. Repair d. Installation e. Adjustment

INITIAL SETUP:

Tools and Special Tools:
Base Tools
GMTK

References:

Materials/Parts:

Equipment Conditions:
All switches and circuit breakers placed in
OFF position, power off

Personnel Required: 1

a. REMOVAL

NOTE

Tag wires for reconnection.

1. Disconnect power to Blackout Switch.
2. Loosen captive screws and remove limit switch cover (1) (Fig. 4-48).

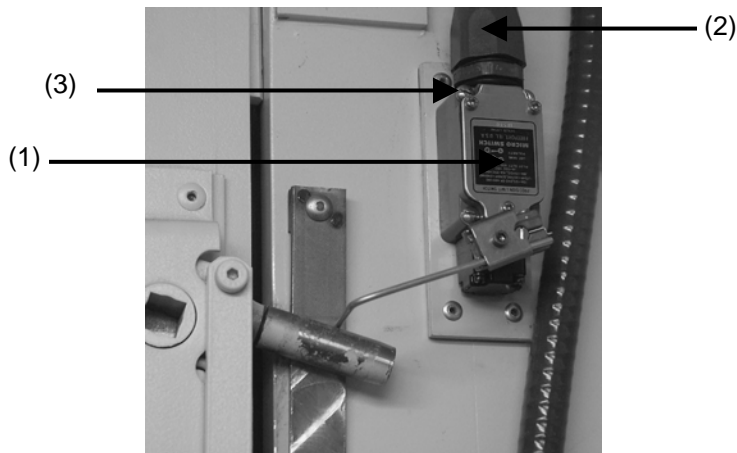

Figure 4-48. Limit switch.

3. Remove conduit connector (2) to blackout limit switch.

NOTE

Tag all wires for reconnection.

4. Disconnect three wires plus one ground wire inside limit switch.

TM 9-4910-783-13&P

a. REMOVAL (cont)

5. Remove screws (3) holding limit switch to limit switch mounting plate (Fig. 4-48).
6. Remove conduit adaptor from blackout limit switch.

b. CLEANING, INSPECTION

1. Clean limit switch and component surfaces.
2. Inspect mounting surfaces for corrosion and damage.
3. Inspect for and replace if necessary:
 - a. Missing or damaged components.
 - b. Corrosion or paint damage.

c. REPAIR

Repair corrosion or paint damage (WP 0046 00).

d. INSTALLATION

1. Install conduit adaptor.
2. Secure limit switch to limit switch mounting plate with screws.
3. Connect three wires plus one ground wire inside limit switch.
4. Position limit switch cover on limit switch and tighten captive screws.
5. Reconnect conduit connector.

TM 9-4910-783-13&P

e. ADJUSTMENT

There are three possible adjustments that can be made on the limit switch.

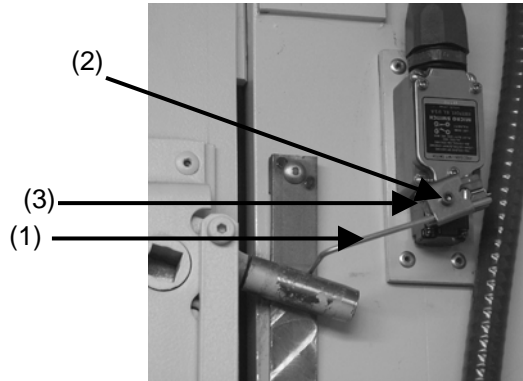

Figure 4-49. Limit switch.

1. Bend limit switch arm (1) towards or away from the end wall panel (Fig. 4-49).
2. Loosen set screw (2) on collar and slide limit switch arm (1) in or out of collar.
3. Loosen nut (3) and rotate collar with limit switch arm (1) up or down.

END OF TASK

TM 9-4910-783-13&P

WIRING REMOVAL, REPAIR, AND INSTALLATION

0036 00

THIS TASK COVERS:

a. Removal b. Cleaning/Inspection c. Repair d. Installation

INITIAL SETUP:

Tools and Special Tools:

Base Tools
GMTK

References:

Materials/Parts:

Wire

Equipment Conditions:

All switches and circuit breakers placed in
OFF position, power off

Personnel Required: 1

WARNING



Wiring contains voltage that is dangerous if contacted. Before replacing wiring, make sure all circuit breakers and switches are set to OFF position.

a. REMOVAL (as required per no continuity)

1. Open circuit breaker panel door.
2. Remove 10 screws and lift four outer panel boards from circuit breaker box.
3. Remove remaining five screws and inner panel.
4. Loosen captive screws and remove conduit outlet cover from conduit outlet body.
5. Remove area ceiling lights and blackout lights from ceiling (WP 0031 00, Blackout Light and WP 0032 00, Ceiling Light).

NOTE

Tag wires for reconnection.

6. Disconnect wires in each of three area ceiling lights.
7. Remove screws and receptacle covers from outlet boxes and switch covers from switches.

TM 9-4910-783-13&P

a. REMOVAL (cont)

NOTE

Tag wires for reconnection.

8. Disconnect wires at rear of receptacles.
9. Disconnect conduit locknuts at each of three ceiling lights.
10. Disconnect conduit locknut at circuit breaker box.
11. Disconnect conduit locknut at junction box above ECU.
12. Disconnect wires from rear of duplex receptacles and pull wire through electrical conduits to remove.

c. CLEANING, INSPECTION

1. Inspect mounting surfaces for corrosion and damage.
2. Inspect for and replace if necessary:
 - a. Missing or damaged components.
 - b. Corrosion or paint damage.

d. REPAIR

1. Replace damaged wiring.
2. Repair corrosion or paint damage (WP 0046 00).

e. INSTALLATION

1. Pull wires through electrical conduits.
2. Connect wires to rear of duplex receptacles, ceiling lights, blackout lights, and switches.
3. Position duplex receptacles in outlet boxes and secure by tightening captive screws.
4. Attach duplex covers to duplex receptacles with screws.
5. Position panel board over circuit breakers in circuit breaker box and secure.
6. Position circuit breaker panel cover against circuit breaker box and secure by tightening captive screws.
7. Close circuit breaker panel doors.

END OF TASK

TM 9-4910-783-13&P

RIVET REMOVAL AND INSTALLATION

0037 00

THIS TASK COVERS:

a. Removal b. Installation

INITIAL SETUP:

Tools and Special Tools:

Base Tools
GMTK

References:

Materials/Parts:

Sealant (Item 16, WP 0057 00)

Equipment Conditions:

All switches and circuit breakers placed in
OFF position, power off

Personnel Required: 1

a. REMOVAL

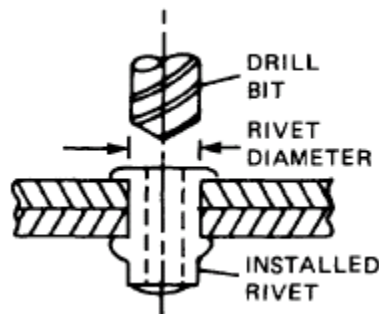
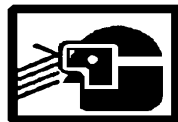

Figure 4-50. Illustration of installed rivet.

WARNING



Wear safety goggles for eye protection from flying metal chips.

1. Punch out center of rivet.
2. Select drill bit (WP 0058 00, SATS Base Tool Component List) the same diameter as shank of installed blind rivet.
3. Install selected drill bit in chuck of drill (WP 0058 00, SATS Base Tool Component List).
4. Hold drill perpendicular to surface to prevent enlargement or damage to existing hole.

TM 9-4910-783-13&P

a. REMOVAL (cont)

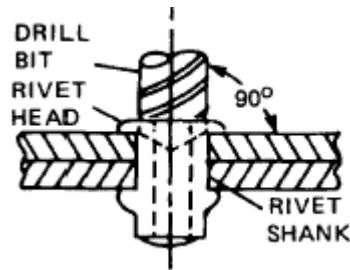

Figure 4-51. Installed Rivet.

5. Drill through center of rivet just deep enough to sever rivet head from shank (Fig. 4-51).
6. Remove remainder of rivet with a pin punch (WP 0058 00, SATS Base Tool Component List).
7. Deburr rivet hole.

b. INSTALLATION

NOTE

When installing a rivet in the floor or wall, a sealant should be added to rivet prior to installation.

1. Select proper diameter and length of rivet.
2. Select appropriate nose piece for hand riveter (WP 0058, SATS Base Tool Component List) and install nose piece (Fig.4-52).

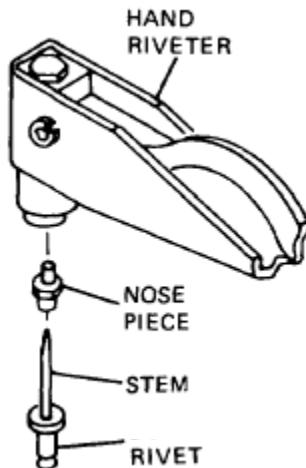

Figure 4-52. Hand riveter with nose piece.

TM 9-4910-783-13&P

b. INSTALLATION (cont)

3. Wet rivet with sealant (Item 16, WP 0057 00) and insert rivet in hole.
4. Holding hand riveter at right angle to work, install on blind rivet stem.
5. Push against work with just enough force to firmly seat rivet and prevent part separation (Fig. 4-53).
6. Actuate and pull rivet until stem breaks.
7. Trim broken stem flush with rivet head.
8. Firmly press on installed rivet to check tightness of installation.
9. Remove and replace in accordance with procedure if installation is unacceptable.

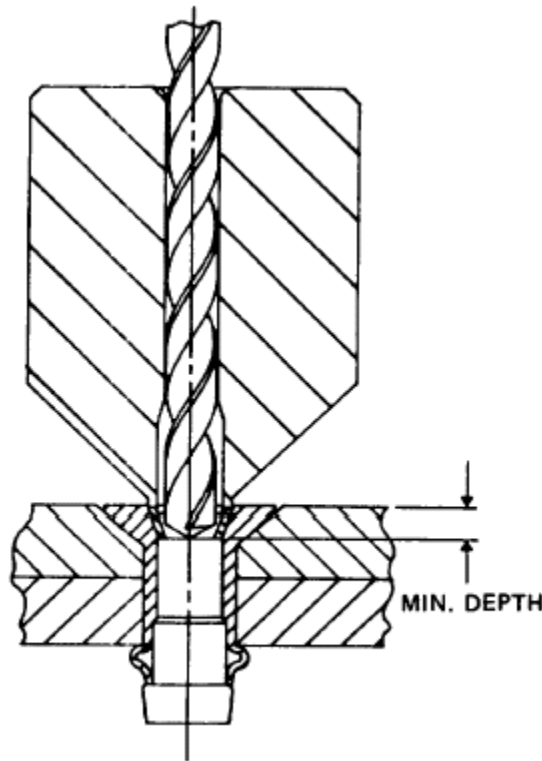

Figure 4-53. Firmly seating rivet in place.

END OF TASK

TM 9-4910-783-13&P

DOOR GASKET REMOVAL AND INSTALLATION

0038 00

THIS TASK COVERS:

- a. Removal b. Installation

INITIAL SETUP:

Tools and Special Tools:

Base Tools
GMTK

References:

Materials/Parts:

Acetone/Cleaning Solvent
Permabond 268 (Item 18, WP 0057 00)

Equipment Conditions:

All switches and circuit breakers placed in
ON position, power on

Personnel Required: 1

a. REMOVAL

1. Remove old door gasket (1) from exterior doorjambs and discard (Fig. 4-54).

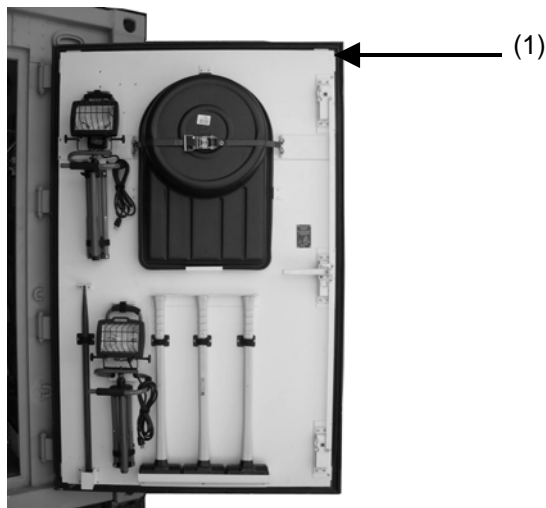

Figure 4-54. Door assembly

2. Using a scraper, remove residual gasket/adhesive from doorjambs.
3. Abrade surface of aluminum.
4. Clean aluminum surface with acetone or equivalent cleaning solvent.

b. INSTALLATION

1. Take seal gasket and position against container doorjambs and mark location of top left and top right corners on outside edge of gasket.

TM 9-4910-783-13&P

b. INSTALLATION (cont)

WARNING

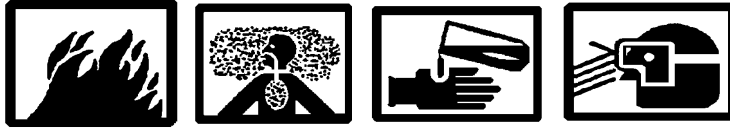

Sealing Compound

Permabond 268 is flammable and will bond to eyelids, skin, and mouth. Skin and eye protection are required. Avoid repeated/prolonged contact. Good, general ventilation is normally adequate.

Cloths used to wipe up spills may cause rapid polymerization that could generate sufficient heat to ignite the cloth. Immediately soak cloth with water to polymerize the adhesive. Combustion may release noxious or toxic vapors. Use polyethylene gloves. Do not wear rubber or cloth gloves.

No attempt should be made to remove material from skin or to remove contaminated clothing, as the bonded skin can easily be torn. Wash with large volumes of soap and water while flexing bonded skin parts. This procedure will slowly release bonded areas.

Do not mechanically remove cured adhesive or attempt to pull skin apart.

2. Apply Permabond 268 (Item 18, WP 0057 00) seal adhesive to doorjambs in area of seal replacement.

NOTE

The balance of gasket material must be kept away from doorjambs until its application can be addressed.

3. Starting at top left corner, apply gasket to doorjamb and work your way to top right corner and then down to the bottom, taking care to position gasket uniformly on jamb.

CAUTION

Take care to keep adhesive from getting on skin or clothes. Dispose of properly.

4. Remove excess seal adhesive from doorjamb. Check to make sure that gasket is installed flat against jambs in all areas. If necessary, use a flat tool to smooth gasket against jamb.
5. Leave gasket undisturbed for at least 24 hours to allow adhesive to cure properly.

END OF TASK

TM 9-4910-783-13&P

MAIN DOOR REMOVAL AND INSTALLATION

0039 00

THIS TASK COVERS:

- a. Removal b. Installation

INITIAL SETUP:

Tools and Special Tools:

Base Tools
GMTK

References:

Materials/Parts:

Equipment Conditions:

All switches and circuit breakers placed in ON position, power on
Container level according to inclinometer readings on outside of container

Personnel Required: 8

a. REMOVAL

WARNING



Door weighs 300 lbs., requires eight-person lift.

Remove hinge pin, nut, and two washers from hinge butt (1) on each of four locations. Save hinge pin, nut, and two washers for reuse (Fig. 4-55).

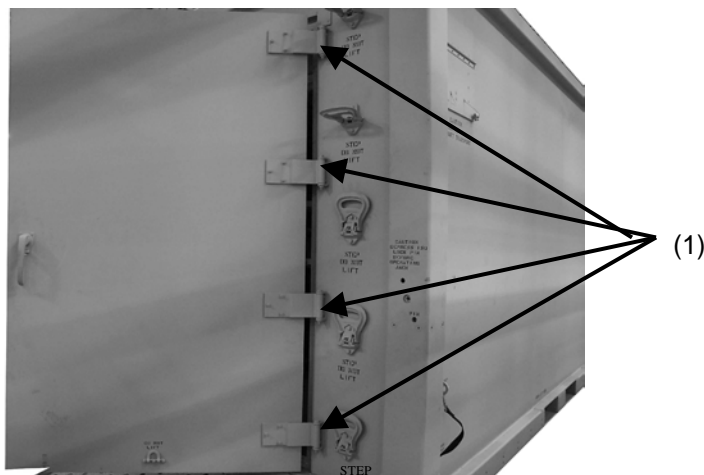

Figure 4-55. Personnel door.

TM 9-4910-783-13&P

a. REMOVAL (cont)



Figure 4-56. Main door hinges and utility steps.

b. INSTALLATION

1. Install and align replacement door with hinge strap (1) (Fig. 4-56) on hinge butt and secure with hinge pin, nut, and washers previously removed. After all four hinge pins are installed, tighten nuts.
2. Check main door for proper operation of hardware and closure of door against jamb seals.

END OF TASK

TM 9-4910-783-13&P

THIS TASK COVERS:

Repair

INITIAL SETUP:

Tools and Special Tools:

Base Tools
GMTK
Putty Knife

References:

Materials/Parts:

Emery Paper
Dowclene EC (6K748) (Item 19, WP 0057 00)
Dent Filler
Devcon F (Item 20, WP 0057 00)
Epoxy Primer (Item 7, WP 0057 00)
CARC Paint

Equipment Conditions:

All switches and circuit breakers placed in ON position, power on

Personnel Required: 1

REPAIR

The container top, floor and side panels are constructed of aluminum-bonded material. The following procedures must be used to repair dents or depressions (see Figure 4-57). If face sheet is not punctured, proceed as follows:

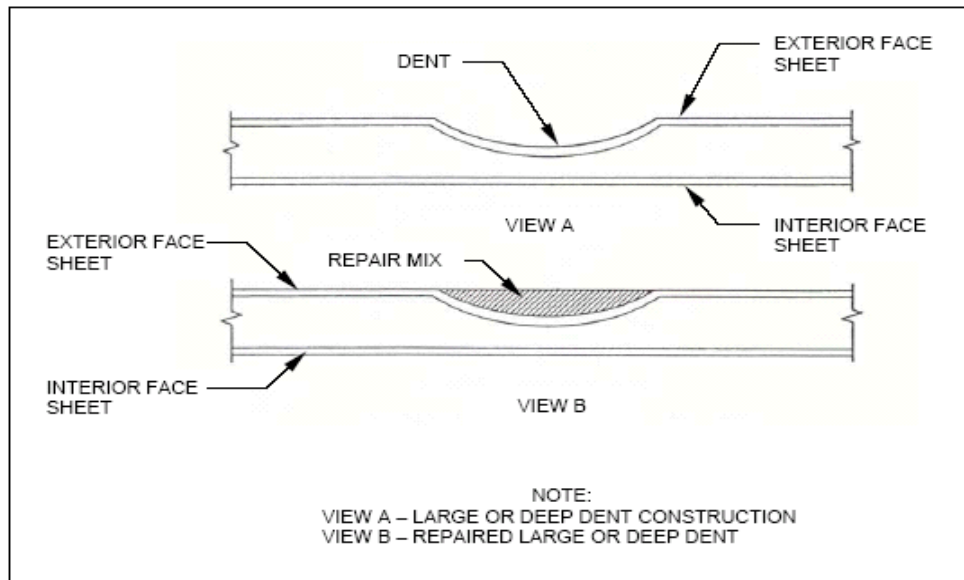

Figure 4-57. Typical Dents or Depressions

1. Sand damaged area with emery paper to remove all traces of paint.

TM 9-4910-783-13&P

REPAIR (cont)

WARNING



Cleaning Solvent

Dowclene EC (6K748) is flammable and harmful to eyes, skin, and breathing passages. Observe all fire precautions. Use only with adequate ventilation and with approved personal protective equipment.

2. Wipe surface with cloth dampened in Dowclene EC (6K748) (Item 19, WP 0057 00) and immediately wipe solvent from surface with clean dry cloth.
3. Mix small quantity of dent filler, Devcon F (Item 20, WP 0057 00).
4. Fill in damaged area with dent filler using spatula or putty knife.
5. Allow dent filler to cure fully according to manufacturing instructions.
6. Sand surface of cured dent filler to conform to surrounding area.
7. After repair, touch up with epoxy primer (Item 7, WP 0057 00) and CARC paint as required.

END OF TASK

TM 9-4910-783-13&P

REPAIR OF PUNCTURE LESS THAN ½ INCH (12.70 mm)-
ALUMINUM BONDED MATERIAL

0041 00

THIS TASK COVERS:

Repair

INITIAL SETUP:

Tools and Special Tools:

Base Tools
GMTK

References:

Materials/Parts:

Devcon F (Item 20, WP 0057 00)
Dowclene EC (6K748) (Item 19, WP 0057 00)
EA9324 Adhesive (1JB33) (Item 21, WP 0057 00)
Aluminum Alloy Sheet Stock (6061T6) (QQ-A-250/11) (Item 22, WP 0057 00)
PRC 1422 B-2 Sealant (7D294) (Item 22, WP 0057 00)
Epoxy Primer (Item 7, WP 0057 00)
CARC Paint

Equipment Conditions:

All switches and circuit breakers placed in
ON position, power on

Container level according to inclinometer
readings on outside of container

Personnel Required: 1

REPAIR

The following procedures should be used to repair skin punctures with a diameter less than ½ inch (12.70mm) or a depth in core of less than ½ inch (12.70mm) (see Figure 4-58). Proceed as follows:

1. If a patch is not available, make patch as follows:
 - a. Cut patch from unpainted Aluminum Alloy Sheet Stock (6061T6) (QQ-A-250/11) (Item 2, WP 0057 00), 0.050 inch (1.27 mm) thick.
 - b. Make patch rectangular with width and length dimensions to be such as to extend a minimum of 1 inch (25.40 mm) beyond damage surface area.
2. Cut or file corners to 0.25-inch (6.35 mm) radius.

REPAIR (cont)

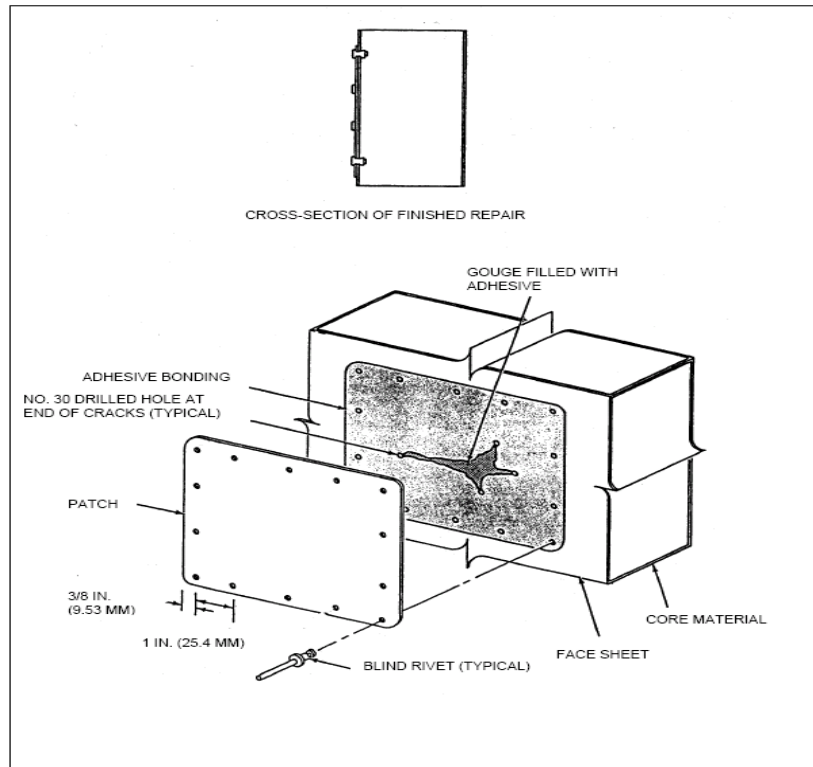

Figure 4-58. Typical repair procedure for punctures less than 1/2 inch (12.70 mm)

3. Position patch centered over damaged area and lightly scribe or mark outline of patch onto panel face.
4. Remove paint from panel face within marked outline. All traces of paint must be removed and sanded.
5. Layout rivet hole pattern around edge of patch as shown in Figure 4-58.
 - a. Use 3/8-inch (9.53 mm) edge distance and 1 inch (25.40 mm) spacing.
 - b. Drill holes using 1/8" drill bit.
6. Center patch over cutout panel.
7. Drill through panel face sheet using pre-drilled holes in patch as guide. Sheet fasteners may be used to secure patch temporarily in place while drilling. If sheet fasteners are not available, drill holes using 1/8" drill bit and insert 1/8-inch (3.18 mm) diameter rivet in each panel hole as drilled to keep patch from changing location or slipping. Do not pull or install rivets permanently.
8. Remove patch and remove all burrs from drilled holes.
9. Prepare bonding surface of panel face sheet for bonding by sanding until oxide film is removed and bright surface is exposed.

TM 9-4910-783-13&P

REPAIR OF PUNCTURE LESS THAN 1/2 INCH (12.70 mm)-
ALUMINUM BONDED MATERIAL

0041 00

REPAIR (cont)

NOTE

If the punctured or gouged area in the panel is surrounded by extended cracks, stop and drill all cracks using 1/8" drill bit (0.1285 inch (3.264 mm)) drill.

10. Fill cavity panel as shown in Figure 4-58 using dent filler, Devcon F (Item 20, WP 0057 00).
11. After dent filler material has hardened, sand material flush with panel face surface.

WARNING



Cleaning Solvent

Dowclene EC (6K748) is flammable and harmful to eyes, skin, and breathing passages. Observe all fire precautions. Use only with adequate ventilation and with approved personal protective equipment.

12. Wipe panel face sheet and patch surfaces with clean cloth soaked in Dowclene EC (6K748) (Item 19, WP 0057 00) and immediately wipe solvent from surface with clean cloth. Wear gloves to avoid contaminating surfaces with dirt, oil, or fingerprints.
13. Apply thin, even layer of EA9324 adhesive (IJB33) (Item 21, WP 0057 00) bonding surfaces of panel face and patch.
14. Position patch temporarily in place with 1/8-inch (3.18 mm) sheet fasteners.
15. Install 1/8-inch (3.18 mm) universal head blind rivets (closed end) in all drill holes.

WARNING



Cleaning Solvent

Dowclene EC (6K748) is flammable and harmful to eyes, skin, and breathing passages. Observe all fire precautions. Use only with adequate ventilation and with approved personal protective equipment.

TM 9-4910-783-13&P

REPAIR OF PUNCTURE LESS THAN ½ INCH (12.70 mm)-
ALUMINUM BONDED MATERIAL

0041 00

REPAIR (cont)

16. Remove any excess adhesive from outer surface of repair area by wiping with cloth dampened in Dowclene EC (6K748) (Item 19, WP 0057 00).

WARNING



Sealing Compound

PRC 1422 B-2 sealant (7D294) is flammable and harmful to eyes, skin, and breathing passages. Observe all fire precautions. Use only with adequate ventilation and with approved personal protective equipment.

17. Apply bead of sealant around patch using PRC 1422 B-2 sealant (7D294) (Item 22, WP 0057 00). Allow approximately 2 to 4 hours for sealant to cure.

18. After repair, touch up with epoxy primer (Item 7, WP 0057 00) and CARC paint as required.

END OF TASK

TM 9-4910-783-13&P

REPAIR OF FRACTURES LESS THAN 1-1/2 X 3 INCHES (38.10 X 76.20 mm)-
ALUMINUM BONDED MATERIAL

0042 00

THIS TASK COVERS:

Repair

INITIAL SETUP:

Tools and Special Tools:

Base Tools
GMTK

References:

Materials/Parts:

Dowclene EC (6K748) (Item 19, WP 0057 00)
Epoxy Resin (EA828) (Item 8, WP 0057 00)
Epoxy Primer (Item 7, WP 0057 00)
Diethylenetriamine Activator (O-D-1271) (Item 5, WP 0057 00)
CARC Paint
Aluminum Powder (MIL-A-82654)
(Item 23, WP 0057 00)

Equipment Conditions:

All switches and circuit breakers placed in
ON position, power on

Container level according to inclinometer
readings on outside of container

Personnel Required: 1

REPAIR

The following procedures should be used to repair skin fractures with an area of less than 1-1/2 x 3 inches (38.10 x 76.20 mm) (see Figure 4-59). Proceed as follows:

1. To rid the immediate damaged area of foreign material, grease, and dirt, brush area with a stiff wire brush.
2. Stop-drill all tears or cracks in the face skin using 1/8" drill bit.

TM 9-4910-783-13&P

REPAIR OF FRACTURES LESS THAN 1-1/2 X 3 INCHES (38.10 X 76.20 mm)-
ALUMINUM BONDED MATERIAL

0042 00

REPAIR (cont)

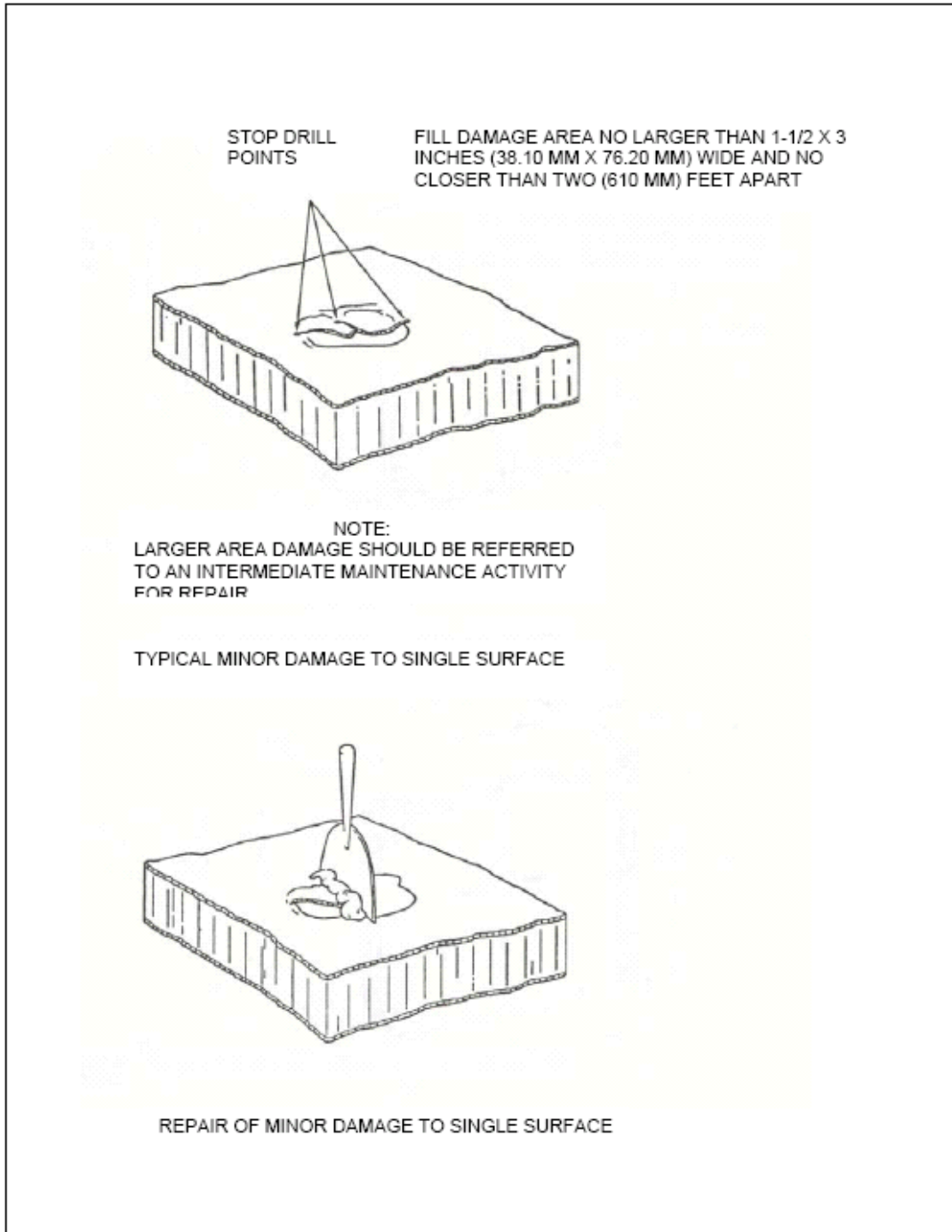

Figure 4-59. Typical repair procedure for face skin damage less than 1-1/2 x 3 inches (38.10 x 76.20 mm)

TM 9-4910-783-13&P

REPAIR OF FRACTURES LESS THAN 1-1/2 X 3 INCHES (38.10 X 76.20 mm)-
ALUMINUM BONDED MATERIAL

0042 00

REPAIR (cont)

- Clean damaged area with Dowclene (Item 19, WP 0057 00).

WARNING



Do not use plastic container for mixing. Heat generated by mixed material may result in melting of container and may cause burns. Mix the epoxy resin (EA828) and diethylenetriamine activator (O-D-1271) in a well ventilated area. The vapor produced is toxic. Avoid breathing vapors and avoid skin contact with the mixture. If the adhesive contacts the skin, flush area with warm water and soap.

- Mix epoxy resin (EA828) (Item 8, WP 0057 00) and diethylenetriamine activator (O-D-1271) in ratio of 100 parts of resin to seven parts of activator by weight. Add sufficient aluminum powder (MIL-A-82654) (Item 23, WP 0057 00) to form a thin paste.

NOTE

This paste will harden in 15 to 20 minutes at room temperature.

- Pour paste into damaged area. Do not overfill (See Figure 4-59).
- With the 1-1/2 inches (38.10 mm) wide spatula, smooth out paste in such a way as to create a level fill of the damaged area.
- Cure paste for 24 hours at room temperature.
- If necessary, sand and paint with epoxy primer (Item 7, WP 0057 00) and CARC paint as required.

END OF TASK

TM 9-4910-783-13&P

RIVNUT REPAIR

0043 00

THIS TASK COVERS:

Repair

INITIAL SETUP:

Tools and Special Tools:
Base Tools
GMTK

References:

Materials/Parts:

Equipment Conditions:
All switches and circuit breakers placed in
ON position, power on

Personnel Required: 1

REPAIR

1. Using a 3/8" drill (WP 0058 00, SATS Base Tool Component List), drill stripped threads from existing rivnuts.
2. Determine appropriate insert size to employ by utilizing Table 4-2, below.

Table 4-2. Drill bit selection

Insert Thread Size	NSN	Drill Bit
1/4 " 20 tpi	5325-01-525-3843	A
3/8 " 24 tpi	5325-01-525-3856	A

3. Turn hex nut onto cap screw (use a grade 8), follow by threading Gardsert™ (1) (Fig. 4-60) (Gardsert™ is listed as "Tool Kit, Screw Insert" in Appendix A) onto cap screw keeping cutting threads open. Make sure to align Gardsert™ flush with workpiece as shown in Fig. 4-60.

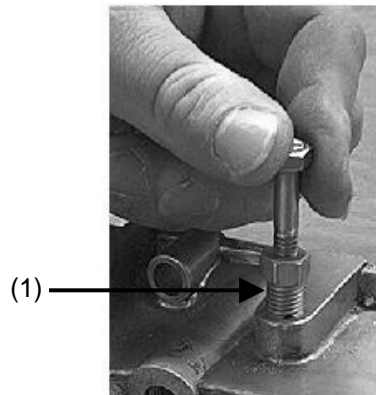

Figure 4-60. Gardsert™ flush with workpiece.

4. Carefully align Gardsert™ to hole and turn into hole clockwise using a wrench on hex nut. Using index finger, hold bolt in place.

TM 9-4910-783-13&P

REPAIR (cont)

5. Hold cap screw (1) (Fig. 4-63) and loosen hex nut, turning counter clockwise.



Figure 4-61. Loosening of hex nut.

6. Remove cap screw.

END OF TASK

TM 9-4910-783-13&P

THIS TASK COVERS:

- a. Removal
- b. Installation

INITIAL SETUP:

Tools and Special Tools:
Base Tools
GMTK

References:

Materials/Parts:
GAA Lubricant (Item 17, WP 0057 00)

Equipment Conditions:
All switches and circuit breakers placed in OFF position, power off

Personnel Required: 8

WARNING



Heavy object requires eight-person lift.

a. REMOVAL

1. Using a 5/16" hex key (WP 0058 00, SATS Base Tool Component List), remove the eight bolts (1) attaching jack that is to be removed (Fig. 4-62).

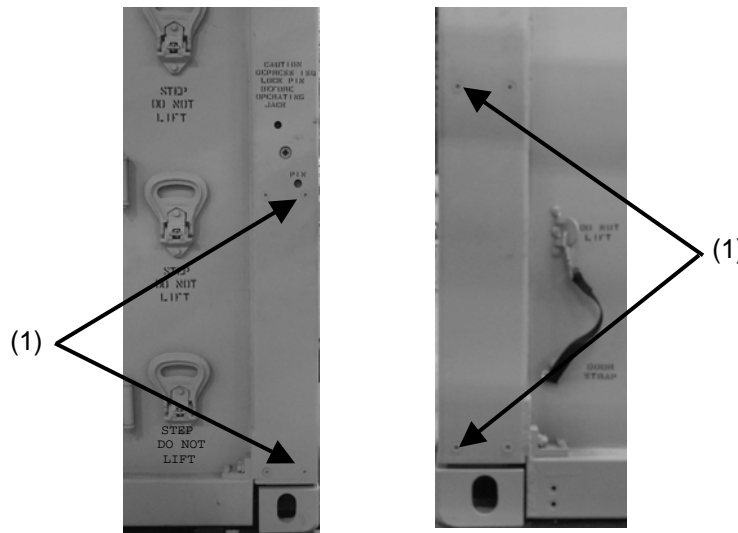

Figure 4-62. Corner posts of container.

TM 9-4910-783-13&P

a. REMOVAL (cont)

- Using a 3/8" hex key (WP 0058 00, SATS Base Tool Component List), remove two bolts located on vertical from two corner gusset plates (1) (see Fig. 4-65) located on either side of jack.

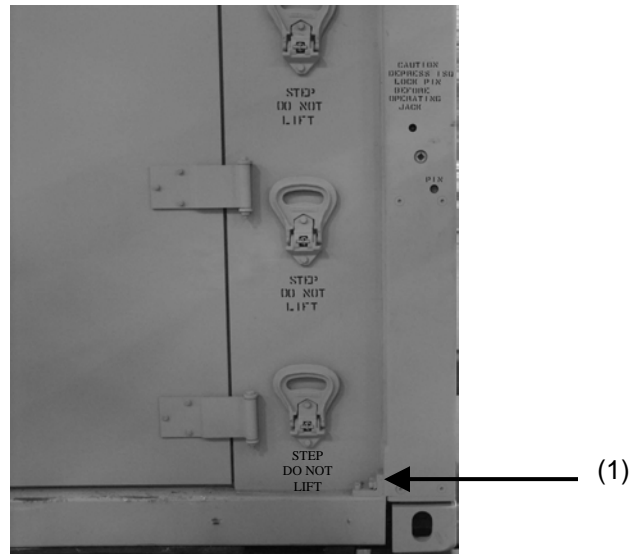

Figure 4-63. Corner gusset on ISO corner posts

- Position bottom of container approximately 40" off ground using crane, hoist (WP 0007 00, Moving Container with a Crane or Hoist), or forklift (WP 0007 00, Moving Container with a Forklift).

CAUTION

Once the container has been lifted more than 36" off ground, the 250 lb. jack will fall from container.

- Using an eight-person lift, move jack out from under container.
- Lower container and place on ground.

b. INSTALLATION

NOTE

Upon installation of jacks, lubricate with GAA Lubricant (Item 17, WP 0057 00).

- Ensure you have the correct jack (LH, RH) by checking part number on identification plate (1) (Fig. 4-64). RH jack is PN 58300209. LH jack is PN 58300208.

TM 9-4910-783-13&P

b. INSTALLATION (cont)

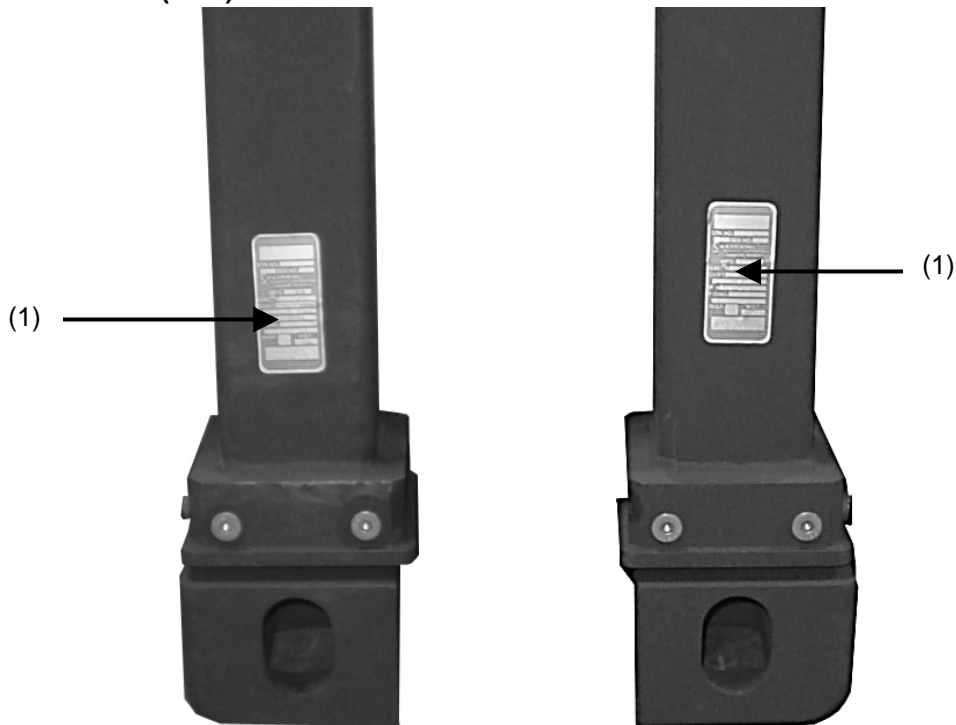

Figure 4-64. LH and RH lift jack assemblies.

2. Using a crane, hoist (WP 0007 00), or forklift (WP 0007 00), lift container 40" off the ground.
3. Using an eight-person lift, place lift jack directly beneath corner of container that it will be inserted.
4. Slowly lower container ensuring jack is being inserted into corner properly.
5. Insert eight bolts into provided holes (see Fig. 4-62) and tighten using a 5/16" hex key.
6. Place four bolts in two gusset plates (1) on either side of jack (Fig. 4-63).

WARNING

Gusset plates **MUST** be firmly tightened to prevent injury to personnel or damage to container.

7. Tighten bolts using a 3/8" hex key (torque to 60 ft-lb).

END OF TASK

TM 9-4910-783-13&P

CAULKING REPAIRED AREAS

0045 00

1. Mix sufficient amount of sealing compound (Item 16, WP 0057 00) in accordance with manufacturer's instructions.

NOTE

Maximum application life of sealing compound is two hours.

2. Just prior to application of sealing compound, clean surface to be sealed with cloth (Item 10, WP 0057 00) dampened with solvent (Item 6, WP 0057 00).

3. Dry with clean cloth before solvent evaporates in order to prevent contamination.

4. Apply sealing compound with caulking gun (or spatula) in 1/8-inch (3.18 mm) minimum fillets.

5. Nominal curing time is 72 hours at 75°F.

END OF TASK

TM 9-4910-783-13&P

PAINT REFINISHING

0046 00

Sand Paint Data Plate (with scuff strip)

THIS CONTAINER PAINTED WITH CARC PAINT			
	PAINT TYPE	MIL SPEC COLOR	COLOR CODE FED-STD-595
INTERIOR PAINT	EPOXY	MIL-C-22750 TYPE I	27875
EXTERIOR PAINT	ALIPHATIC POLYURETHANE	MIL-C-53039	33446
PRIMER	EPOXY	MIL-P-53022	
FLOOR PAINT	WALKWAY COMPOUND	MIL-W-5044 TYPE I GRAY	26251
FLOOR PAINT	WALKWAY COMPOUND	MIL-W-5044 TYPE II GRAY	26251

1. Prepare surface for painting by removing all corrosion by wire brushing, sanding, or application of corrosion-removing compounds.
2. Chemically treat all aluminum parts in accordance with MIL-C-5541, Class 1A.
3. Areas to be painted shall be free of dust, residue, and cleaning compounds before refinishing.
4. Solvent, primer, or paint shall not be applied to seals or non-metal parts. Mask such parts with masking tape for protection.

NOTE

Check paint data plate for primer used.

5. Mix and apply epoxy primer coating in accordance with MIL-P-53022 or MIL-P-23377.
6. Allow to dry thoroughly before applying finish coat.
7. Mix and apply paint in accordance with manufacturer's instructions.
8. Apply two separate, uniform coats. Make sure there are no sags or runs.
9. Allow first coat to dry before applying second coat.

END OF TASK

TM 9-4910-783-13&P

PREPARATION FOR MOVEMENT/SHIPMENT

If container has been used on ground, it must be loaded onto trailer for transport by any means other than air (See LOADING CONTAINER ONTO TRAILER).

WARNING

Never transport container with door open. Transporting container with door open may cause serious injury or death to personnel.

1. The container is equipped with ratchet buckles for security and restraint during transport. To use ratchet buckles, follow these steps:
 - a. Fully engage hooks to tie-down ring.
 - b. Pull slack through buckle.
 - c. Tighten strap by ratcheting handle until secure. A minimum of two turns of webbing should be around reel after tensioning. Handle should be rotated back against buckle frame to engage latch lock. **DO NOT OVERTIGHTEN STRAP.**
 - d. To release, pull back on handle latch and rotate handle approximately 120° then pull straps away from ratchet buckle.
2. Ensure all loose tools have been secured by procedure listed above and instructions listed in WP 0005 00.
3. Ensure all racks/drawers are shut and secured.
4. The personnel door should be locked.
5. The maximum weight of container should not exceed allowable limit (WP 0003 00, Equipment Data).
6. Secure all stowed items. Any items too large should be secured to the floor using integral cargo tie-down rings.
7. Ensure ramp is removed from container and stored properly. Door of ramp storage compartment on trailer should be shut and secured.
8. Leveling jacks should be in stowed position.
9. Folding steps on right side of container (troop door end wall) may be lowered to allow personnel to climb on top of container. This allows easier access to ISO corners for attachment purposes. They must be placed in upright position prior to shipment to maintain container envelope.
10. Ensure Generator and ECU are secured and access/vent panels are closed.
11. Generator panels, vent panels, and ECU panel should be in closed position.
12. For ground transport, decompression panel should be closed.

TM 9-4910-783-13&P

PREPARATION FOR MOVEMENT/SHIPMENT (cont)

13. For air transport, decompression panel should be open.
14. Use a spotter to ensure forklift tines enter forklift tubes in container base.
15. Remove all power and grounding cable connections and stow cables before moving unit (WP 0005 00, Power Shutdown).

LOADING CONTAINER ONTO TRAILER

1. Remove locking pin (3) from ISO block T-lock (Fig. 4-65) located on the ISO extension block, which is attached to trailer.

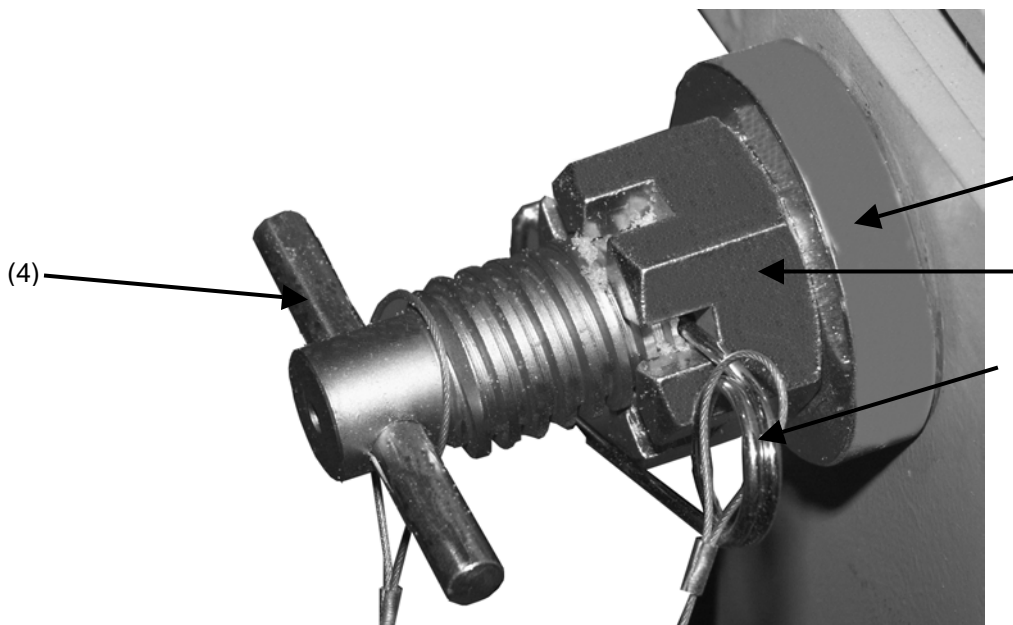

Figure 4-65. Block T-lock with pin.

2. With an 18" automotive adjustable wrench (WP 0058 00, SATS Base Tool Component List) turn nut (2) of block T-lock counterclockwise to loosen.
3. While holding collar (1), rotate T-handle (4) to vertical position.
4. Pull to remove block T-lock from ISO extension block.
5. Lift container with forklift (0007 00, Moving Container with a Forklift), hoist or crane (0007 00, Moving Container with a Crane or Hoist) about 18" off ground.

TM 9-4910-783-13&P

LOADING CONTAINER ONTO TRAILER (cont)

6. Attach an ISO extension block (1) to each of four corners of container by following steps seven through ten below (Fig. 4-66).

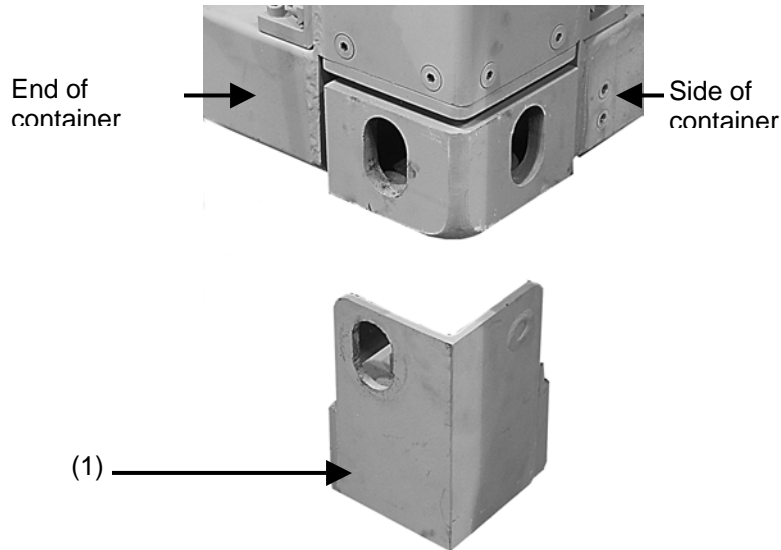

Figure 4-66. ISO extension block aligned with corner of container.

7. Insert block T-lock (1) in ISO block corner slot (4) (Fig. 4-67).

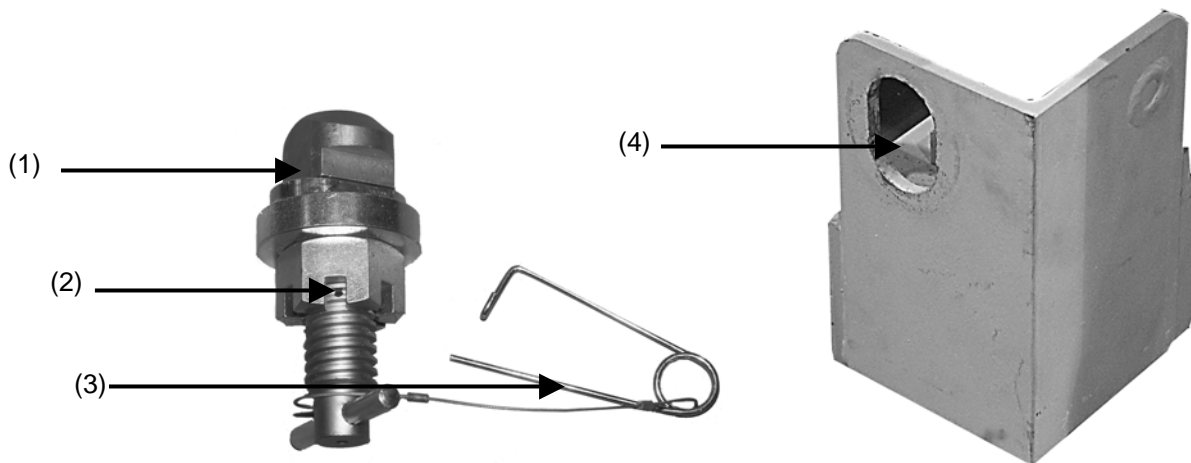

Figure 4-67. Block T-lock and ISO Block.

8. While holding collar, rotate T-handle to horizontal position.

9. With an 18" automotive adjustable wrench (WP 0058 00, SATS Base Tool Component List), rotate nut clockwise to tighten until secure, revealing holes (2) for locking pin (Fig. 4-67).

TM 9-4910-783-13&P

LOADING CONTAINER ONTO TRAILER (cont)

10. Insert locking pin into holes (2) between nut notches and clasp pin shut (Fig.4-67).
11. Place container on trailer and secure by rotating handle (1) of trailer lock (located at each corner) 90° (Fig. 4-68).

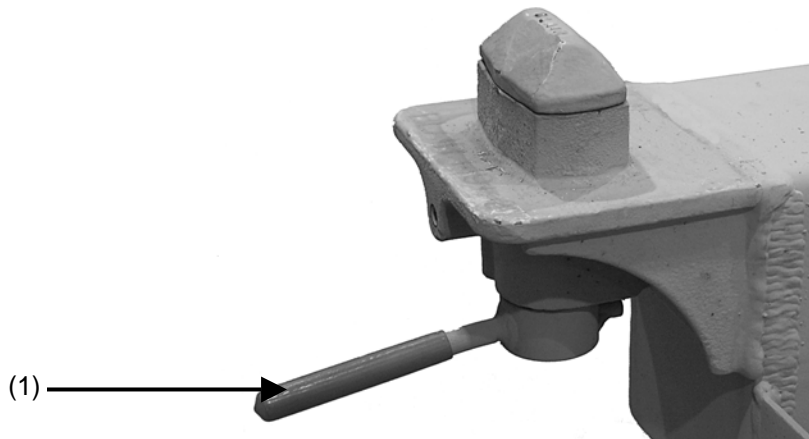

Figure 4-68. Trailer lock.

REMOVING CONTAINER FROM TRAILER

1. Unlock container from trailer by rotating four lock handles 90° (Fig. 4-68).
2. Remove locking pin (3) from block T-lock (Fig. 4-69).

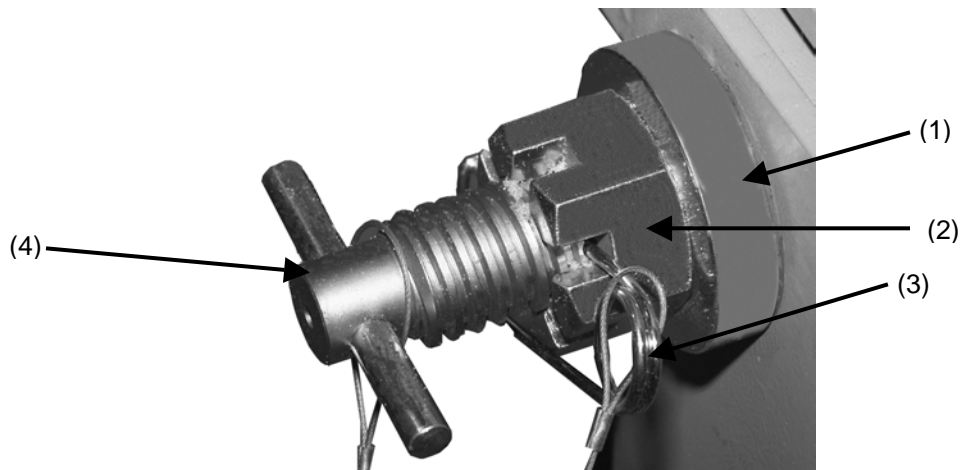

Figure 4-69. Block T-lock with locking pin inserted.

3. With an 18" automotive adjustable wrench (WP 0058 00, SATS Base Tool Component List) turn nut (2) of block T-lock counterclockwise to loosen.

TM 9-4910-783-13&P

REMOVING CONTAINER FROM TRAILER (cont)

4. Lift container with forklift (WP 0007 00, Moving Container with a Forklift), hoist or crane (WP 0007 00, Moving Container with a Crane or Hoist) from trailer and position approximately 18" off ground.

CAUTION

Removal of the ISO extension blocks requires two personnel.

5. While container is on lift, remove four ISO extension blocks by holding collar (1), rotating the T-handle (4) to vertical position and pulling block T-lock straight out.

NOTE

ISO extension blocks must be kept with trailer.

6. Continue lowering container to the ground.

LOADING CONTAINER ONTO FLAT RACK

1. Lift container with forklift (WP 0007 00, Moving Container with a Forklift), hoist or crane (WP 0007 00, Moving Container with a Crane or Hoist) from ground.

2. Place container on flat rack so ISO connections align with ISO corners on container.

3. Secure container to flat rack by rotating latches (1) up into ISO corner (2) and securing with pin (3) (Fig. 4-70).

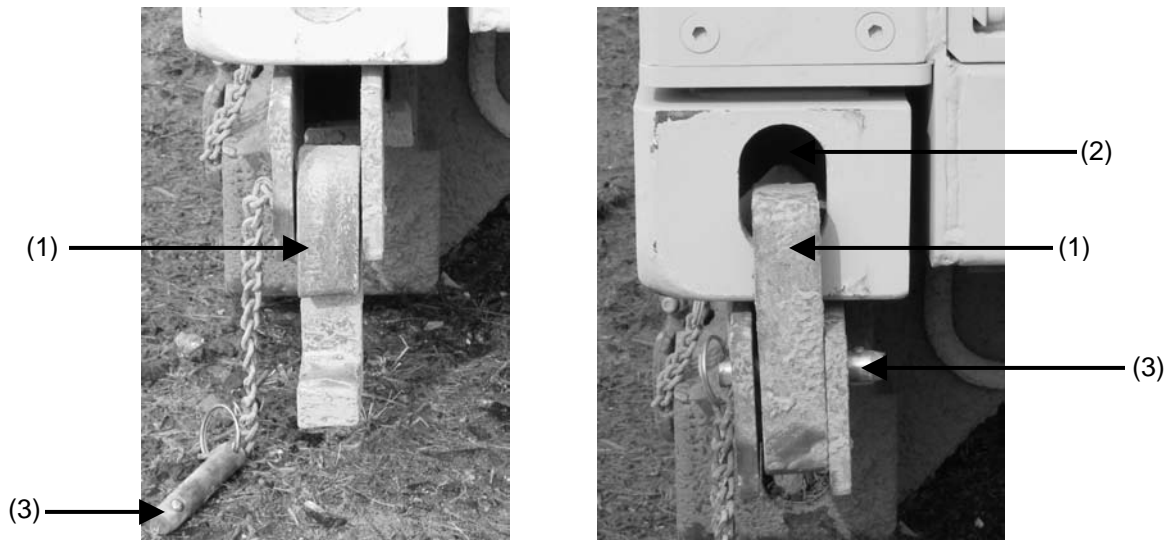

Figure 4-72. Flat rack latch.

4. Rotate locks (1) (Fig. 4-70) of flat rack (located at front of flat rack) 90°.

TM 9-4910-783-13&P

LOADING CONTAINER ONTO FLAT RACK (cont)

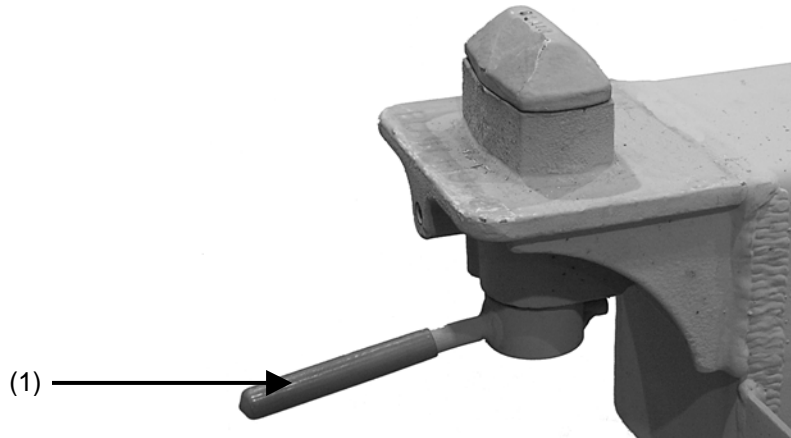

Figure 4-71. Flat rack lock.

REMOVING CONTAINER FROM FLAT RACK

1. Unlock flat rack from container at two front ISO corners by rotating lock handles (1) 90° (Fig. 4-71).
2. Unlatch container from flat rack at each of four ISO corners.
3. Lift container with forklift (WP 0007 00, Moving Container with a Forklift), hoist or crane (WP 0007 00, Moving Container with a Crane or Hoist) from flat rack and place on ground.

PREPARATION FOR STORAGE

There are no specific procedures necessary for storage of container. However, it is important when storing the SATS unit that personnel are aware of the following:

1. SATS should be stored in a secure location and, if necessary, monitored.
2. For long term storage, raise container off ground/floor and support it on three 4" x 4" (102 x 102 mm) wood beams that span full width of container. Position one beam at each end of container and one at mid length.

END OF WORK PACKAGE

TM 9-4910-783-13&P

WIRE LIST

0048 00

Wire No.	Size Awg And Color	From	To
W101	12 BLK	A2-CB1	A3-A (L1)
W102	12 RED	A2-CB1	A3-B (L2)
W103	12 BLU	A2-CB1	A3-C (L3)
W1GND1	12 GRN	A2-GND BUS	A3-E
W104	12 BLK	A2-CB2	S3
W105	12 WHT	A2-NEUT	DS (1,2,3) NEUT DS (10 & 11) NEUT
W1GND2	12GRN	A2-GND BUS	DS (1,2,3) GND
W106	12 RED	A2-CB4	J (11,12,13,14) PWR
W107	12 WHT	A2-GND BUS	J (11,12,13,14) NEUT
W1GND4	12 GRN	A2-GND BUS	J (11,12,13,14) GND
W108	12 BLU	A2-CB6	J (15,16,17,18) PWR
W109	12 GRN	A2-NEUT	J (15,16,17,18) NEUT
W1GND6	12 WHT	A2-GND BUS	J (15,16,17,18) GND
W110	10 BLK	A2-CB7	J101-A
W111	10 RED	A2-CB7	J101-B
W112	10 BLU	A2-CB7	J101-C
W1GND7	10 GRN	A2-GND BUS	J101-D
W113	10 BLK	A2-CB8	J (102 & 103) PWR
W114	10 GRN	A2-NEUT	J (102 & 103) NEUT
W1GND8	10 WHT	A2-GND BUS	J (102 & 103) GND
W115	12 RED	A2-CB10	M1-L
W116	12 WHT	A2-NEUT	M1-N
W1A1	2 BLK	A1-A	CB19-A (L1)
W1B1	2 RED	A1-B	CB19-B (L2)
W1C1	2 BLU	A1-C	CB19-C (L3)
W1N1	2 WHT	A1-N	A2-NEUT
WGND	6 GRN	A1-GND	A2-GND BUS
W201	12 BLK	S3	S2
W202	12 BLK	S2-BO	S1- (1 & 3)
W203	12 BLK	S1-NC	DS (10 & 11) PWR
W204	12 BLK	S1-NO	DS (1,2,3) PWR

END OF WORK PACKAGE

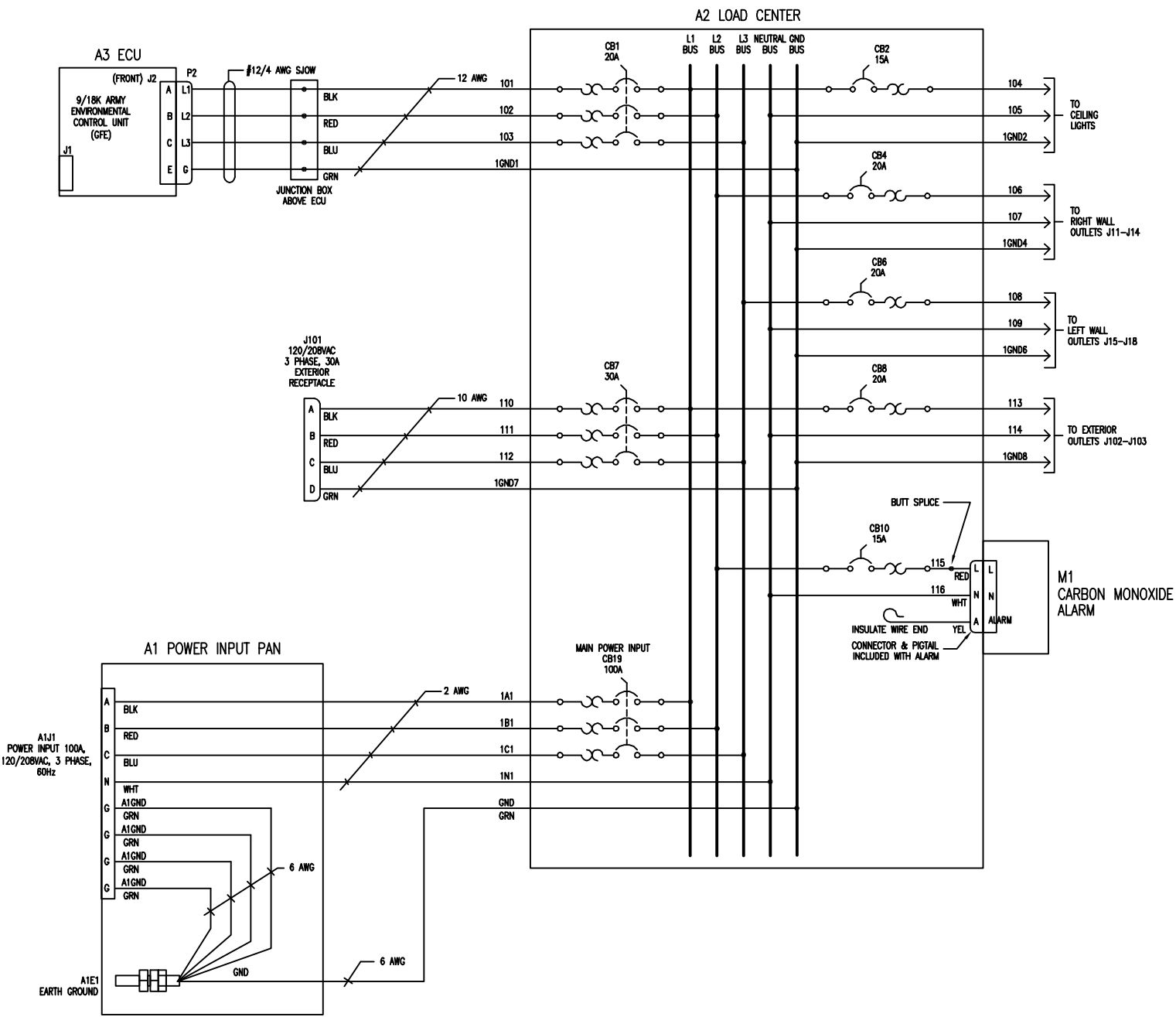

Space	Label	Space	Label
1	ECU POWER PHASE #1	2	CEILING LIGHTS
3	ECU POWER PHASE #2	4	RIGHT SIDE WALL OUTLETS
5	ECU POWER PHASE #3	6	LEFT SIDE WALL OUTLETS
7	AIR COMPRESSOR PHASE #1	8	EXTERIOR WORK LIGHTS OUTLETS
9	AIR COMPRESSOR PHASE #2	10	CARBON MONOXIDE DETECTOR
11	AIR COMPRESSOR PHASE #3	12	NOT USED
13	NOT USED	14	NOT USED
15	NOT USED	16	NOT USED
17	NOT USED	18	NOT USED
19	MAIN POWER PHASE #1	20	NOT USED
21	MAIN POWER PHASE #2	22	NOT USED
23	MAIN POWER PHASE #3	24	NOT USED

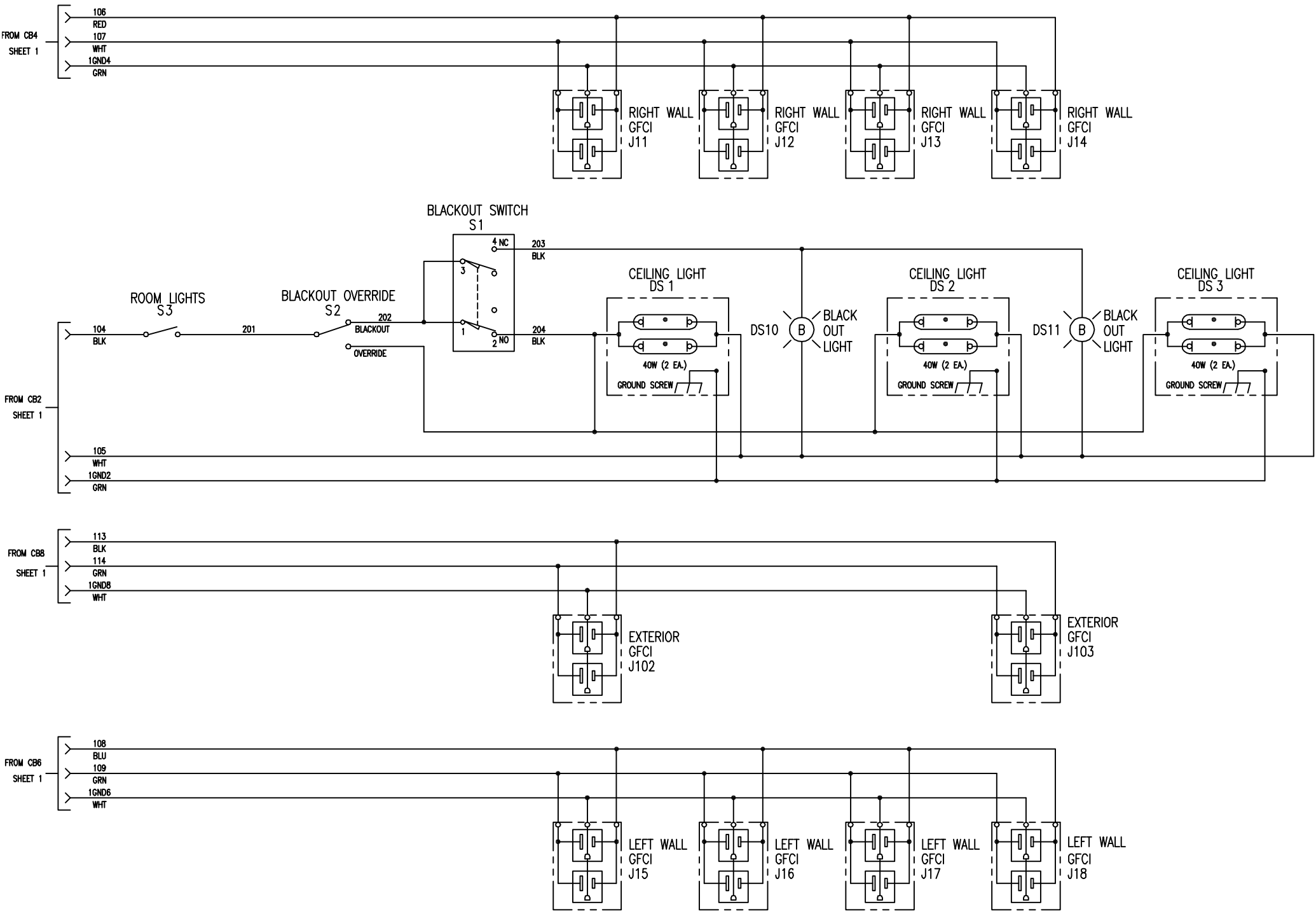

COMMUNICATIONS PAN

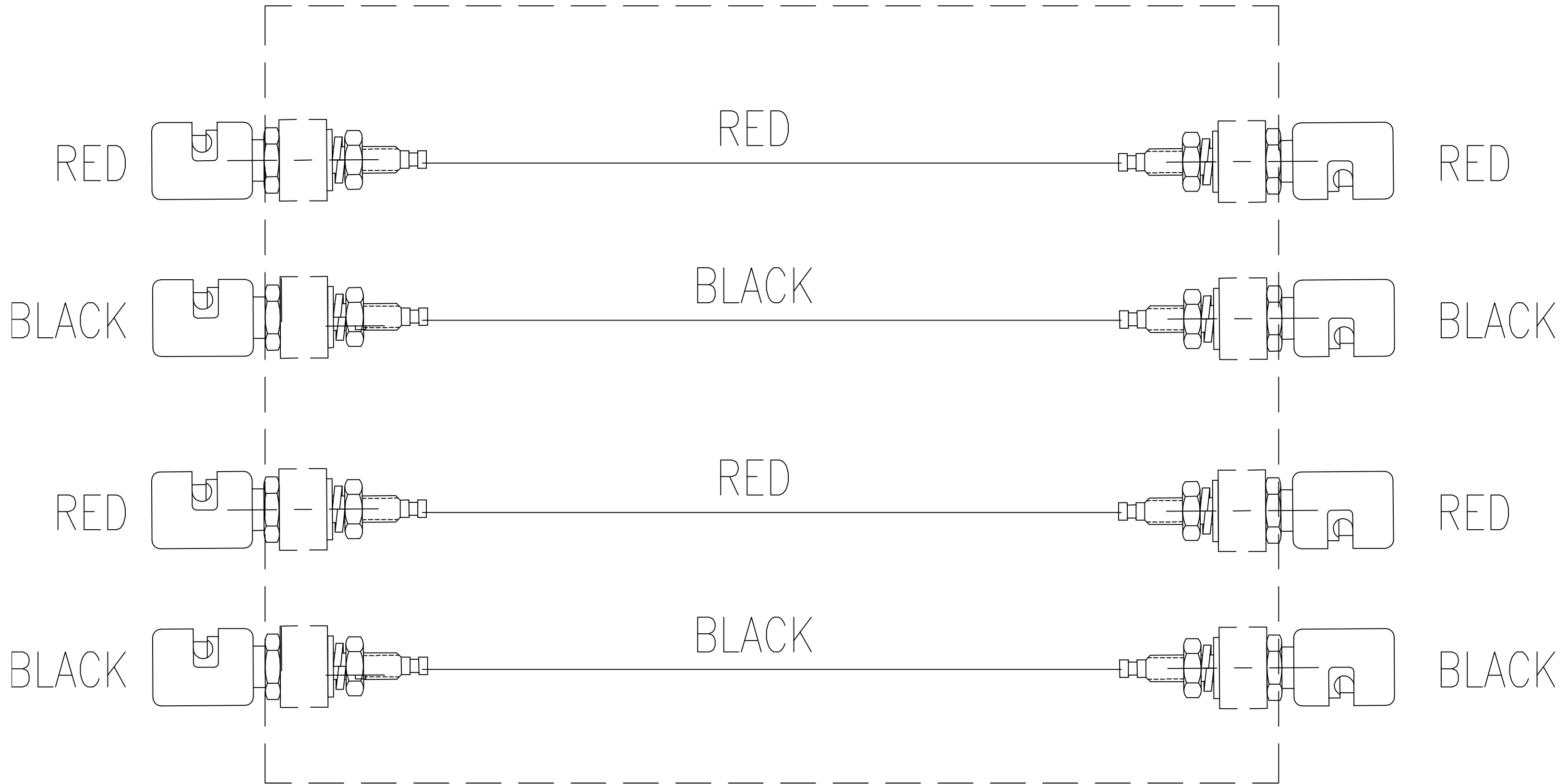

FIELD PHONE BINDING POST CONNECTIONS

TM 9-4910-783-13&P

CHAPTER 5
SUPPORTING INFORMATION
FOR
STANDARD AUTOMOTIVE TOOL SET (SATS)

TM 9-4910-783-13&P

REFERENCES

0049 00

REFERENCES

SCOPE

This section lists all forms and publications referenced in this manual.

FORMS

Component Removal and Repair/Overhaul Record	DA Form 2410
Product Quality Deficiency Report	SF 368
Recommended Changes to Publications and Blank Forms	DA Form 2028

ARMY REGULATIONS

Reporting of Transportation Discrepancies in	AR 55-38
Reporting of Item and Packaging Discrepancies	AR 735-11-2

PAMPHLETS

Consolidated Index of Army Publications and Blank Forms	DA Pam 25-30
The Army Maintenance Management System (TAMMS) Users Manual	DA Pam 750-8

MILITARY STANDARDS

MIL-STD-209J	Interface Standard for Lifting and Tiedown Provisions
MIL-STD-913A	Requirements for the Certification of Sling Loaded Military Equipment for External Transportation by Department of Defense Helicopters

TECHNICAL MANUALS

TM 5-4120-386-14	Air Conditioner Horizontal, Compact, 9000 BTU/Hr, 208 Volt Three Phase 50/60 Hertz
TM 9-6115-642-10	Generator Set Skid Mounted, Tactical Quiet 10KW, 60 and 400 Hertz
TM 9-2330-328-14&P	Chassis, Containerized Kitchen Trailer: 7 ½ -Ton, 4-Wheel XCK2000

COMMERCIAL LITERATURE

Operating Instructions, Battery and Charging System Analyzer

Operating Instructions, Booster Cable Assembly

Operating Instructions, Reciprocating Compressor Unit

Operating Instructions, Mechanics Creeper

Operating Instructions, Tube Cutting and Flaring Kit

Operating Instructions, 24" Lightweight Bolt Cutter

COMMERCIAL LITERATURE (cont)

Operating Instructions, Portable Degreaser

Operating Instructions, Rechargeable Battery Operated Drill-Driver

Operating Instructions, 1/2" Electric Drill-Driver

Operating Instructions, 3/8" Right Angle Rechargeable Battery Operated Drill

Operating Instructions, 3/8" Portable Electric Drill

Operating Instructions, Fire Extinguisher

Operating Instructions, Brake System Filler and Bleeder Kit

Operating Instructions, Drum Dolly for the Grease Gun Kit

Operating Instructions, Grease Gun for the Grease Gun Kit

Operating Instructions, Mini Lube for the Grease Gun Kit

Operating Instructions, Grease Filler Pump for the Grease Gun Kit

Operating Instructions, Pneumatic Grease Gun

Operating Instructions, Utility Grinding Machine

Operating Instructions, Pneumatic Hammer

Operating Instructions, Rechargeable Battery Operated Light

Operating Instructions, Multimeter

Operating Instructions, Torque Multiplier

Operating Instructions, Wire Twister Pliers

Operating Instructions, Lifting Pneumatic Bag Kit

Operating Instructions, Mechanical Puller Set

Operating Instructions, 4 1/2" Sander/Grinder

Operating Instructions, Portable Drill Sharpener

Operating Instructions, Soldering Gun

Operating Instructions, Radiator Pressure Test Kit

TM 9-4910-783-13&P

REFERENCES

0049 00

COMMERCIAL LITERATURE (cont)

Operating Instructions, Antifreeze Solution Tester

Operating Instructions, Blind Fastener Installation Tool Kit

Operating Instructions, Pneumatic Abrasive Cutting Tool Kit

Operating Instructions, Tire Bead Breaker – Tire Service Tool Kit

Operating Instructions, Air Hydraulic Pump –Tire Service Tool Kit

Operating Instructions, Brazing and Soldering Set

Operating Instructions, 3/8" and 1/2" Drive Impact Wrench Master Wrench Set

Operating Instructions, 1/4" and 3/8" Drive Pneumatic Ratchet Wrench Kit

Operating Instructions, 75 FT.LBS 3/8" Drive Ratcheting Click Torque Wrench

Operating Instructions, 345NM 1/2" Drive Click Torque Wrench

Operating Instruction, Torque Wrench Bar

Operating Instructions, Hand Hydraulic Jack Kit

Operating Instructions, 30 Ton Hand Hydraulic Bottle Jack

Operating Instructions, 3 Ton Engine and Transmission Sling

Operating Instructions, 2 Ton Engine and Transmission Sling

Operating Instructions, Large Hose End Crimping Tool Kit

TM 9-4910-783-13&P

THE ARMY MAINTENANCE SYSTEM MAC

This introduction provides a general explanation of all maintenance and repair functions authorized at the two maintenance levels under the Two-Level Maintenance System concept.

The MAC (immediately following the introduction) designates overall authority and responsibility for the performance of maintenance functions on the identified end item or component. The application of the maintenance functions to the end item or component shall be consistent with the capacities and capabilities of the designated maintenance levels, which are shown on the MAC in column (4) as:

Field – includes two columns, Unit maintenance and Direct Support maintenance. The Unit maintenance column is divided again into two more subcolumns, C for Operator or Crew and O for Unit maintenance.

Sustainment – includes two subcolumns, General Support (H) and Depot (D)

The tools and test equipment requirements (immediately following the MAC) list the tools and test equipment (both special tools and common tool sets) required for each maintenance function as referenced from the MAC.

The remarks (immediately following the tools and test equipment requirements) contain supplemental instructions and explanatory notes for a particular maintenance function.

MAINTENANCE FUNCTIONS

Maintenance functions are limited to and defined as follows:

1. **Inspect.** To determine the serviceability of an item by comparing its physical, mechanical, and/or electrical characteristics with established standards through examination (e.g., by sight, sound, or feel). This includes scheduled inspection and gagings and evaluation of cannon tubes.
2. **Test.** To verify serviceability by measuring the mechanical, pneumatic, hydraulic, or electrical characteristics of an item and comparing those characteristics with prescribed standards on a scheduled basis, i.e., load testing of lift devices and hydrostatic testing of pressure hoses.
3. **Service.** Operations required periodically to keep an item in proper operating condition; e.g., to clean (includes decontaminate, when required), to preserve, to drain, to paint, or to replenish fuel, lubricants, chemical fluids, or gases. This includes scheduled exercising and purging of recoil mechanisms. The following are examples of service functions:
 - a. **Unpack.** To remove from packing box for service or when required for the performance of maintenance operations.
 - b. **Repack.** To return item to packing box after service and other maintenance operations.
 - c. **Clean.** To rid the item of contamination.
 - d. **Touch up.** To spot paint scratched or blistered surfaces.
 - e. **Mark.** To restore obliterated identification.
4. **Adjust.** To maintain or regulate, within prescribed limits, by bringing into proper position, or by setting the operating characteristics to specified parameters.
5. **Align.** To adjust specified variable elements of an item to bring about optimum or desired performance.

TM 9-4910-783-13&P

6. Calibrate. To determine and cause corrections to be made or to be adjusted on instruments of test, measuring, and diagnostic equipment used in precision measurement. Consists of comparisons of two instruments, one of which is a certified standard of known accuracy, to detect and adjust any discrepancy in the accuracy of the instrument being compared.
7. Remove/Install. To remove and install the same item when required to perform service or other maintenance functions. Install may be the act of emplacing, seating, or fixing into position a spare, repair part, or module (component or assembly) in a manner to allow the proper functioning of an equipment or system.
8. Paint. To prepare and spray color coats of paint so that the ammunition can be identified and protected. The color indicating primary use is applied, preferably, to the entire exterior surface as the background color of the item. Other markings are to be repainted as original so as to retain proper ammunition identification.
9. Replace. To remove an unserviceable item and install a serviceable counterpart in its place "Replace" is authorized by the MAC and assigned maintenance level is shown as the third position code of the Source, Maintenance and Recoverability (SMR) code.
10. Repair. The application of maintenance services, including fault location/troubleshooting, removal/installation, disassembly/assembly procedures and maintenance actions to identify troubles and restore serviceability to an item by correcting specific damage, fault, malfunction, or failure in a part, subassembly, module (component or assembly), end item, or system.

NOTE

The following definitions are applicable to the "repair" maintenance function: Services. Inspect, test, service, adjust, align, calibrate, and/or replace.

Fault location/troubleshooting. The process of investigating and detecting the cause of equipment malfunctioning; the act of isolating a fault within a system or Unit Under Test (UUT).

Disassembly/assembly. The step-by-step breakdown (taking apart) of a spare/functional group coded item to the level of its least component, that is assigned an SMR code for the level of maintenance under consideration (i.e., identified as maintenance significant).

Actions. Welding, grinding, riveting, straightening, facing, machining, and/or resurfacing.

11. Overhaul. That maintenance effort (service/action) prescribed to restore an item to a completely serviceable/operational condition as required by maintenance standards in appropriate technical publications. Overhaul is normally the highest degree of maintenance performed by the Army. Overhaul does not normally return an item to like new condition.
12. Rebuild. Consists of those services/actions necessary for the restoration of unserviceable equipment to a like new condition in accordance with original manufacturing standards. Rebuild is the highest degree of material maintenance applied to Army equipment. The rebuild operation includes the act of returning to zero those age measurements (e.g., hours/miles) considered in classifying Army equipment/components.

TM 9-4910-783-13&P

EXPLANATION OF COLUMNS IN THE MAC

Column (1) Group Number. Column (1) lists Functional Group Code (FGC) numbers, the purpose of which is to identify maintenance significant components, assemblies, subassemblies, and modules with the Next Higher Assembly (NHA).

Column (2) Component/Assembly. Column (2) contains the item names of components, assemblies, subassemblies, and modules for which maintenance is authorized.

Column (3) Maintenance Function. Column (3) lists the functions to be performed on the item listed in column (2). (For a detailed explanation of these functions refer to "Maintenance Functions" outlined above).

Column (4) Maintenance Level. Column (4) specifies each level of maintenance authorized to perform each function listed in column (3), by indicating work time required (expressed as man-hours in whole hours or decimals) in the appropriate subcolumn. This work time figure represents the active time required to perform that maintenance function at the indicated level of maintenance. If the number or complexity of the tasks within the listed maintenance function varies at different maintenance levels, appropriate work time figures are to be shown for each level. The work time figure represents the average time required to restore an item (assembly, subassembly, component, module, end item, or system) to a serviceable condition under typical field operating conditions. This time includes preparation time (including any necessary disassembly/assembly time), troubleshooting/fault location time, and quality assurance time in addition to the time required to perform the specific tasks identified for the maintenance functions authorized in the MAC. The symbol designations for the various maintenance levels are as follows:

Field:

- C Operator or Crew maintenance
- O Unit maintenance
- F Direct Support maintenance

Sustainment:

- L Specialized Repair Activity
- H General Support maintenance
- D Depot maintenance

NOTE

The "L" maintenance level is not included in column (4) of the MAC. Functions to this level of maintenance are identified by work time figure in the "H" column of column (4), and an associated reference code is used in the REMARKS column (6). This code is keyed to the remarks and the SRA complete repair application is explained there.

Column (5) Tools and Equipment Reference Code. Column (5) specifies, by code, those common tool sets (not individual tools), common Test, Measurement and Diagnostic Equipment (TMDE), and special tools, special TMDE and special support equipment required to perform the designated function. Codes are keyed to the entries in the tools and test equipment table.

Column (6) Remarks Code. When applicable, this column contains a letter code, in alphabetical order, which is keyed to the remarks table entries.

TM 9-4910-783-13&P

EXPLANATION OF COLUMNS IN THE TOOLS AND TEST EQUIPMENT REQUIREMENTS

Column (1) – Tool or Test Equipment Reference Code. The tool or test equipment reference code correlates with a code used in column (5) of the MAC.

Column (2) – Maintenance Level. The lowest level of maintenance authorized to use the tool or test equipment.

Column (3) – Nomenclature. Name or identification of the tool or test equipment.

Column (4) – National Stock Number (NSN). The NSN of the tool or test equipment.

Column (5) – Tool Number. The manufacturer's part number.

EXPLANATION OF COLUMNS IN THE REMARKS

Column (1) – Remarks Code. The code recorded in column (6) of the MAC.

Column (2) – Remarks. This column lists information pertinent to the maintenance function being performed as indicated in the MAC.”

TM 9-4910-783-13&P

MAINTENANCE ALLOCATION CHART STANDARD AUTOMOTIVE TOOL SET

0051 00

MAINTENANCE ALLOCATION CHART for Standard Automotive Tool Set (SATS)

(1) GROUP NUMBER	(2) COMPONENT/ ASSEMBLY	(3) MAINTENANCE FUNCTION	(4) MAINTENANCE LEVEL					(5) TOOLS AND TEST EQUIPMENT	(6) REMARKS CODE	
			FIELD		SUSTAINMENT					
			UNIT		DS	GS	DEPOT			
			C	O	F	H	D			
00	SATS	Inspect Test Replace Repair	4.0 2.0 4.3	 9.0 37.0				1 2,3 2,3		
01	CONTAINER	Inspect Test Replace Repair	3.3 1.3 4.0	 8.3 36.0				1 2,3 2,3,4,5,6		
0101	ECU End Wall	Inspect Test Replace Repair	0.1	 0.5 5.0 25.				1 2,3 2,3,4,5,6		
01010101	Prop Rod Assembly	Inspect Replace	0.1	 0.5				2		
010105	Exterior Outlet Assembly	Inspect Test Replace	0.3	 0.2 0.5				1 2,3		
0201	Outside Personnel End Wall	Inspect Test Replace Replace Repair	0.2 0.4	 0.3 0.45 26.0				1 2,3 2,3,4,5,6 2,3,4,5,6		
020101	Step	Inspect Replace	0.3	 0.5				2		
020103	Kipper Data Plate	Inspect Replace	0.2 0.2					2		
020107	Exterior Outlet	Inspect Test Replace	0.3	 0.2 0.5				1 2,3		

TM 9-4910-783-13&P

MAINTENANCE ALLOCATION CHART STANDARD AUTOMOTIVE TOOL SET

0051 00

MAINTENANCE ALLOCATION CHART (CON'T) for Standard Automotive Tool Set (SATS)

(1) GROUP NUMBER	(2) COMPONENT/ ASSEMBLY	(3) MAINTENANCE FUNCTION	(4) MAINTENANCE LEVEL					(5) TOOLS AND TEST EQUIPMENT	(6) REMARKS CODE	
			FIELD		SUSTAINMENT					
			UNIT		DS	GS	DEPOT			
			C	O	F	H	D			
020108	Personnel Door Assembly	Inspect Replace Repair	0.1	0.5 24.0				2,3 2,3		
0301	Left-Hand Side Wall Outside	Inspect Replace Repair	0.5	0.15 26.0				2,3,4,5,6 2,3,4,5,6		
030102	Generator Exhaust Panel	Inspect Replace	0.1	0.3				2		
030108	Generator Access Door	Inspect Replace	0.1	0.3				2		
0401	Right-Hand Side Wall Outside	Inspect Test Replace Repair	0.3 0.3	1.30 0.45 26.0				1 2,3,4,5,6 2,3,4,5,6		
040101	Generator Access Door	Inspect Replace	0.1 0.3					2		
040110	Communications Panel Assembly	Inspect Test Replace	0.1	1.0 1.0				1 2,3		
04010102	Door	Inspect Replace	0.3 0.3					2,3		
04010103	Housing Outside	Inspect Replace	0.3	2.5				2,3		
0501	Mechanical Room	Inspect Replace	0.15	10.0				2,3		

TM 9-4910-783-13&P

MAINTENANCE ALLOCATION CHART STANDARD AUTOMOTIVE TOOL SET

0051 00

MAINTENANCE ALLOCATION CHART (CON'T) for Standard Automotive Tool Set (SATS)

(1) GROUP NUMBER	(2) COMPONENT/ ASSEMBLY	(3) MAINTENANCE FUNCTION	(4) MAINTENANCE LEVEL					(5) TOOLS AND TEST EQUIPMENT	(6) REMARKS CODE	
			FIELD		SUSTAINMENT					
			UNIT		DS	GS	DEPOT			
			C	O	F	H	D			
050101	Safety Strap	Inspect Replace	0.3	0.3 0.1				2		
050104	Generator Slide Assembly	Inspect Replace	0.2	3.3				2,3		
05010103	Lower Rail Assembly	Inspect Replace		2.0 4.0				2,3		
0701	Right-Hand Wall Inside	Inspect Test Replace	0.3	1.30 3.0				1 2,3,4,5,6		
070101	Circuit Breaker Box Assembly	Inspect Test Replace	0.1	1.0 2.0				1 2		
0801	Mechanical Room Wall	Inspect Replace	0.1	0.3				2,3,4,5,6		
0901	Left-Hand Wall Inside	Inspect Replace	0.1	3.0				2,3		
0110	Door Entry Wall Inside	Inspect Test Replace	0.2 0.45 1.0					1 2,3		
0111	Floor	Inspect Replace	0.5 1.0					2,3		
0112	Ceiling	Inspect Test Replace	0.30	2.0 3.0				1 1,2,3		

TM 9-4910-783-13&P

MAINTENANCE ALLOCATION CHART STANDARD AUTOMOTIVE TOOL SET

0051 00

MAINTENANCE ALLOCATION CHART (CON'T) for Standard Automotive Tool Set (SATS)

(1) GROUP NUMBER	(2) COMPONENT/ ASSEMBLY	(3) MAINTENANCE FUNCTION	(4) MAINTENANCE LEVEL					(5) TOOLS AND TEST EQUIPMENT	(6) REMARKS CODE	
			FIELD		SUSTAINMENT					
			UNIT		DS	GS	DEPOT			
			C	O	F	H	D			
011201	Blackout Light	Inspect Test Replace	0.50	.30 .45				1 1,2,3		
011202	Light Assembly Fluorescent	Inspect Test Replace	0.5	0.3 1.30				1 2,3		

TM 9-4910-783-13&P

TOOL AND TEST EQUIPMENT REQUIREMENTS STANDARD AUTOMOTIVE TOOL SET 0052 00

(1) REFERENCE CODE	(2) MAINTENANCE CATEGORY	(3) NOMENCLATURE	(4) NATIONAL STOCK NUMBER (NSN)	(5) TOOL NUMBER
1	C,O	Multimeter	6625-01-489-5585	177
2	C, O	General Mechanic's Tool Kit	5180-01-481-8389	SC 5150-95-B47
3	C, O	Base Tool Set	4910-01-490-6453	SC 4910-95-A81
4	C, O	CARC Paint (MIL-C-46168) Green, 1 Gallon	8010-01-229-9561	M53039-001Q-34094
5	C, O	CARC Paint (MIL-C-46168) Tan, 1 Gallon	8010-01-276-3639	M5309-001G-33446
6	C, O	Aluminum Alloy Sheet Stock	9535-01-369-4114	AMS-QQ-A-250-11

TM 9-4910-783-13&P

REPAIR PARTS AND SPECIAL TOOLS LIST (RPSTL)

0053 00

SCOPE

This RPSTL lists and authorizes spares and repair parts, special tools, special test, measurement, and diagnostic equipment (TMDE), and other special support equipment required for performance of operator's, unit and direct support maintenance of Standard Automotive Tool Set. It authorizes the requisitioning, issue, and disposition of spares, repair parts and special tools as indicated by the source, maintenance, and recoverability (SMR) codes.

GENERAL

This repair parts and special tools list is divided into the following work packages:

- a. *Spare and Repair Parts List.* A list of spares and repair parts authorized by this RPSTL for use in the performance of maintenance. This list also includes parts that must be removed for replacement of the authorized parts. Parts lists are composed of functional groups in ascending alphanumeric sequence, with the parts in each group listed in ascending figure and item number sequence. Items listed are shown on the associated illustration.
- b. *Consumables*
- c. *Parts List Order Form.* Order form to be utilized when ordering parts.
- d. *Instructions for Requisitioning Parts from Commercial Sources.*

EXPLANATION OF COLUMNS IN THE REPAIR PARTS AND SPECIAL TOOLS LIST WORK PACKAGES

- a. **ITEM NO [Column (1)].** Indicates the number used to identify items called out in the illustration.
- b. **SMR CODE [Column (2)].** The SMR code containing supply/requisitioning information, maintenance level authorization criteria, and disposition instructions, as shown in the following breakout:

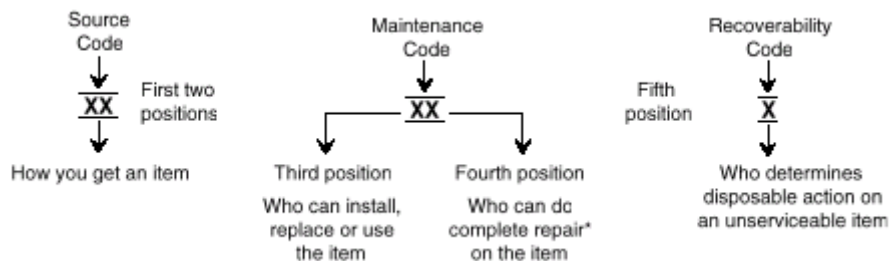

*Complete Repair: Maintenance capacity, capability, and authority to perform all corrective maintenance tasks of the "Repair" function in a use/user environment in order to restore serviceability to a failed item.

TM 9-4910-783-13&P

REPAIR PARTS AND SPECIAL TOOLS LIST (RPSTL)

0053 00

1. Source Code. The Source code tells you how to get an item needed for maintenance, repair or overhaul of an end item/equipment. Explanations of source codes follow:

Source Code	Application/Explanation
PA PB PC PD PE PF PG	Stocked items; use the applicable NSN to request/requisition items with these source codes. They are authorized to the category indicated by the code entered in the 3rd position of the SMR code. <p style="text-align: center;">NOTE Items coded PC are subject to deterioration.</p>
KD KF KB	Items with these codes are not to be requested/requisitioned individually. They are part of a kit that is authorized to the maintenance category indicated in the 3rd position of the SMR code. The complete kit must be requisitioned and applied.
MO –Made at unit/AVUM Level MF – Made at DS/AVIM level MH – Made at GS level ML – Made at SRA MD - Made at depot	Items with these codes are not to be requested/requisitioned individually. They must be made from bulk material which is identified by the part number in the DESCRIPTION AND USABLE ON CODE (UOC) column and listed in the bulk material group of the RPSTL. If the item is authorized to you by the 3rd position code of the SMR code, but the source code indicates it is made at a higher level, order the item from the higher level of maintenance.
AO - Assembled by unit/AVUM level AF - Assembled by DS/AVIM Level AH - Assembled by GS level AL - Assembled by SRA AD - Assembled by depot	Items with these codes are not to be requested/requisitioned individually. The parts that make up the assembled item must be requisitioned or fabricated and assembled at the level of maintenance indicated by the source code. If the 3 rd position code of the SMR code authorizes you to replace the item, but the source code indicates the item is assembled at a higher level, order the item from the higher level of maintenance.

TM 9-4910-783-13&P

Source Code	Application/Explanation
XA –	Do not requisition and “XA” coded item. Order the next higher assembly. (Refer to Note below.)
XB –	If an item is not available from salvage, order it using the CAGEC and part number.
XC –	Installation drawing, diagram, instruction sheet, field service drawings: identified by manufacturer’s part number.
XD -	Item is not stocked. Order an XD-coded item through normal supply channels using the CAGEC and part number given, if no NSN is available.

NOTE

Cannibalization or controlled exchange, when authorized, may be used as a source of supply for items with the above source codes, except for those Source coded “XA” or those aircraft support items restricted by requirements of AR 700-42.

2. Maintenance Code. Maintenance codes tell you the level(s) of maintenance authorized to use and repair support items. The maintenance codes are entered in the third and fourth positions of the SMR code as follows:

a. Third Position. The maintenance code entered in the third position tells you the lowest maintenance level authorized to remove, replace, and use an item. The maintenance code entered in the third position will indicate authorization to one of the following levels of maintenance:

Maintenance Code	Application/Explanation
C	Crew or operator maintenance done within unit/AVUM maintenance.
O	Unit level/AVUM maintenance can remove, replace and use the item.
F	Direct support/AVIM maintenance can remove, replace and use the item.
H	General support maintenance can remove, replace and use the item.
L	Specialized repair activity can remove, replace and use the item.
D	Depot can remove, replace and use the item.

TM 9-4910-783-13&P

b. Fourth Position. The maintenance code entered in the fourth position tells whether or not the item is to be repaired and identifies the lowest maintenance level with the capability to do complete repair (perform all authorized repair functions).

NOTE

Some limited repair may be done on the item at a lower level of maintenance, if authorized by the MAC and SMR codes.

Maintenance Code	Application/Explanation
O	Unit/AVUM is the lowest level that can do complete repair of the item.
F	Direct support/AVIM is the lowest level that can do complete repair of the item.
H	General support is the lowest level that can do complete repair of the item.
L	Specialized repair activity is the lowest level that can do complete repair of the item.
D	Depot is the lowest level that can do complete repair of the item.
Z	Nonreparable. No repair is authorized.
B	No repair is authorized. No parts or special tools are authorized for maintenance of "B" coded item. However, the item may be reconditioned by adjusting, lubricating, etc., at the user level.

3. Recoverability Code. Recoverability codes are assigned to items to indicate the disposition action on unserviceable items. The recoverability code is shown in the fifth position of the SMR code as follows:

Recoverability Code	Application/Explanation
Z	Nonreparable item. When unserviceable, condemn and dispose of the item at the level of maintenance shown in third position of SMR code.
O	Reparable item. When uneconomically repairable, condemn and dispose of the item at the unit level.
F	Reparable item. When beyond lower level repair capability, return to depot.
D	Condemnation and disposal of item not authorized below depot level.
L	Reparable item. Condemnation and disposal not authorized below Specialized Repair Activity (SRA).
A	Item requires special handling or condemnation procedures because of specific reasons (such as precious metal content, high dollar value, critical material, or hazardous material). Refer to appropriate manuals/directives for specific instructions.

TM 9-4910-783-13&P

- c. NSN [Column (3)]. The national stock number for the item is listed in this column.
- d. CAGEC [Column (4)]. The Commercial and Government Entity Code (CAGEC) is a five-digit code which is used to identify the manufacturer, distributor, or Government agency/activity that supplies the item.
- e. PART NUMBER [Column (5)]. Indicates the primary number used by the manufacturer (individual, company, firm, corporation, or Government activity), which controls the design and characteristics of the item by means of its engineering drawings, specifications, standards, and inspection requirements to identify an item or range of items.

NOTE

When you use an NSN to requisition an item, the item you receive may have a different part number from the number listed.

- f. DESCRIPTION AND USABLE ON CODE (UOC) [Column (6)]. This column includes the following information:
 - 1. The federal item name, and when required, a minimum description to identify the item.
 - 2. Part numbers of bulk materials are referenced in this column in the line entry to be manufactured or fabricated.
 - 3. The statement "END OF FIGURE" appears just below the last item description in Column 6 for a given figure in both Section II and Section III.

g. QTY [Column (7)]. The QTY (quantity per figure) column indicates the quantity of the item used in the breakout shown on the illustration/figure, which is prepared for a functional group, subfunctional group, or an assembly. A "V" appearing in this column instead of a quantity indicates that the quantity is variable and the quantity may vary from application to application.

EXPLANATION OF COLUMNS

National Stock Number (NSN) Index.

a. **STOCK NUMBER Column.** This column lists the NSN by National item identification number (NIIN) sequence. The NIIN consists of the last nine digits of the NSN

NSN (i.e., 5305-01-574-1476)	When using this column to locate an item, ignore the first four digits of the NSN. However, the complete NSN should be used when ordering items by stock number.
NIIN	

b. **FIG. Column.** This column lists the number of the figure where the item is identified/ located. The figures are in numerical order in Section II and Section III.

c. **ITEM Column.** The item number identifies the item associated with the figure listed in the adjacent FIG. column. This item is also identified by the NSN listed on the same line.

PART NUMBER INDEX. P/Ns in this index are listed by number in ascending alphanumeric sequence (vertical arrangement of letter and number combination which places the first letter or digit of each group in order a through z, followed by the numbers 0 through 9 and each following letter or digit in like order).

TM 9-4910-783-13&P

- a. **PART NUMBER Column.** Indicates the P/N assigned to the item.
- b. **FIG. Column.** This item number is the number assigned to the item as it appears in the figure referenced in the adjacent figure number column.
- c. **ITEM Column.** The item number is the number assigned to the item as it appears in the figure referenced in the adjacent figure number column.

SPECIAL INFORMATION.

Usable On Code (UOC). The Usable on codes are not used in this listing

HOW TO LOCATE REPAIR PARTS.

When National Stock Number or Part Number is Not Known.

- a. **First.** Using the table of contents, determine the assembly group or subassembly group to which the item belongs. This is necessary since figures are prepared for assembly groups and subassembly groups, and listings are divided into the same groups.
- b. **Second.** Find the figure covering the assembly group or subassembly group to which the item belongs.
- c. **Third.** Identify the item on the figure and note the number(s).
- d. **Fourth.** Look in RPSTL for the figure and item number. The NSNs and part numbers are on the same line as the associated item numbers.

When National Stock Number is Known.

- a. **First.** If you have the NSN, look in the STOCK NUMBER column of the NSN index. The NSN is arranged in NIIN sequence. Note the figure and item number next to the NSN.
- b. **Second.** Turn to the figure and item number. Verify that the item is the one you are looking for.

When Part Number is Known.

- a. **First.** If you have the P/N and not the NSN, look in the PART NUMBER column of the P/N index. Identify the figure and item number.
- b. **Second.** Look up the item on the figure in the applicable repair parts list.

INSTRUCTIONS FOR REQUISITIONING PARTS NOT IDENTIFIED BY NSN. When requisitioning parts not identified by National Stock Number, it is mandatory that the following information be furnished by the supply officer.

1. Commercial and Government Entity (CAGE) Code Number.
2. Manufacturer's Part Number - Exactly as listed herein.
3. Nomenclature - Exactly as listed herein, including dimensions if necessary.
4. Manufacturer's Model Number.
5. Manufacturer's Serial Number - (End Item).

TM 9-4910-783-13&P

REPAIR PARTS AND SPECIAL TOOLS LIST (RPSTL)

0053 00

6. Any additional information such as type, size, thread, frame number, and electrical characteristics.
7. If DD Form 1348 is used, fill in all blocks except 4, 5, 6, and Remarks field in accordance with AR 725-50.

Complete the form as follows:

1. Blocks 4, 5, and 6 - List Commercial and Government Entity Code Number followed by a colon and manufacturer's part number for the repair part.
2. Complete Remarks field as follows:

Noun: (Nomenclature of repair part)

For:

Manufacturer:

Model:

Serial Number of End Item:

Any additional information such as type, size, thread, frame number, dimensions, and electrical characteristics.

ABBREVIATIONS. The abbreviations that are used in the Repair Parts and Special Tools List Work Packages are explained below.

Abbreviation	Explanation
NIIN	National Item Identification Number (consists of the last nine digits of the NSN)
RPSTL	Repair Parts and Special Tools List
AP	Attachable Part

TM 9-4910-783-13&P



Figure 5-1. Group 00, Standard Automotive Tool Set (SATS) on Trailer

(1) ITEM NO.	(2) SMR CODE	(3) NSN	(4) CAGEC	(5) PART NUMBER	(6) DESCRIPTION AND USABLE ON CODE (UOC)	(7) QTY
					Group 00: SATS Figure 5-1. SATS	
1	XBOKK		00NS2	KTC-S 2000	Standard Automotive Tool Set with Trailer	1
END OF FIGURE						

TM 9-4910-783-13&P

REPAIR PARTS AND SPECIAL TOOLS LIST (RPSTL)

0053 00

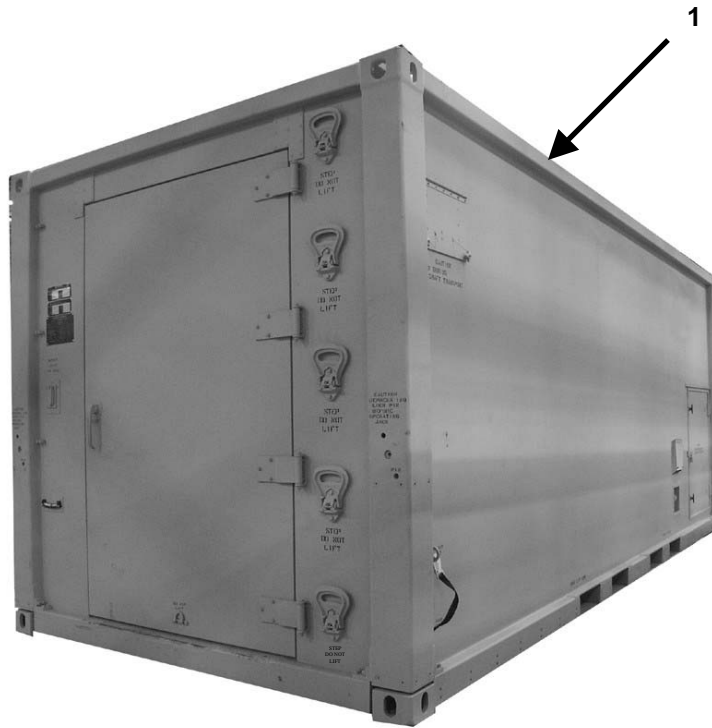

Figure 5-2. Group 01, Container, Standard Automotive Tool Set

(1) ITEM NO.	(2) SMR CODE	(3) NSN	(4) CAGEC	(5) PART NUMBER	(6) DESCRIPTION AND USABLE ON CODE (UOC)	(7) QTY
					Group 01: Container Figure 5-2. Container	
1	XBOKK		00NS2	KTC-S 1725	Container	1
					END OF FIGURE	

TM 9-4910-783-13&P

REPAIR PARTS AND SPECIAL TOOLS LIST (RPSTL)

0053 00

THIS PAGE INTENTIONALLY LEFT BLANK

TM 9-4910-783-13&P



Figure 5-3. Group 0101, Environmental Control Unit, End Wall (Sheet 1 of 2)

TM 9-4910-783-13&P

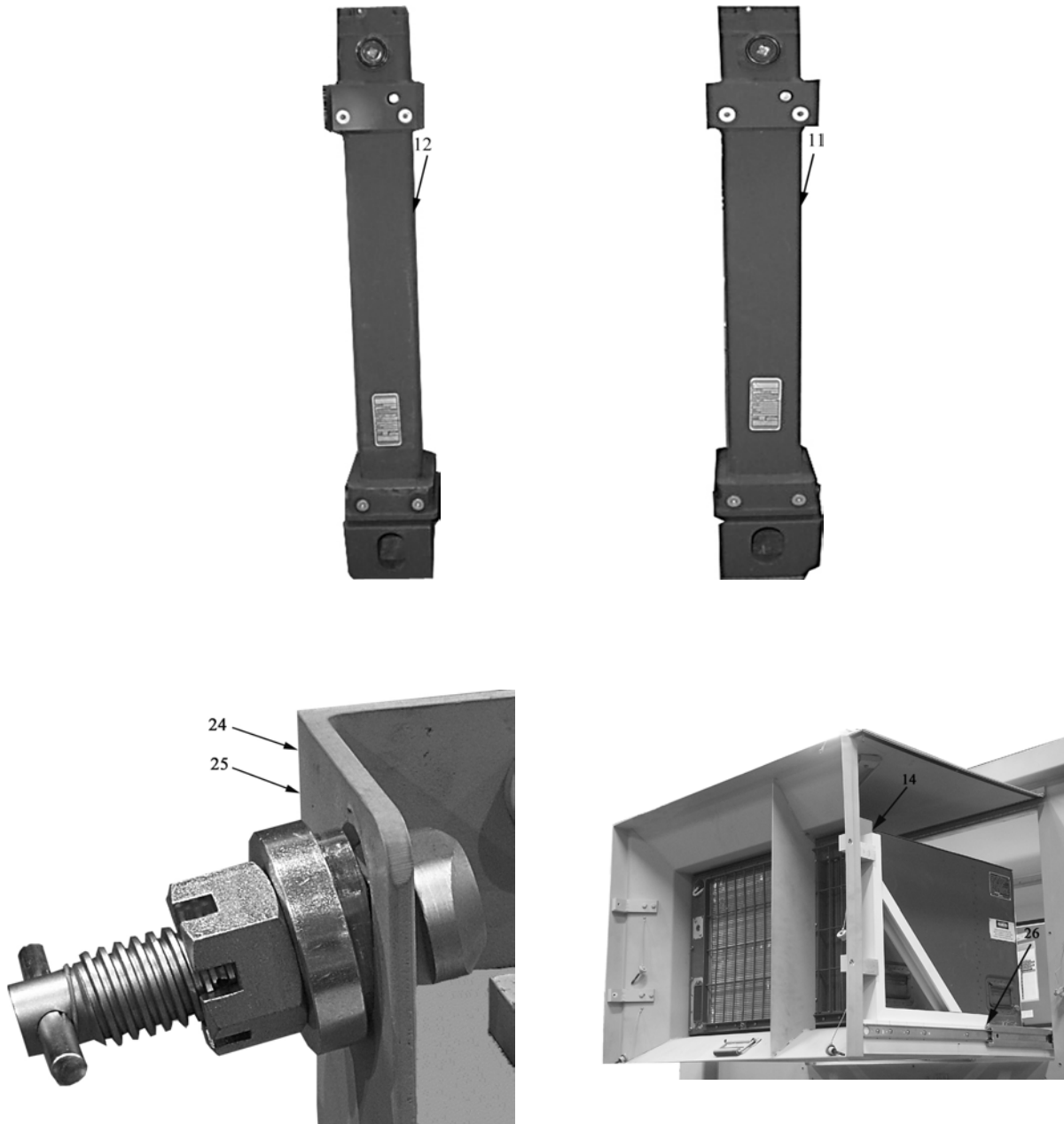

Figure 5-3. Group 0101, Environmental Control Unit, End Wall (Sheet 2 of 2)

TM 9-4910-783-13&P

REPAIR PARTS AND SPECIAL TOOLS LIST (RPSTL)

0053 00

(1) ITEM NO.	(2) SMR CODE	(3) NSN	(4) CAGEC	(5) PART NUMBER	(6) DESCRIPTION AND USABLE ON CODE (UOC)	(7) QTY
Group 0101: ECU End Wall Figure 5-3. ECU End Wall						
1	XBOOO		00NS2	KTC-S1714	ECU End Wall (Outside)	1
2	XAOOO		00NS2	KTC-S1726	ECU Access Panel Assembly	1
3	PAOOO		00NS2	KTC-S0015	Prop Rod Assembly	1
4	PAOOO		00NS2	KTC-S0017	Mounting Block	1
5	PAOZZ		00NS2	KTC-S1727	Cap Screw	1
6	PAOZZ		00NS2	KTC-S0016	Prop Rod	1
7	PAOZZ		00NS2	KTC-S1681	Seal	1
8	PAOZZ		00NS2	KTC-S0014	Lanyard	5
9	PAOZZ		00NS2	KTC-S0012	Thumbscrew (External)	5
10	PAOZZ		00NS2	KTC-S0018	Spring Clip	2
11	PAOZZ		00NS2	KTC-S0002	Jack Assembly (Left)	1
12	PAOZZ		00NS2	KTC-S0001	Jack Assembly (Right)	1
13	PAOZZ		00NS2	KTC-S1671	Shroud, (External)	1
14	PAOZZ		00NS2	KTC-S1684	External Seal	1
15	PAOOO		00NS2	KTC-S0047	Exterior Outlet Assembly	1
16	PAOZZ		00NS2	KTC-S1730	Cover with Seal	1
17	PAOZZ		00NS2	KTC-S1731	Receptacle	1
18	XAOZZ		00NS2	KTC-S1732	Housing	1
19	PAOZZ		00NS2	KTC-S1733	Retaining Clip (External Light)	3
20	PAOZZ		00NS2	KTC-S1669	Door Exhaust, Air Assembly	1
21	PAOZZ		00NS2	KTS-S1667	Gusset, Bridge Plate	2
22	PAOZZ		00NS2	KTC-S1666	Gusset, Jack Plate	4
23	PAOZZ		00NS2	KTC-S1756	Screw Socket Head Screw	8
24	PAOZZ		00NS2	KTC-S0004	Right, ISO Spacer Block with T-Lock	1
25	PAOZZ		00NS2	KTC-S1757	Left, ISO Spacer Block with T-Lock	1
26	PAOZZ		00NS2	KTC-S0019	ECU Slide Assembly	1

END OF FIGURE

TM 9-4910-783-13&P

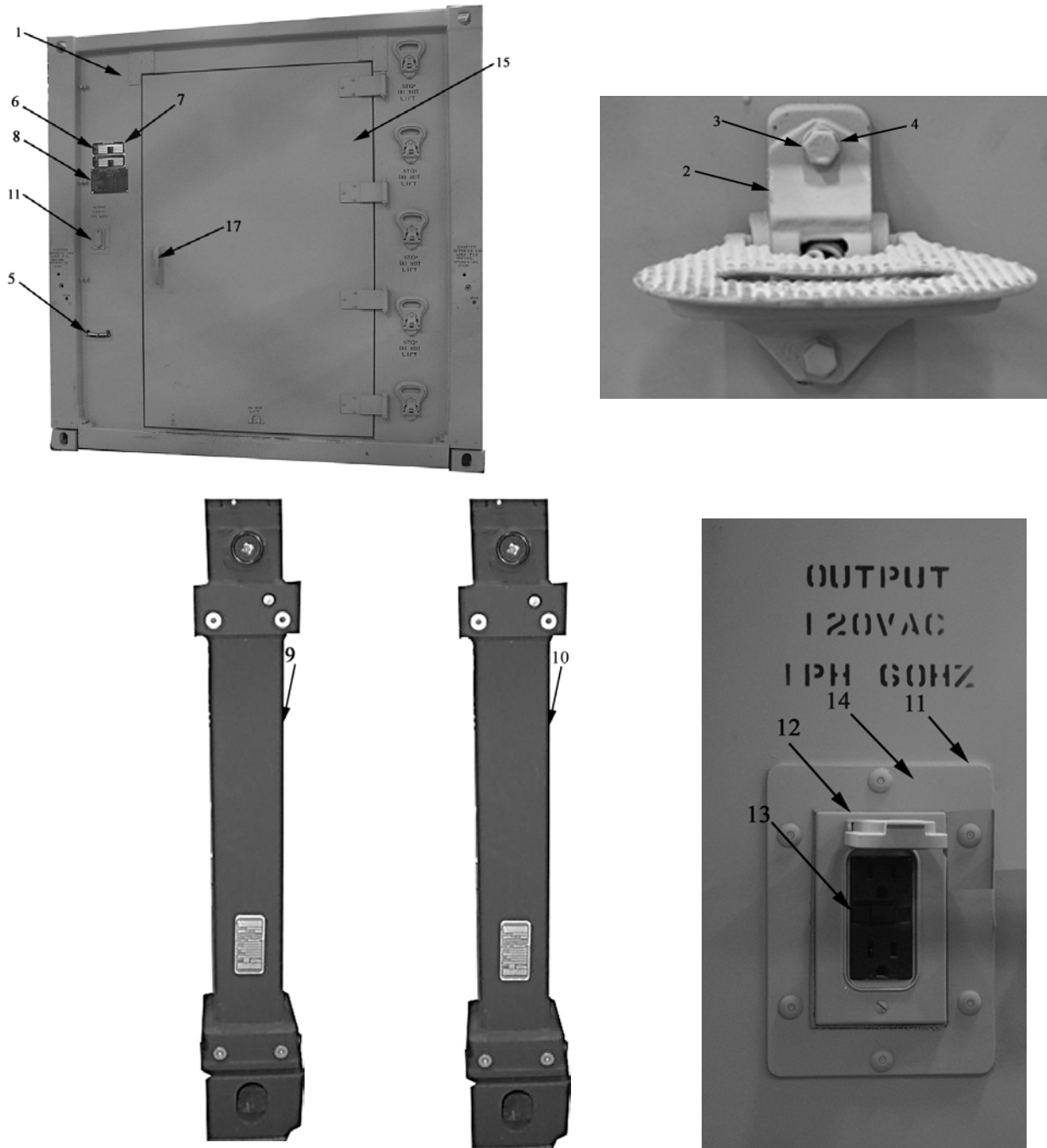

Figure 5-4. Group 0201, Outside Personnel End Wall (Sheet 1 of 3)

TM 9-4910-783-13&P

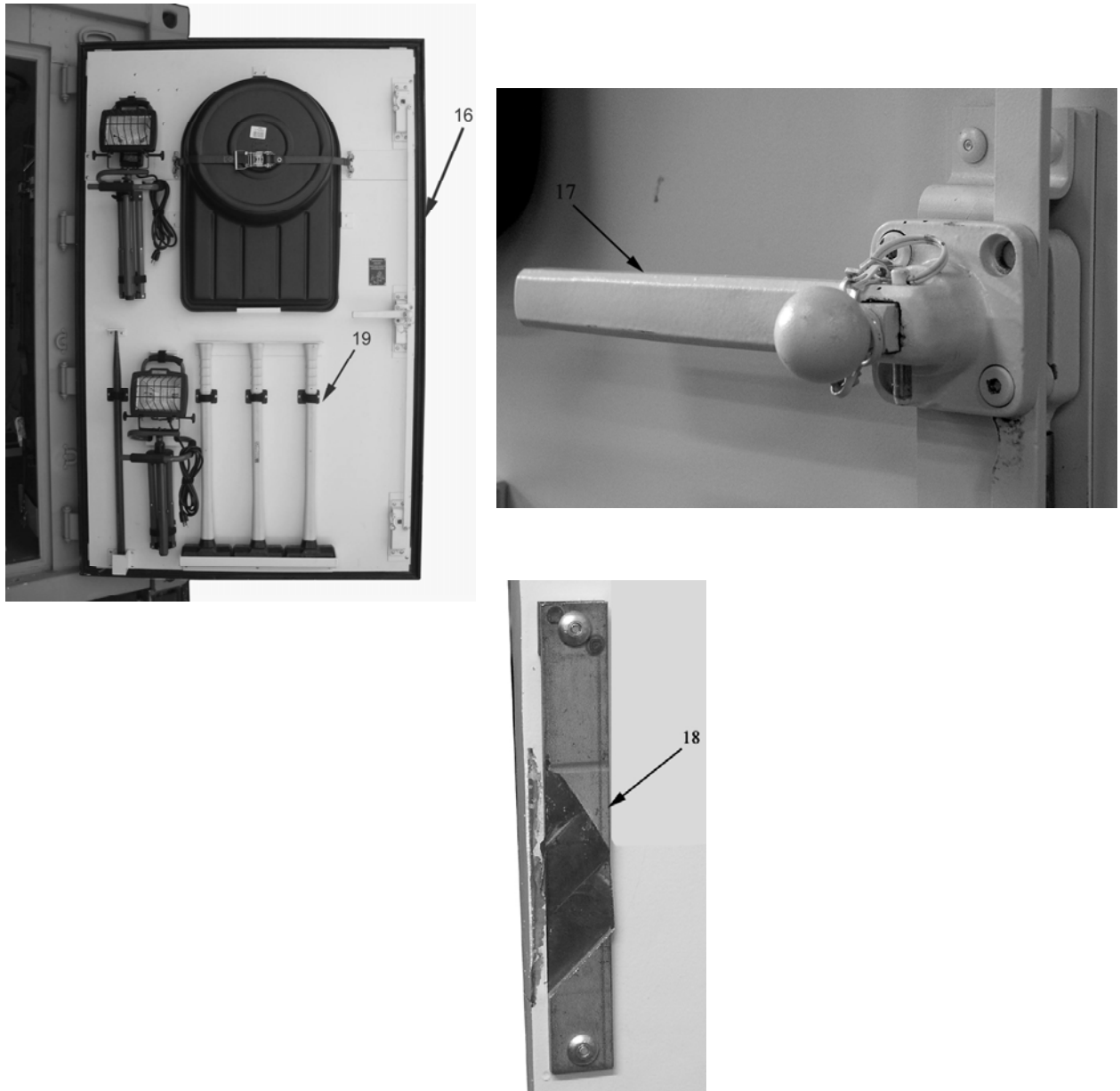

Figure 5-4. Group 0201, Outside Personnel End Wall (Sheet 2 of 3)

TM 9-4910-783-13&P

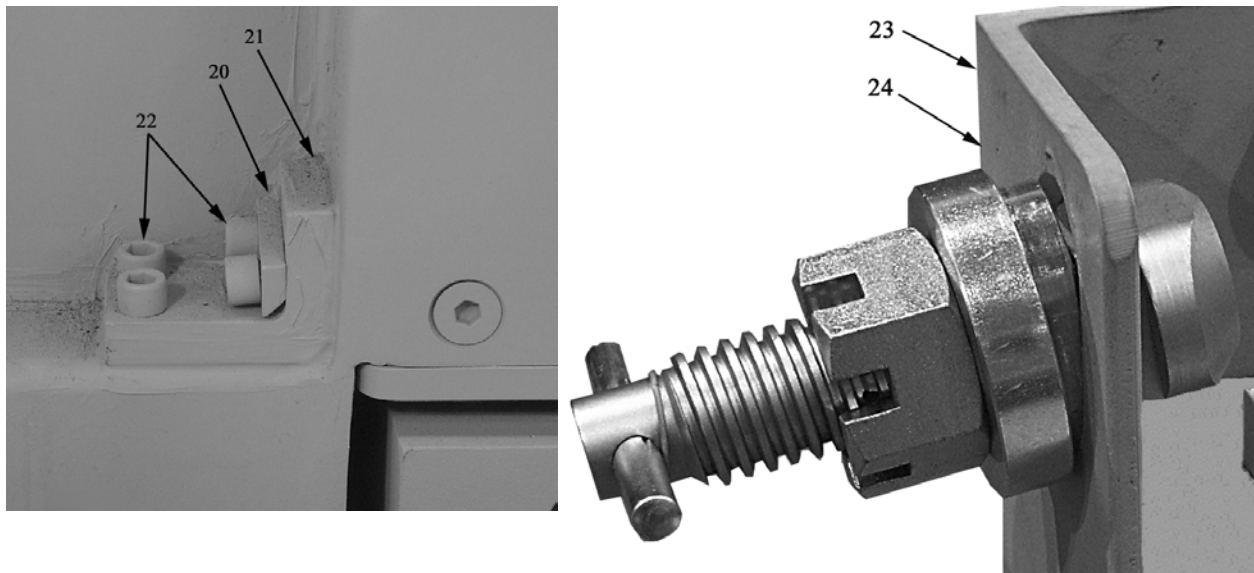

Figure 5-4. Group 0201, Outside Personnel End Wall (Sheet 3 of 3)

(1) ITEM NO.	(2) SMR CODE	(3) NSN	(4) CAGEC	(5) PART NUMBER	(6) DESCRIPTION AND USABLE ON CODE (UOC)	(7) QTY
Group 0201: Outside Personnel End Wall						
Figure 5-4. Outside Personnel End Wall						
1	XAOOO		00NS2	KTC-S1713	Outside Personnel End Wall	1
2	PAOOO		00NS2	KTC-S0049	Step	5
3	PAOZZ		00NS2	KTC-S0028	Cap Screw	2
4	PAOZZ		00NS2	KTC-S1718	Lock Washer	2
5	PAOZZ		00NS2	KTC-S0038	Inclinometer	1
6	PAOOO		00NS2	KTC-S1734	Data Plate (Kipper)	1
7	PAOZZ		00NS2	KTC-S1736	Self-Taping Screw	4
8	PAOZZ		00NS2	KTC-S1735	Data Plate (CSC)	1
9	PAOZZ		00NS2	KTC-S0002	Jack Assembly (Left)	1
10	PAOZZ		00NS2	KTC-S0001	Jack Assembly (Right)	1
11	PAOOO		00NS2	KTC-S0047	110V Exterior Outlet Assembly	1
12	PAOZZ		00NS2	KTC-S1730	Cover	1
13	PAOZZ		00NS2	KTC-S1731	Receptacle	1
14	XAOZZ		00NS2	KTC-S1732	Housing	1
15	PAOOO		00NS2	KTC-S0039	Personnel Door Assembly	1
16	PAOZZ		00NS2	KTC-S0046	Seal	1
17	PAOZZ		00NS2	KTC-S0042	Handle Assembly	1
18	PAOZZ		00NS2	KTC-S1682	Strike Plate	3
19	PAOZZ		00NS2	KTC-S1689	Velcro Straps	8
20	PAOZZ		00NS2	KTS-S1667	Gusset, Bridge Plate	2
21	PAOZZ		00NS2	KTC-S1666	Gusset, Jack Plate	4
22	PAOZZ		00NS2	KTC-S1756	Screw Socket Head Screw	8
23	PAOZZ		00NS2	KTC-S0004	Left, ISO Spacer Block with T-Lock	1
24	PAOZZ		00NS2	KTC-S1757	Right, ISO Spacer Block with T-Lock	1

END OF FIGURE

TM 9-4910-783-13&P

REPAIR PARTS AND SPECIAL TOOLS LIST (RPSTL)

0053 00

THIS PAGE INTENTIONALLY LEFT BLANK

TM 9-4910-783-13&P

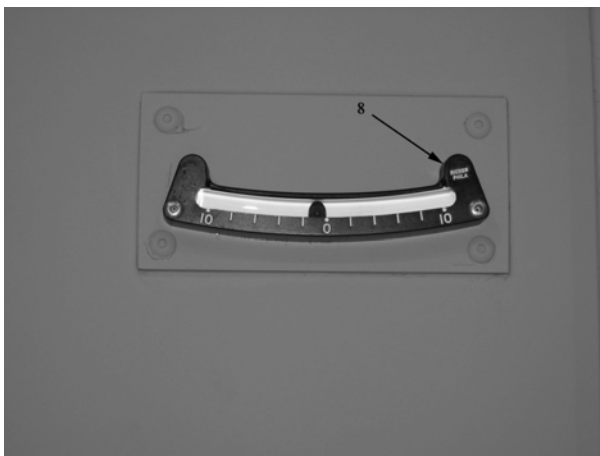
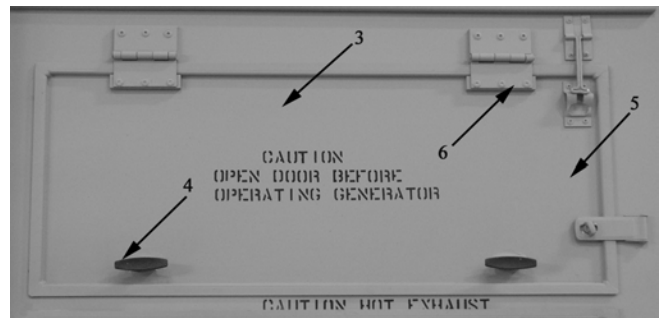
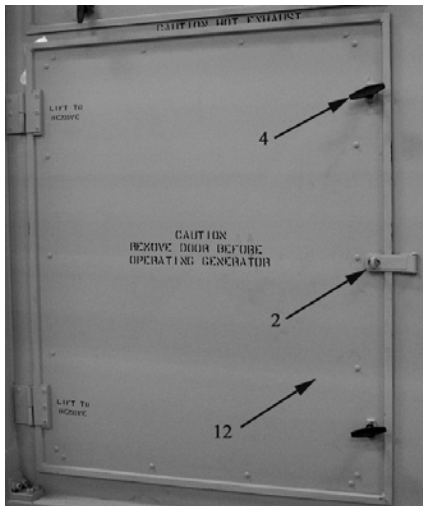

Figure 5-5. Group 0301, Left-hand Side Wall (Outside)

TM 9-4910-783-13&P

REPAIR PARTS AND SPECIAL TOOLS LIST (RPSTL)

0053 00

(1) ITEM NO.	(2) SMR CODE	(3) NSN	(4) CAGEC	(5) PART NUMBER	(6) DESCRIPTION AND USABLE ON CODE (UOC)	(7) QTY
					Group 0301: Wall, Left (Outside) Figure 5-5. Wall, Left (Outside)	
1	XAOOO		00NS2	KTC-S1716	Left Hand Sidewall (Outside)	1
2	PAOZZ		00NS2	KTC-S0050	Hasp, Locking	2
3	PAOOO		00NS2	KTC-S0064	Generator Exhaust Panel Assembly	1
4	PAOZZ		00NS2	KTC-S0052	T-Handle	4
5	XAOZZ		00NS2	KTC-S1737	Door	1
6	PAOZZ		00NS2	KTC-S1668	Hinge Door	3
7	PAOZZ		00NS2	KTC-S0048	Detent Rail Rivnut	42
8	PAOZZ		00NS2	KTC-S0038	Inclinometer	1
9	PAOZZ		00NS2	KTC-S1756	Gusset Bridge Plate	2
10	PAOZZ		00NS2	KTC-S1666	Gusset Jack Plate	2
11	PAOZZ		00NS2	KTC-S1757	Screw Socket Head Screw	8
12	PAOOO		00NS2	KTC-S0064	Generator Access Door	1

END OF FIGURE

TM 9-4910-783-13&P

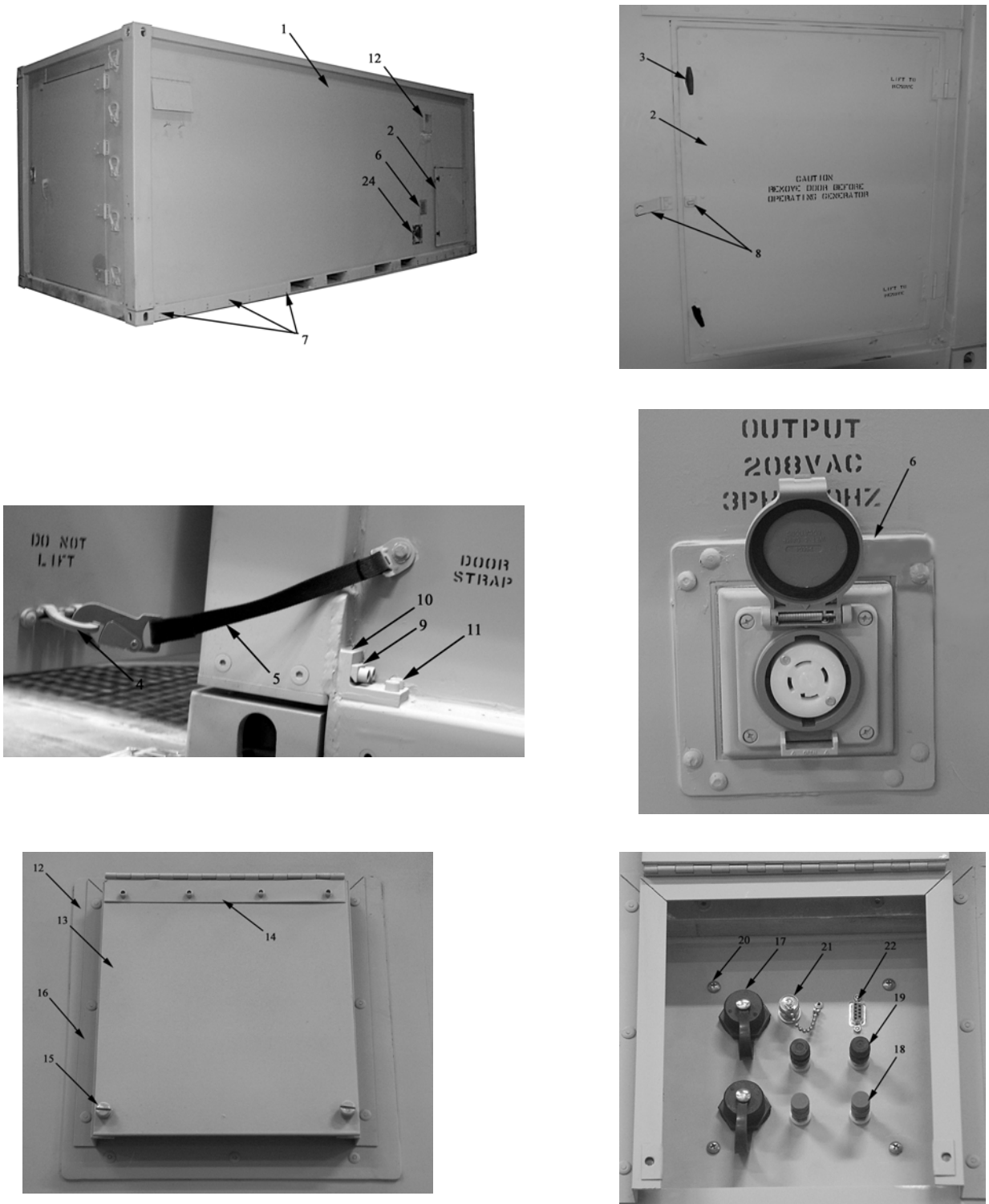

Figure 5-6. Group 0401, Right-hand Sidewall (Outside) (Sheet 1 of 2)

TM 9-4910-783-13&P

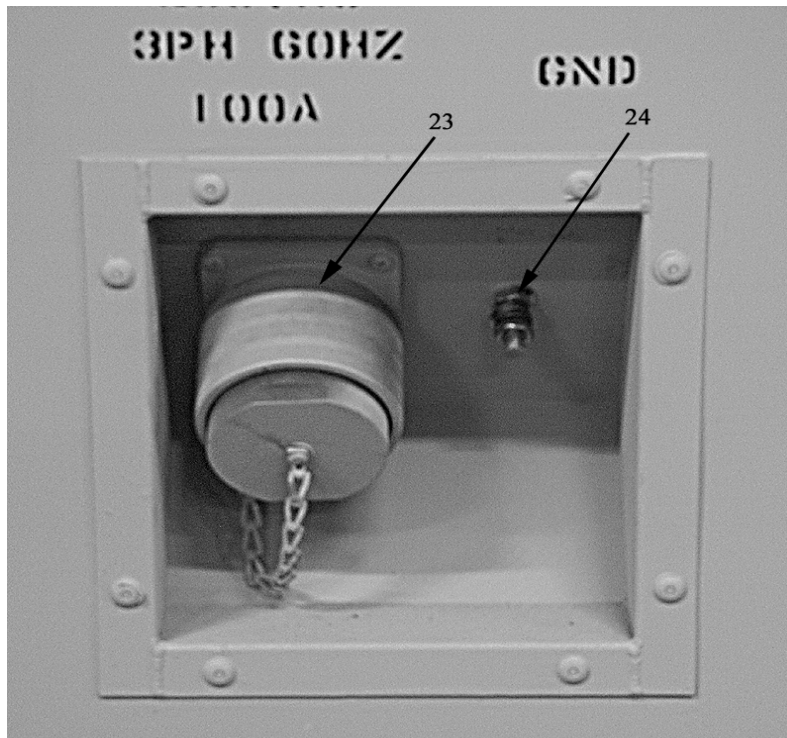

Figure 5-6. Group 0401, Right-hand Sidewall (Outside) (Sheet 2 of 2)

(1) ITEM NO.	(2) SMR CODE	(3) NSN	(4) CAGEC	(5) PART NUMBER	(6) DESCRIPTION AND USABLE ON CODE (UOC)	(7) QTY
Group 0401: Wall, Right (Outside) Figure 5-6. Wall, Right (Outside)						
1	XAOOO		00NS2	KTC-S1710	Right Hand Side Wall (Outside)	1
2	PAOOO		00NS2	KTC-S0063	Generator Access Door	1
3	PAOZZ		00NS2	KTC-S0052	T-Handle	2
4	PAOZZ		00NS2	KTC-S0113	D-Ring, Tie Down	1
5	PAOZZ		00NS2	KTC-S0046	Strap, Tie Down	1
6	PAOZZ		00NS2	KTC-S0071	220V External Outlet Assembly	1
7	PAOZZ		00NS2	KTC-S0048	Detent Rail Rivnut	42
8	PAOZZ		00NS2	KTC-S0050	Hasp, Locking	1
9	PAOZZ		00NS2	KTC-S1756	Gusset Bridge Plate	2
10	PAOZZ		00NS2	KTC-S1666	Gusset Jack Plate	4
11	PAOZZ		00NS2	KTC-S1757	Screw Socket Head Screw	8
12	PAOOO		00NS2	KTC-S0090	Communications Panel Assembly	1
13	XAOOO		00NS2	KTC-S1738	Door	1
14	PAOZZ		00NS2	KTC-S1668	Hinge	1
15	PAOZZ		00NS2	KTC-S0093	Thumbscrew	2
16	XAOOO		00NS2	KTC-S1739	Housing, (Outside)	1
17	PAOZZ		00NS2	KTC-S0089	Connector, RJ 45	2
18	PAOZZ		00NS2	KTC-S0085	Binding Post (RED)	2
19	PAOZZ		00NS2	KTC-S0086	Binding Post (BLACK)	2
20	PAOZZ		00NS2	KTC-S1740	Screw	4
21	PAOZZ		00NS2	KTC-S0087	BNC Connector	1
22	PAOZZ		00NS2	KTC-S1741	Serial Port	1
23	PAOZZ		00NS2	KTC-S0036	Pan Power Input Receptacle Assembly	1
24	PAOZZ		00NS2	KTC-S1766	Grounding Stud, Container	1

END OF FIGURE

TM 9-4910-783-13&P

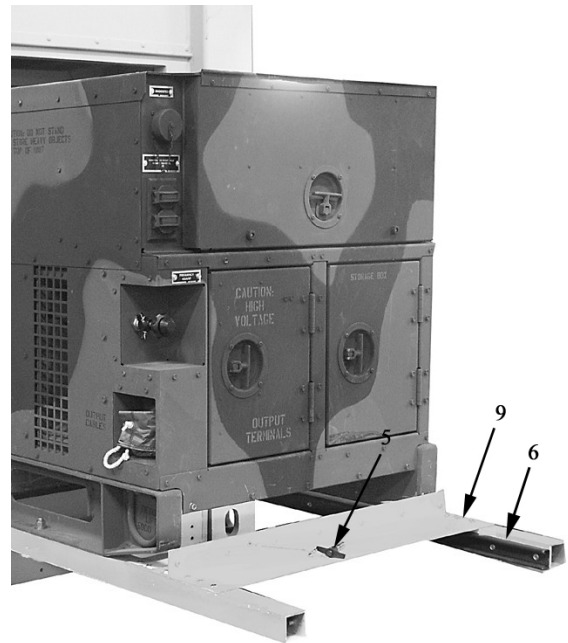
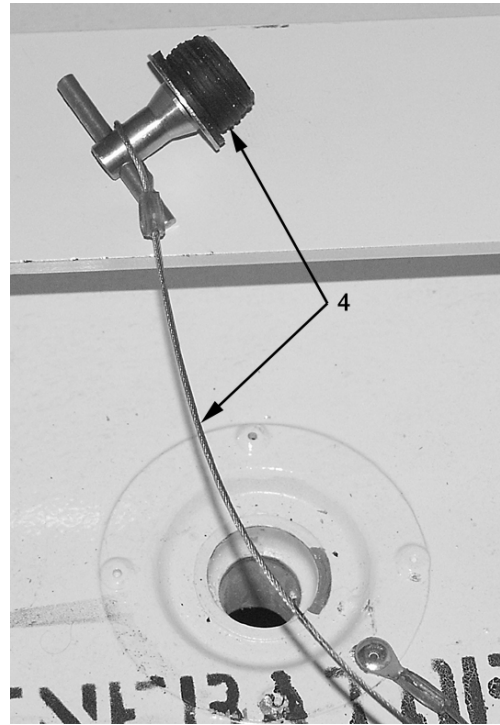

Figure 5-7. Group 0501, Mechanical Room

TM 9-4910-783-13&P

REPAIR PARTS AND SPECIAL TOOLS LIST (RPSTL)

0053 00

(1) ITEM NO.	(2) SMR CODE	(3) NSN	(4) CAGEC	(5) PART NUMBER	(6) DESCRIPTION AND USABLE ON CODE (UOC)	(7) QTY
Group 0501: Mechanical Room Figure 5-7. Mechanical Room						
1	XA000		00NS2	KTC-S1767	Mechanical Room	1
2	PA000		00NS2	KTC-S0029	Strap, Safety	2
3	PA0ZZ		00NS2	KTC-S0028	Cap Screw	4
4	PA0ZZ		00NS2	KTC-S0035	Drain Plug, Floor, with Lanyard	1
5	PA0ZZ		00NS2	KTC-S0027	T-Pin, with Lanyard	1
6	PA000		00NS2	KTC-S0023	Generator Slide Assembly	1
7	PA0ZZ		00NS2	KTC-S0024	Upper Rail Assembly	1
8	PA000		00NS2	KTC-S0025	Lower Rail Assembly	1
9	PA0ZZ		00NS2	KTC-S0026	Caster	62

END OF FIGURE

TM 9-4910-783-13&P

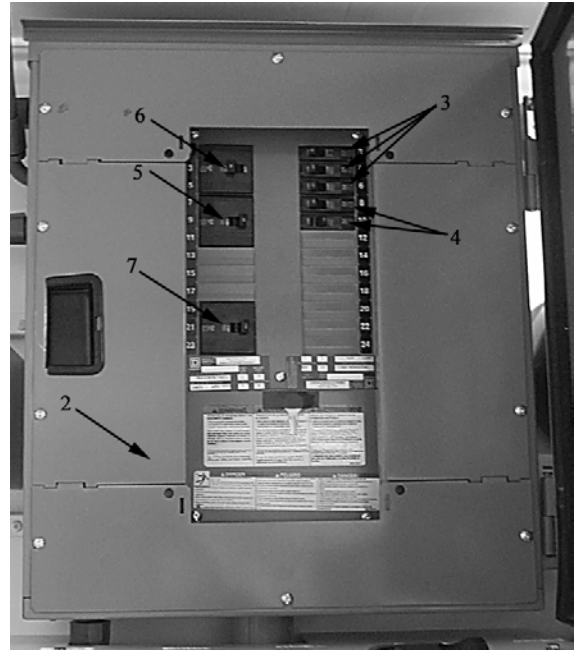

Figure 5-8. Group 0701, Right-hand Wall (Inside)

TM 9-4910-783-13&P

REPAIR PARTS AND SPECIAL TOOLS LIST (RPSTL)

0053 00

(1) ITEM NO.	(2) SMR CODE	(3) NSN	(4) CAGEC	(5) PART NUMBER	(6) DESCRIPTION AND USABLE ON CODE (UOC)	(7) QTY
					Group 0701: Wall, Right (Inside) Figure 5-8. Wall, Right (Inside)	
1	XA000		00NS2	KTC-S1710	Right Hand Wall (Inside)	1
2	PA000		00NS2	KTC-S1672	Circuit Breaker Assembly	1
3	PA0ZZ		00NS2	KTC-S0096	Circuit Breaker, 20 AMP	3
4	PA0ZZ		00NS2	KTC-S0097	Circuit Breaker, 15 AMP	2
5	PA0ZZ		00NS2	KTC-S0095	Circuit Breaker, 3PH 30 AMP	1
6	PA0ZZ		00NS2	KTC-S0094	Circuit Breaker, 3PH 100 AMP	1
7	PA0ZZ		00NS2	KTC-S1742	Circuit Breaker, 3PH 20 AMP	1
8	PA0ZZ		00NS2	KTC-S1758	Rack Assembly, (L)	1
9	PA0ZZ		00NS2	KTC-S1759	Rack Assembly, (K)	1
10	PA0ZZ		00NS2	KTC-S1760	Rack Assembly, (J)	1
11	PA0ZZ		00NS2	KTC-S1761	Rack Assembly, (H)	1
12	PA0ZZ		00NS2	KTC-S1762	Rack Assembly, (G)	1

END OF FIGURE

TM 9-4910-783-13&P

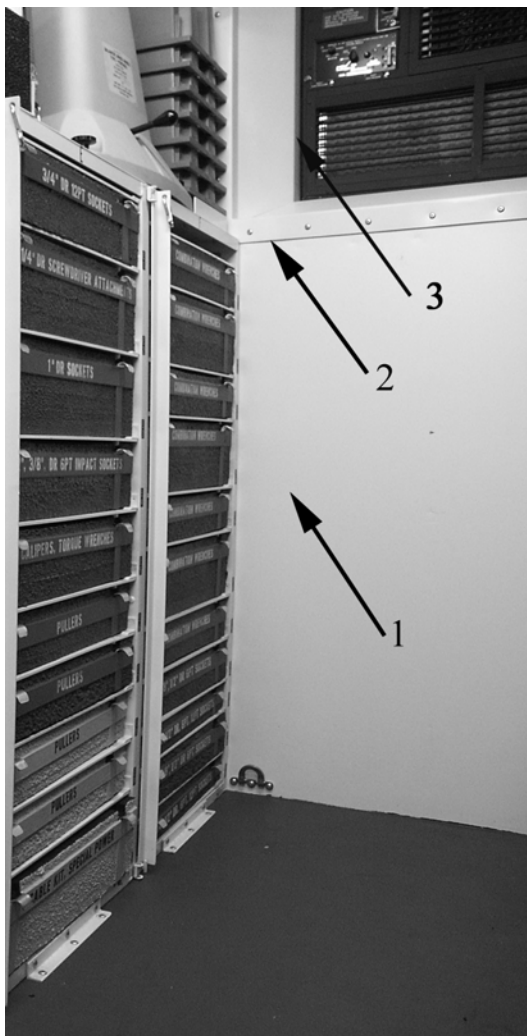

Figure 5-9. Group 0801, Mechanical Room Wall (Inside)

(1) ITEM NO.	(2) SMR CODE	(3) NSN	(4) CAGEC	(5) PART NUMBER	(6) DESCRIPTION AND USABLE ON CODE (UOC)	(7) QTY
Group 0801: Mechanical Room Wall (Inside)						
Figure 5-9. Mechanical Room Wall (Inside)						
1	XAOOO		00NS2	KTC-S1715	Mechanical Room Wall (Inside)	1
2	PAOZZ		00NS2	KTC-S1742	Shroud, Internal ECU	1
3	PAOZZ		00NS2	KTC-S1685	Seal	1

END OF FIGURE

TM 9-4910-783-13&P



Figure 5-10. Group 0901, Left-hand Wall (Inside)

(1) ITEM NO.	(2) SMR CODE	(3) NSN	(4) CAGEC	(5) PART NUMBER	(6) DESCRIPTION AND USABLE ON CODE (UOC)	(7) QTY
Group 0901: Wall, Left (Inside) Figure 5-10. Wall, Left (Inside)						
1	XAOOO		00NS2	KTC-S1716	Left-hand Wall (Inside)	1
2	PAOZZ		00NS2	KTC-S1763	Rack Assembly (F)	1
3	PAOZZ		00NS2	KTC-S1764	Rack Assembly (E)	1
4	PAOZZ		00NS2	KTC-S1765	Rack Assembly (D)	1

END OF FIGURE

TM 9-4910-783-13&P

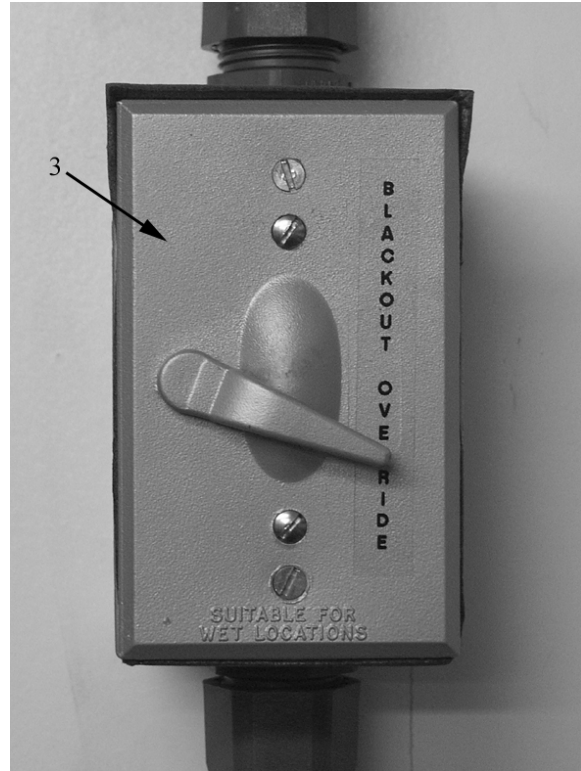
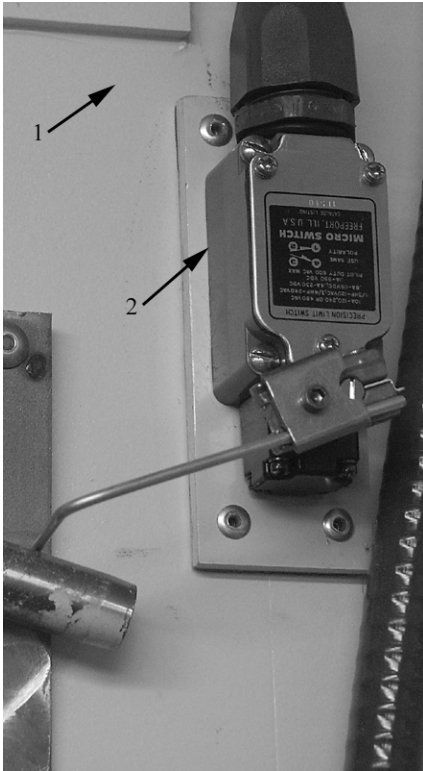

Figure 5-11. Group 0110, Door Entry Wall (Inside)

TM 9-4910-783-13&P

REPAIR PARTS AND SPECIAL TOOLS LIST (RPSTL)
0053 00

(1) ITEM NO.	(2) SMR CODE	(3) NSN	(4) CAGEC	(5) PART NUMBER	(6) DESCRIPTION AND USABLE ON CODE (UOC)	(7) QTY
					Group 0110: Door Entry Wall (Inside) Figure 5-11. Door Entry Wall (Inside)	
1	XAOOO		00NS2	KTC-S1713	Door Entry Wall, (Inside)	1
2	PAOZZ		00NS2	KTC-S0111	Blackout Limit Switch Assembly	1
3	PAOZZ		00NS2	KTC-S0110	Blackout Override Switch Assembly	1
4	PAOZZ		00NS2	KTC-S0074	Light Switch Assembly	1

END OF FIGURE

TM 9-4910-783-13&P



Figure 5-12. Group 0111, Floor

(1) ITEM NO.	(2) SMR CODE	(3) NSN	(4) CAGEC	(5) PART NUMBER	(6) DESCRIPTION AND USABLE ON CODE (UOC)	(7) QTY
Group 0111: Floor Figure 5-12. Floor						
1	XAOOO		00NS2	KTC-S1712	Floor	1
2	PAOZZ		00NS2	KTC-S0113	D-Ring, Tie-Down	1
END OF FIGURE						

TM 9-4910-783-13&P

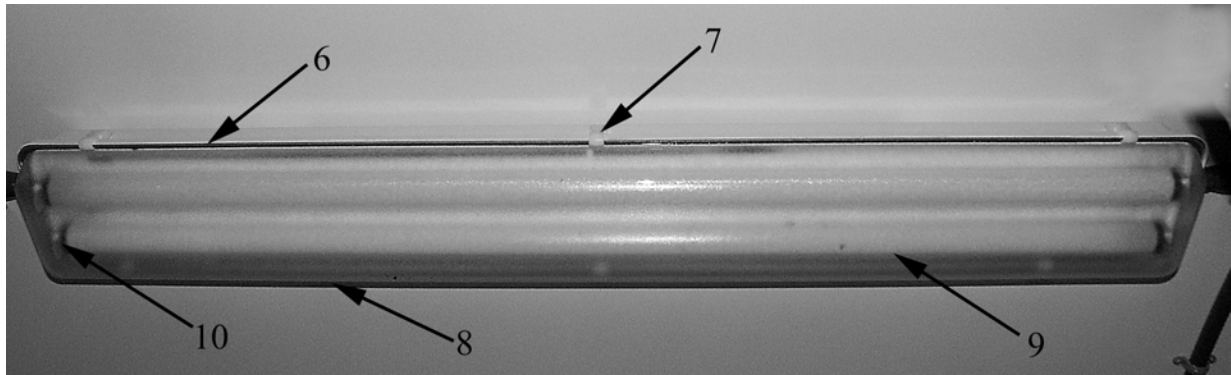
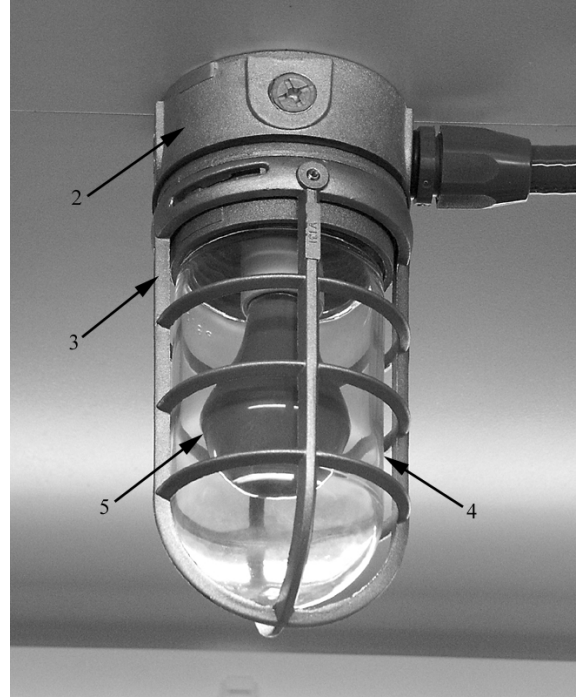

Figure 5-13. Group 0112, Ceiling (Sheet 1 of 2)

TM 9-4910-783-13&P

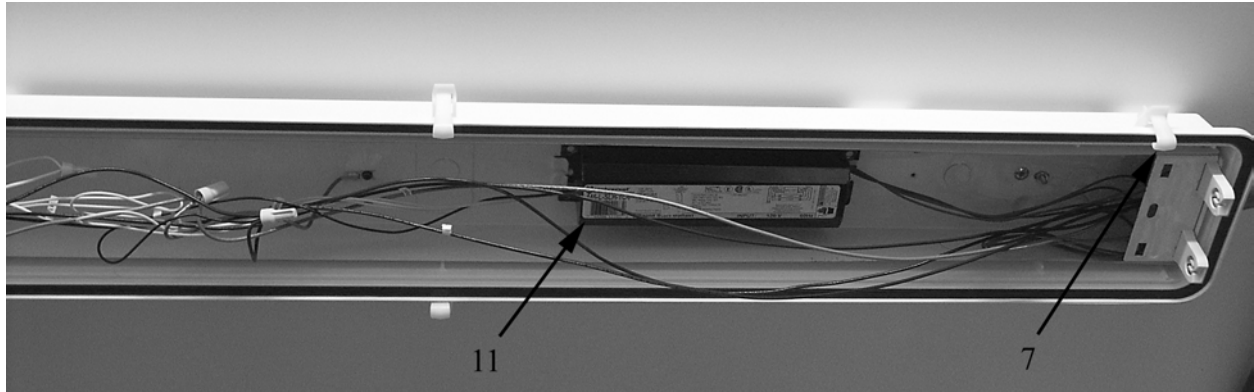

Figure 5-13. Group 0112, Ceiling (Sheet 2 of 2)

TM 9-4910-783-13&P

REPAIR PARTS AND SPECIAL TOOLS LIST (RPSTL)
0053 00

(1) ITEM NO.	(2) SMR CODE	(3) NSN	(4) CAGEC	(5) PART NUMBER	(6) DESCRIPTION AND USABLE ON CODE (UOC)	(7) QTY
Group 0112: Ceiling						
Figure 5-13. Ceiling						
1	XA000		00NS2	KTC-S1711	Ceiling	1
2	PA000		00NS2	KTC-S0106	Light Assembly, Blackout	2
3	PA0ZZ		00NS2	KTC-S1706	Guard	2
4	PA0ZZ		00NS2	KTC-S1707	Dome Glass	2
5	PA0ZZ		00NS2	KTC-S0107	Bulb	2
6	PA000		00NS2	KTC-S1670	Light Assembly, Fluorescent	3
7	PA0ZZ		00NS2	KTC-S1703	Lens, Retaining Clip	18
8	PA0ZZ		00NS2	KTC-S1704	Lens	3
9	PA0ZZ		00NS2	KTC-S0054	Fluorescent Light Bulb	6
10	PA0ZZ		00NS2	KTC-S1702	Bulb Retaining Clip	12
11	PA0ZZ		00NS2	KTC-S1705	Cold Weather Ballast	3
12	PA0ZZ		00NS2	KTC-S0047	120V Electrical Outlet Assembly	6

END OF FIGURE

TM 9-4910-783-13&P

REPAIR PARTS AND SPECIAL TOOLS LIST (RPSTL)

0053 00

CONSUMABLES

(1) ITEM NUMBER	(2) NATIONAL STOCK NUMBER	(3) DESCRIPTION	(4) U / M
1	KTC S0200	FILE SET, HAND, HALF RD., BAS, 12"	
2	KTC S0276	SAW, HAND, CROSSCUT	
3	KTC-S1495	BLADE, HACKSAW, HAND	
4	KTC-S0277	SAW, HAND, METAL CTG, CLOSE QTR	
5	KTC-S0278	SAW, HAND, METAL CUTTING	
6	KTC-S0183	CUTTER, BOLT, REPLACEMENT HEAD	
7	KTC-S0194	DRILL SET, TWIST	
8	KTC-S0195	DRILL SET, TWIST, LEFT HAND	
9	KTC-S0148	BRUSH, WIRE, SCRATCH	
10	KTC-S0147	BRUSH, WIRE, ROT, END ATT., CIR, SIDE FL.	
11	KTC-S0146	BRUSH, WIRE, ROT, END ATT., SOLID WIRE	
12	KTC-S0145	BRUSH, FILE CLEANER	
13	KTC-S0140	BLADE HAND HACKSAW	
14	KTC-S0141	BLADE ABRASIVE, CUT OFF	
15	KTC-S0126	APRON, UTILITY	
16	KTC-S0208	GLOVES, RUBBER	

TM 9-4910-783-13&P

PARTS LIST ORDER FORM

0054 00

TM 9-4910-783-13&P Standard Automotive Tool Set Parts Order Form

Email to _____ Fax to _____

From	
Name	
Organization	
Address	
Phone #	
Fax #	
Email	
<i>(Expect response within 24-hour normal workday)</i>	

Shipping Information (check one)		Charge to:	
<input type="checkbox"/> CONUS	<input type="checkbox"/> OCONUS	<input type="checkbox"/> VISA	<input type="checkbox"/> MasterCard
		<input type="checkbox"/> American Express	<input type="checkbox"/> Government
Priority Designator		Card #	
		Exp. Date	
Required Delivery Date		<i>(Charges will include shipping cost)</i>	

SHIP TO (if different from above)			
Name		Phone #	
Organization			
DODAAC			
Customer Document Number (CDN)			

FORWARD TO (if appropriate)			
Name		DODAAC	
Organization			
Address			

Parts List #	Quantity	Description

END OF WORK PACKAGE

TM 9-4910-783-13&P

The supply officer shall identify the prime manufacturer of the repair part by Commercial and Government Entity (CAGE) Code Number and requisition the repair part from the prime manufacturer. When requisitioning parts from commercial sources, it is mandatory that the following information be provided the supply officer by the unit:

1. Commercial and Government Entity (CAGE) Code Number.
2. Manufacturer's Part Number – Exactly as listed in the commercial literature.
3. Nomenclature – Exactly as listed in the commercial literature, including dimensions if available.
4. Manufacturer's Model Number.
5. Manufacturer's Serial Number – (End Item).
6. Any additional information such as type, size, thread, frame number, and electrical characteristics.

END OF WORK PACKAGE

TM 9-4910-783-13&P

SCOPE

This work package lists components of end item and basic issue items for the Standard Automotive Tool Set to help you inventory items required for safe and efficient operation.

GENERAL

The Components of End Item and Basic Issue Item information is divided into the following lists:

a. Components of End Item. This listing is for informational purposes only, and is not authority to requisition replacements. These items are part of the end item, but are removed and separately packaged for transportation or shipment. As part of the end item, these items must be with the end item whenever it is issued or transferred between property accounts. Illustrations are furnished to assist you in identifying the items.

b. Basic Issue Items. These are the minimum essential items required to place the Standard Automotive Tool Set in operation, to operate, and to perform emergency repairs. Although shipped separately, BII must be with the tool set during operation and whenever they are transferred between property accounts. The illustrations will assist you with hard-to-identify items. This manual is your authority to request/requisition replacement BII, based on TOE/MTOE authorization, of the end item.

EXPLANATION OF COLUMNS

The following provides an explanation of columns found in the tabular listings:

- a. Column (1) – Illustration Number (Illus Number). This column indicates the number of the illustration in which the item is shown.
- b. Column (2) – National Stock Number. Indicates the National stock number assigned to the item and will be used for requisitioning purposes.
- c. Column (3) – Description. Indicates the Federal item name and, if required, a minimum description to identify and locate the item. The last line for each item indicates the FSCM (in parentheses) followed by the part number.
- d. Column (4) – Unit of Measure (U/M). Indicates the measure used in performing the actual operational/maintenance function. This measure is expressed by a two-character alphabetical abbreviation (e.g., ea, in, pr).
- e. Column (5) – Quantity required (Qty rqr). Indicates the quantity of the item authorized to be used with/on the equipment.

TM 9-4910-783-13&P

COMPONENTS OF END ITEM (COEI) AND BASIC ISSUE ITEMS (BII) LISTS

0056 00

COMPONENTS OF END ITEM (COEI) LIST

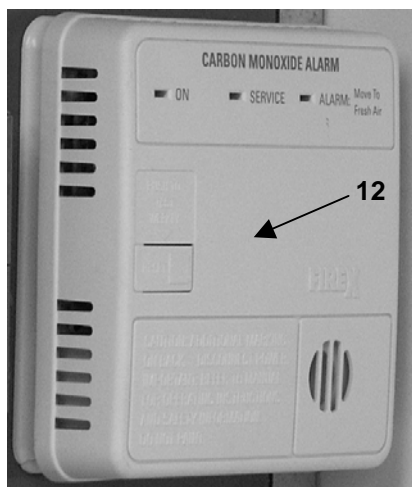
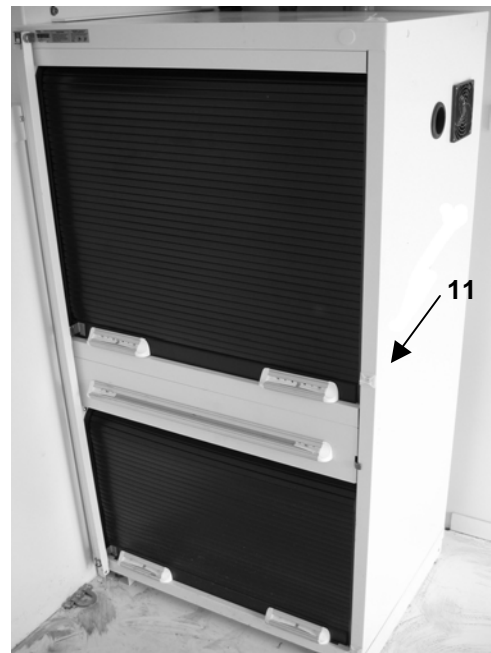
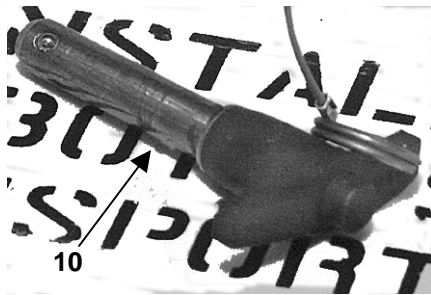
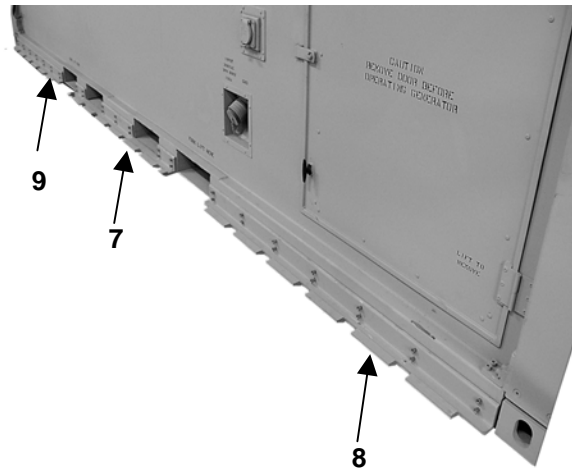
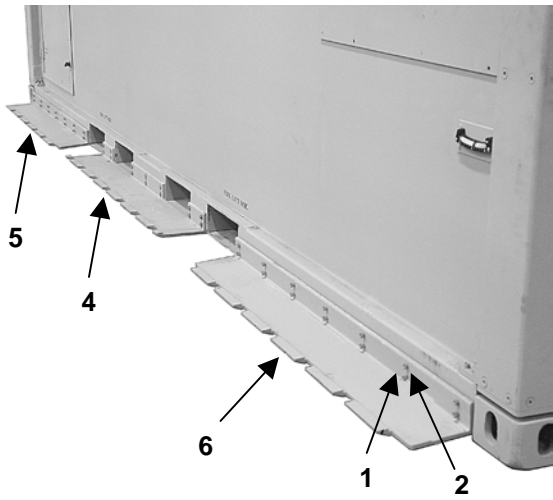

TM 9-4910-783-13&P

COMPONENTS OF END ITEM (COEI) LIST (cont'd)

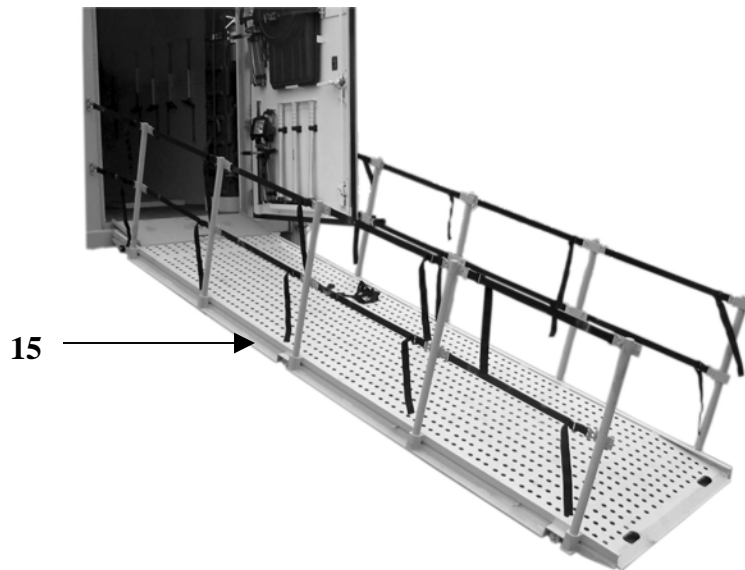
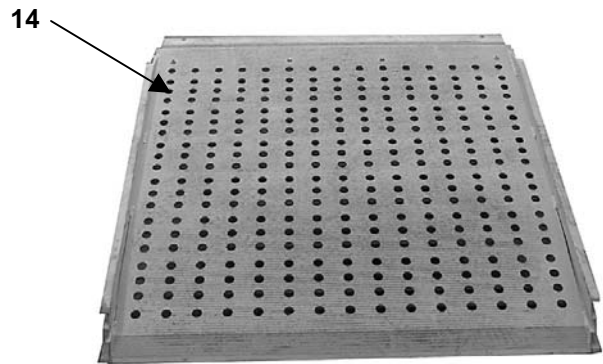
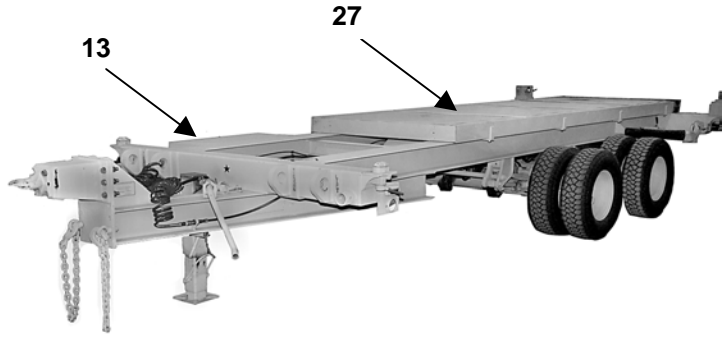

TM 9-4910-783-13&P

COMPONENTS OF END ITEM (COEI) AND BASIC ISSUE ITEMS (BII) LISTS

0056 00

COMPONENTS OF END ITEM (COEI) LIST (cont'd)

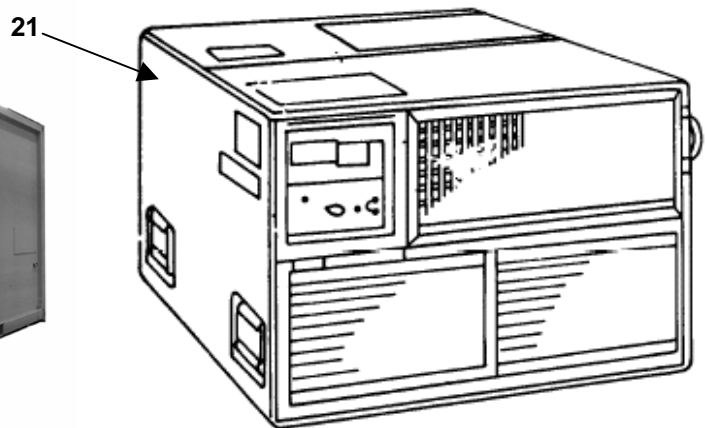
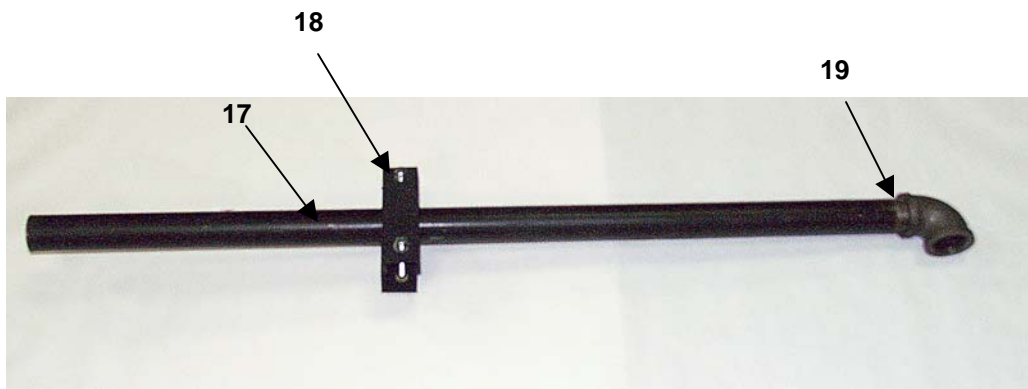
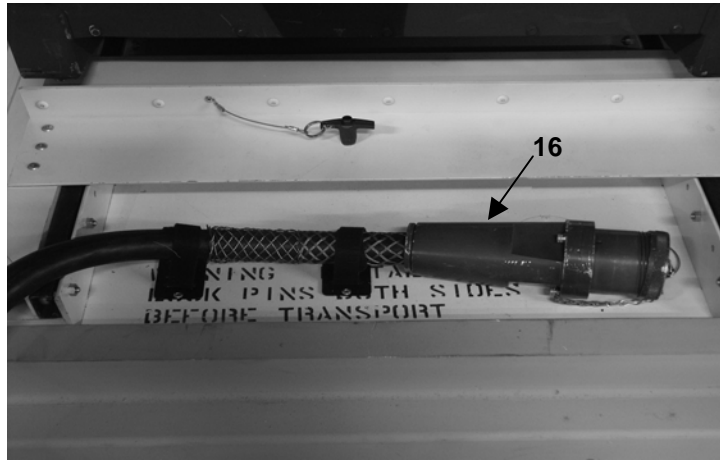

TM 9-4910-783-13&P

COMPONENTS OF END ITEM (COEI) LIST (cont'd)

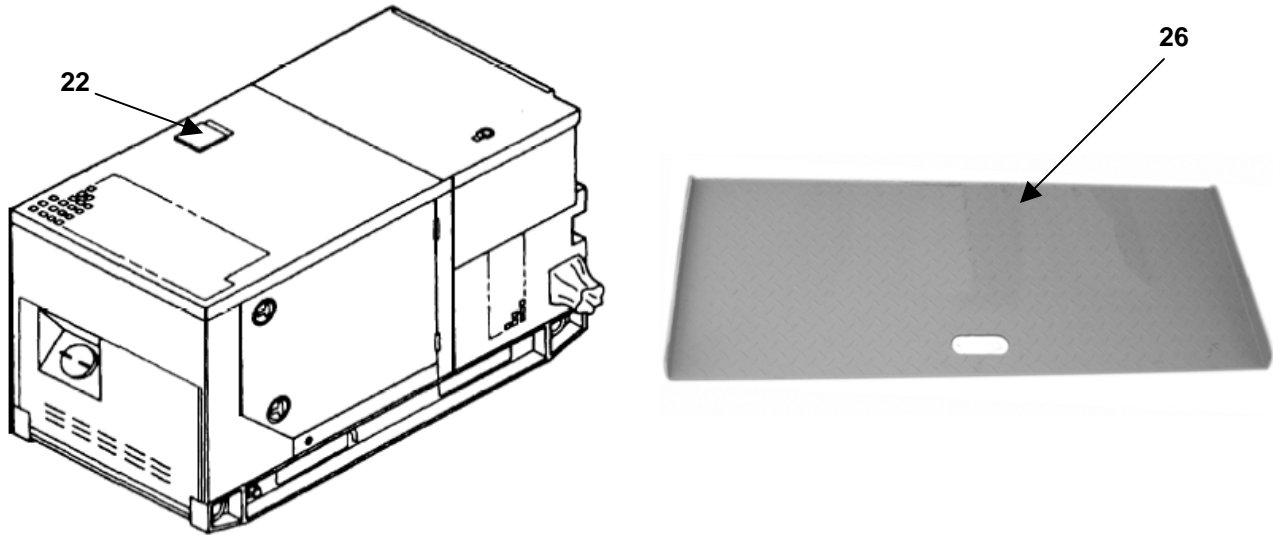
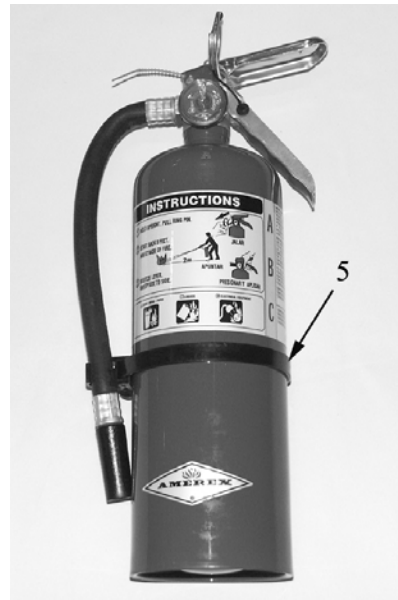
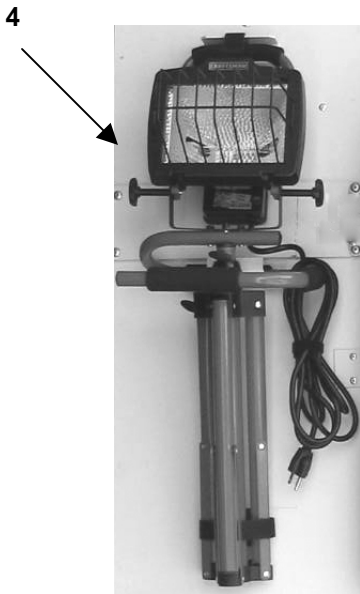
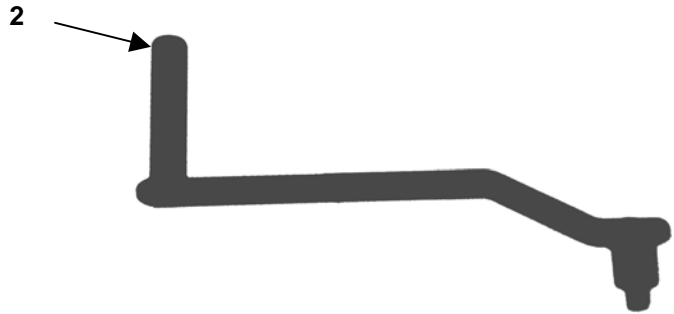

Table 1. Components of End Item List.

(1) Illustration Number	(2) National Stock Number	(3) Description CAGE and Part Number	(4) U/M	(5) QTY Req.
1		Detent Rail Bolt	ea	84
2		Detent Rail Washers	ea	84
3		Container, Rail Bolt/Washer	ea	1
4		Detent Rail Center (Wide)	ea	1
5		Detent Rail Front (Wide)	ea	1
6		Detent Rail Rear (Wide)	ea	1
7		Detent Rail Center (Thin)	ea	1
8		Detent Rail Front (Thin)	ea	1
9		Detent Rail Rear (Thin)	ea	1
10		T-PIN w/Lanyard	ea	4
11		Computer Cabinet	ea	1
12		Carbon Monoxide Detector	ea	1
13	2330-01-506-5979	20' Trailer	ea	1
14		Ramp, 4 FT	ea	1
15		Ramp, 14 FT	ea	1
16		Shore Power Cable Assembly	ea	1
17		37 ¼ inch Pipe	ea	1
18		Bracket Exhaust	ea	1
19		1 ¼ 90 Pipe Fitting	ea	1
20		20' ISO Container	ea	1
21	4120-01-193-4998	9K BTU ECU	ea	1
22	6115-01-274-7392	10kW Generator	ea	1
23	4910-01-490-6453	Base Tool Set (Black Drawers)	ea	1
24	4910-01-501-7342	Field Maintenance Module #1 (Green Drawers)	ea	1
25	4910-01-501-7343	Field Maintenance Module #2 (Tan Drawers)	ea	1
26		Threshold, Plate	ea	1
27		Ramp Storage Compartment	ea	1

TM 9-4910-783-13&P

BASIC ISSUE ITEMS (BII) LIST



TM 9-4910-783-13&P

BASIC ISSUE ITEMS (BII) LIST (cont)

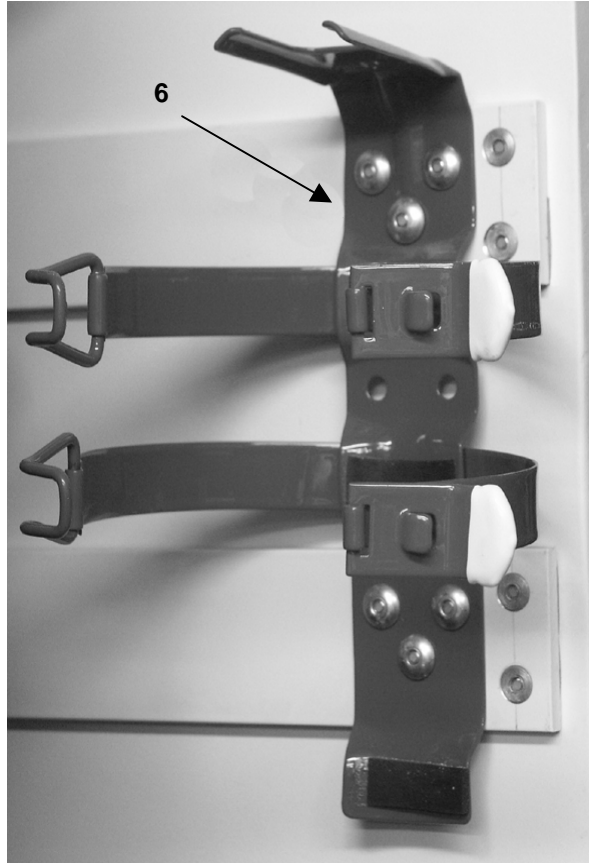

Table 2. Basic Issue Items List.

(1) Illustration Number	(2) National Stock Number	(3) Description CAGE and Part Number	(4) U/M	(5) QTY Req.
1		Work Bench	ea	2
2		Jack Handle Crank	ea	1
3		Slide Hammer	ea	1
4		External Area Lights	ea	2
5		Fire Extinguisher	ea	1
6		Mount	ea	1

END OF WORK PACKAGE

TM 9-4910-783-13&P

SCOPE

This section lists expendable and durable supplies you will need to operate and maintain the Standard Automotive Tool Set. These items are authorized to you by CTA 50-970, Expendable/Durable Items (Except Medical, Class V, Repair Parts, and Heraldic Items), or CTA 8-100, Army Medical Department Expendable/Durable Items.

EXPLANATION OF COLUMNS

a. Column (1) – Item Number. This number is assigned to the entry and is referenced in the narrative instructions to identify the material.

b. Column (2) – Level. This column identifies the lowest level of maintenance that requires the listed item.

C = OPERATOR/CREW
F = DIRECT SUPPORT

O = ORGANIZATIONAL
H = GENERAL SUPPORT

c. Column (3) – National Stock Number. This is the National stock number assigned to the item; use it to request or requisition the item.

d. Column (4) – Description. Indicates the Federal item name and, if required, a description to identify the item. The last line for each item indicates the Federal Supply Code for Manufacturer (FSCM) in parenthesis followed by the part number.

e. Column (5) – Unit of Measure (U/M). Indicates the measure used in performing the actual maintenance function. This measure is expressed by a two character alphabetical abbreviation (e.g., ea, in, pr). If the unit of measure differs from the unit of issue, requisition the lowest unit of issue that will satisfy your requirements.

TM 9-4910-783-13&P

EXPENDABLE AND DURABLE ITEMS LIST

0057 00

EXPENDABLE AND DURABLE ITEMS LIST

(1) ITEM NUMBER	(2) LEVEL	(3) NATIONAL STOCK NUMBER	(4) DESCRIPTION	(5) U / M
1	O	6810-00-995-4804	Activator (O-D-1271)	PT
2	O	9535-01-379-6098	Aluminum Alloy Sheet Stock (QQ-A-250/11)	SH
3	O	8010-01-160-6741	CARC Paint (MIL-C-46168)	KT
4	O	7930-00-531-9715	Detergent (MIL-D-16791)	GL
5	O	6810-00-995-4804	Diethylenetriamine Activator (DETA) (O-D-1271)	PT
6	O	6850-00-664-5685	Dry Cleaning Solvent (P-D-680B)	QT
7	O	8010-01-417-1215	Epoxy Primer (MIL-P-23377)	KT
8	O	8030-00-992-3156	Epoxy Resin (EA828 (12405))	GL
9	C, O	6810-00-577-4889	Isopropyl Alcohol (O-E-760)	QT
10	C, O	7920-00-044-9281	Low-lint Cleaning Cloth (MIL-C-85043)	BX
11	O	7920-00-205-1711	Rags	BE
12	C, O	8020-00-889-7917	Non-Metallic Brush (H-B-695)	EA
13	C	9540-01-372-1115	Patch Material, 6061T6, 0.050 inch	FT
14	C, O	8020-00-889-7917	Paint Brush	EA
15	C, O	9150-01-260-2534	Lubricant, Spray, MIL-L-23398	CN
16	O	8030-01-154-9250	Sealing Compound (MIL-S-8802)	KT
17	C, O	9150-01-197-7688	Grease, Automotive and Armament	OZ
	C, O	9150-01-197-7690	Grease, Automotive and Armament	LB
	C, O	9150-01-197-7681	Grease, Automotive and Armament	LB
18	C, O		Permabond 268	
19	O		Dowclene, EC (6K748)	
20	O		Devcon F	
21	O		EA9324 Adhesive (1JB33)	
22	O		PRC 1422 B-2 Sealant (7D294)	
23	O		Aluminum Power (MIL -A-82654)	

END OF WORK PACKAGE

TM 9-4910-783-13&P

APPENDIX A

BASE TOOLS

INVENTORY GUIDE

STANDARD AUTOMOTIVE TOOL SET (SATS)

TM 9-4910-783-13&P

SATS BASE TOOL COMPONENT LIST

0058 00

NOMENCLATURE	QTY	RACK	DRAWER	LOCATION
ACCESSORIES, DRILL AND SANDER	1	K	6	5 thru 9
ACCESSORIES, DRILL SHARPENER	1	K	4	3 thru 5
ADAPTER KIT, GREASE GUN COUPLING	1	H	4	4
ADAPTER, 3/4" DR TO 1/2" DR, 1/2"	1	J	5	8
ADAPTER, 3/8" DR MALE TO 1/2" DR FEMALE	1	J	3	88
ADAPTER, SOCKET WRENCH DRIVE, 1/2" MALE - 3/8" FEMALE	1	K	3	71
ADAPTER, SOCKET WRENCH DRIVE, 1/4" MALE - 3/8" FEMALE	1	K	3	70
ADAPTER, SOCKET WRENCH DRIVE, 3/4" MALE - 1/2" FEMALE	1	K	3	74
ADAPTER, SOCKET WRENCH DRIVE, 3/8" MALE - 1/2" FEMALE	1	K	3	75
ADAPTER, SOCKET WRENCH DRIVE, 3/8" MALE - 1/4" FEMALE	1	K	2	19
ADJUSTING TOOL, BRAKE SHOE	1	H	5	7
ANALYZER, BATTERY AND CHARGING SYSTEM	1	H	1	2
APRON, UTILITY	1	K	9	5
BALANCER, WHEEL	1	P		6
BAR, EXTENSION, IMPACT WRENCH, 3/8" DR, 2.5" LONG	1	J	3	91
BAR, EXTENSION, 1/2" DR, 2.5" LONG	1	J	3	80
BAR, EXTENSION, 1/2" DR, 4.5" LONG	1	J	3	83
BAR, EXTENSION, 1/2" DR, 9.5" LONG	1	J	3	85
BAR, EXTENSION, 3/4" DR, 6.5" LONG	1	J	2	19
BAR, EXTENSION, 3/4" DR, 12.5" LONG	1	J	2	14
BAR, EXTENSION, IMPACT WRENCH, 3/8" DR, 5.5" LONG	1	J	3	87
BAR, PINCH, 26"	2	L	2	2,5
BAR, PINCH, 36"	1	R		3
BAR, WRECKING	1	L	2	4
BATTERY FILLER, GRAVITY	1	H	1	7
BATTERY FILLER, SYRINGE	2	H	1	8, 9
BATTERY KIT, SERVICE	1	H	1	3
BEARING CUP PULLER ATTACHMENT	1	H	3	2
BEARING SPLITTER 15/16" MAX	1	H	3	5
BEARING SPLITTER, 2" MAX	1	H	3	6
BEARING SPLITTER, 4-5/8" MAX	1	H	3	3
BENDER SET, TUBE, HAND ACTUATED, 1/2" OD	1	L	4	6
BENDER SET, TUBE, HAND ACTUATED, 1/4" OD	1	L	4	10
BENDER SET, TUBE, HAND ACTUATED, 5/16" OD	1	L	4	9
BENDER SET, TUBE, HAND ACTUATED, 5/8" OD	1	L	4	5
BENDER SET, TUBE, HAND ACTUATED, 7/16" OD	1	L	4	7
BLADE, ABRASIVE, WHEEL	1	K	8	6
BLADE, HACKSAW, HAND	1	L	4	1

TM 9-4910-783-13&P

SATS BASE TOOL COMPONENT LIST

0058 00

NOMENCLATURE	QTY	RACK	DRAWER	LOCATION
BLOW GUN, AIR	2	K	9	3, 4
BOLTS	1	H	2	5
BOLTS FOR MECHANICAL PULLER SET	1	H	2	7
BOLTS FOR MECHANICAL PULLER SET	1	H	2	8
BOX, TOTE	5	P		7
BRAZING AND SOLDERING SET	1	H	4	3
BRUSH, FILE CLEANER	1	H	1	6
BRUSH, WIRE, ROTARY, END ATTACHMENT, CIRCULAR, SIDE FLARE	1	H	1	4
BRUSH, WIRE, ROTARY, END ATTACHMENT, SOLID WIRE FILLED	1	H	1	5
BRUSH, WIRE, SCRATCH	1	H	1	1
CABLE ASSEMBLY, BOOSTER	2	N		5
CABLE ASSEMBLY, POWER	2	G	1	1,2
CABLE ASSEMBLY, POWER	1	J	1	2
CABLE KIT, SPECIAL POWER	1	G	2	1
CAN, RADIATOR FILLING	2	Q		2
CAPS, VISE JAW	2	K	8	12, 13
CHARGER, BATTERY (NOTE: GFE ITEM)	1	P		1
CLAMP, C	2	L	5	2, 4
CLEANING COMPOUND (PROTOTYPE ITEM ONLY)	1	P		5
COMPRESSOR UNIT, RECIPROCATING	1	A		5
CREEPER, MECHANIC'S	5	Q		1
CRIMPING TOOL, TERMINAL	1	J	10	2
CROWBAR	1	M		2
CROWFOOT ATTACHMENT, FLARE NUT, 3/8" DR, 1/2"	1	J	4	55
CROWFOOT ATTACHMENT, FLARE NUT, 3/8" DR, 10MM	1	J	4	66
CROWFOOT ATTACHMENT, FLARE NUT, 3/8" DR, 11/16"	1	J	4	59
CROWFOOT ATTACHMENT, FLARE NUT, 3/8" DR, 11MM	1	J	4	67
CROWFOOT ATTACHMENT, FLARE NUT, 3/8" DR, 12MM	1	J	4	68
CROWFOOT ATTACHMENT, FLARE NUT, 3/8" DR, 13/16"	1	J	4	57
CROWFOOT ATTACHMENT, FLARE NUT, 3/8" DR, 13MM	1	J	4	69
CROWFOOT ATTACHMENT, FLARE NUT, 3/8" DR, 14MM	1	J	4	70
CROWFOOT ATTACHMENT, FLARE NUT, 3/8" DR, 15MM	1	J	4	71
CROWFOOT ATTACHMENT, FLARE NUT, 3/8" DR, 16MM	1	J	4	72
CROWFOOT ATTACHMENT, FLARE NUT, 3/8" DR, 17MM	1	J	4	73
CROWFOOT ATTACHMENT, FLARE NUT, 3/8" DR, 18MM	1	J	4	74
CROWFOOT ATTACHMENT, FLARE NUT, 3/8" DR, 3/4"	1	J	4	58
CROWFOOT ATTACHMENT, FLARE NUT, 3/8" DR, 5/8"	1	J	4	60
CROWFOOT ATTACHMENT, FLARE NUT, 3/8" DR, 9/16"	1	J	4	61

TM 9-4910-783-13&P

SATS BASE TOOL COMPONENT LIST

0058 00

NOMENCLATURE	QTY	RACK	DRAWER	LOCATION
CROWFOOT ATTACHMENT, FLARE NUT, 3/8" DR, 9MM	1	J	4	63
CROWFOOT ATTACHMENT, FLARE NUT, 3/8" DR, 3/8"	1	J	4	53
CROWFOOT ATTACHMENT, FLARE NUT, 3/8" DR, 7/16"	1	J	4	54
CUTTER, BOLT, LIGHTWEIGHT, 24"	1	L	5	3
CUTTER, BOLT, REPLACEMENT HEAD	1	L	5	1
CUTTING AND FLARING KIT, TUBE	1	L	4	2
DEGREASER, PORTABLE	1	B	2	3
DIE AND TAP SET, RETHREADING	1	J	7	1
DIE AND TAP SET, THREAD	1	J	7	2
DRESSER, ABRASIVE WHEEL	1	K	8	5
DRILL- DRIVER, ELECTRIC, 1/2"	1	K	6	4
DRILL SET, TWIST	1	K	5	3
DRILL SET, TWIST, LEFT HAND	1	K	5	4
DRILL, BATTERY, RECHARGEABLE, RIGHT ANGLE, 3/8"	1	K	4	1
DRILL, ELECTRIC, PORTABLE, RIGHT ANGLE, 1/2"	1	K	6	1
DRILL, ELECTRIC, PORTABLE, RIGHT ANGLE, 3/8"	1	K	6	2
DRILL, PNEUMATIC, RIGHT ANGLE	1	K	7	2
DRILL-DRIVER, BATTERY OPERATED, RECHARGEABLE, 18V 1/2"	1	K	5	6
EXTENSION ROD	1	H	2	3
EXTENSION ROD	1	H	2	4
EXTENSION, 1/2" DR, 10" LONG	1	K	2	69
EXTENSION, 1/2" DR, 2" LONG	1	K	3	76
EXTENSION, 1/2" DR, 3" LONG	1	K	2	97
EXTENSION, 1/2" DR, 5" LONG	1	K	2	96
EXTENSION, 1/4" DR, 2.5" LONG	1	K	2	18
EXTENSION, 1/4" DR, 5.5" LONG	1	K	2	16
EXTENSION, 1/4" DR, 9.5" LONG	1	K	2	17
EXTENSION, 3/4" DR, 15" LONG	1	J	5	1
EXTENSION, 3/4" DR, 4.5" LONG	1	J	5	3
EXTENSION, 3/4" DR, 7.5" LONG	1	J	5	2
EXTENSION, 3/8" DR, 2" LONG	1	K	3	72
EXTENSION, 3/8" DR, 3" LONG	1	K	3	1
EXTENSION, 3/8" DR, 6" LONG	1	K	3	2
EXTENSION, 3/8" DR, 9.5" LONG	1	K	3	3
EXTINGUISHER, FIRE, 5 LB CAPACITY (PROTOTYPE)	2	M		3
EXTRACTOR SET, HARDENED SCREW	2	K	5	1, 2
EXTRACTOR SET, SCREW	1	K	5	5
FACE SHIELD, INDUSTRIAL	1	K	9	1

TM 9-4910-783-13&P

SATS BASE TOOL COMPONENT LIST

0058 00

NOMENCLATURE	QTY	RACK	DRAWER	LOCATION
FEMALE THREADED ADAPTER, 1-1/4"	1	H	2	17
FEMALE THREADED ADAPTER, 1-1/8"	1	H	2	21
FEMALE THREADED ADAPTER, 1/2"	1	H	2	14
FEMALE THREADED ADAPTER, 2"	1	H	2	15
FEMALE THREADED ADAPTER, 3/4"	1	H	2	27
FEMALE THREADED ADAPTER, 5/8"	1	H	2	23
FEMALE THREADED ADAPTER, 5/8"	1	H	2	28
FEMALE THREADED ADAPTER, 7/8"	1	H	2	25
FILE SET, HAND, 1/2" RD AMER BAS, 12"	1	L	1	3
FILE SET, HAND, 1/2" RD AMER BAS, 12"	1	L	1	4
FILE SET, HAND, HALF RD, AMER, BAS, 12"	1	L	1	1
FILE SET, HAND, HALF RD, AMER, BAS, 12"	1	L	1	2
FILE THREAD RESTORER KIT	1	L	1	27
FILLER AND BLEEDER KIT, BRAKE SYSTEM	1	H	5	10
FILTER, SOLVENT, FOR WASHER (PROTOTYPE)	1	B	2	2
FINGER, MECHANICAL	1	L	2	3
FLANGE-TYPE PULLER	1	H	2	1
FOUNTAIN, EYE AND FACE	1	N		2
FOUR FOOT RAMP	1	A		2
FUNNEL	1	P		2
FUNNEL, FLEXIBLE SPOUT	1	P		2
GAGE, WHEEL ALIGNMENT (NOTE: GFE)	1	P		3
GEAR AND PULLEY PULLERS, 13"	1	H	2	29
GLOVES, RUBBER, INDUSTRIAL	1	K	9	7
GOGGLES, INDUSTRIAL	1	K	9	2
GREASE GUN KIT	1	P		3
GREASE GUN, PNEUMATIC	1	H	6	3
GREASE GUN, PNEUMATIC, HOSE	1	H	6	2
GRINDING MACHINE, UTILITY	1	B	3	2
GUN, FLUID, DIRECT DELIVERY	2	H	6	1, 4
HAMMER, HAND, CARPENTER'S, CURVED CLAW, 16 OZ	2	L	3	3, 9
HAMMER, HAND, DEAD BLOW, BALL PEEN, 40 OZ	2	L	3	7, 8
HAMMER, HAND, SOFT FACE, DEAD BLOW, 10 OZ	2	L	3	1, 6
HAMMER, HAND, SOFT FACE, DEAD BLOW, 52 OZ	2	L	3	4, 5
HAMMER, HAND, SOFT FACE, DEAD BLOW, 1-1/2"	1	L	3	10
HAMMER, PNEUMATIC	1	K	7	3
HAMMER, SLEDGE, DOUBLE FACED, 10 LB	2	R		2
HAMMER, SOFT FACE, 1.5", WITH TIPS, HARD, MEDIUM	1	L	3	2

TM 9-4910-783-13&P

SATS BASE TOOL COMPONENT LIST

0058 00

NOMENCLATURE	QTY	RACK	DRAWER	LOCATION
HAMMER, SOFT FACE, 2", WITH TIPS, TOUGH, EXTRA TOUGH	1	L	3	2
HANDLE, RATCHET, 1/2" DR, 10" LONG	1	K	3	5
HANDLE, RATCHET, 3/4" DR, 17" LONG	1	J	5	11
HANDLE, RATCHET, 3/8" DR, 6" LONG	1	K	3	4
HANDLE, REVERSIBLE RATCHET, SOCKET WRENCH, 1/4" DR, 4.375" LONG	1	K	2	15
HANDLE, SLIDING-T, 3/4" DR, 17" LONG	1	J	5	10
HOSE ASSEMBLY, AIR, NONMETALLIC	2	A		5
INFLATOR-GAGE AND HOSE ASSEMBLY, PNEUMATIC TIRE	1	K	9	6
JACK, BOTTLE, HYDRAULIC, HAND, 12 TON	1	B	3	1
2-JAW PULLER, 13 TON, 11"	1	H	3	4
2-JAW PULLER, 2 TON, 3-1/4"	1	H	3	7
2-JAW PULLER, 5 TON, 3-1/4"	1	H	3	9
2-JAW PULLER, 7 TON, 5"	1	H	3	8
JOINT, UNIVERSAL, 1/2" DR	1	J	3	84
JOINT, UNIVERSAL, 1/2" DR	1	K	3	77
JOINT, UNIVERSAL, 1/4" DR	1	K	2	20
JOINT, UNIVERSAL, 3/4" DR	1	J	5	9
JOINT, UNIVERSAL, 3/8" DR	1	J	3	89
JOINT, UNIVERSAL, 3/8" DR	1	K	3	73
KEY SET, HEX, METRIC	1	J	4	64
KEY SET, HEX, STANDARD	1	J	4	65
LAMP, FLUORESCENT (REPLACEMENT BULK) (PROTOTYPE)	1	H	10	5
LIGHT, BATTERY 18V, RECHARGEABLE, CASE	1	H	10	1
LIGHT, EXTENSION	1	H	10	2
LIGHT, EXTENSION, LED (PROTOTYPE)	2	H	10	3,4
LUBRICATING GUN, BATTERY, RECHARGEABLE, 12V	1	H	8	1
LUBRICATING GUN, HAND	3	H	7	2,3,4
MEASURE, LIQUID, 2 QUART	1	P		2
MEASURE, LIQUID, 8 QUART	1	P		2
MULTIMETER	2	J	10	1,4
MULTIPLIER, TORQUE	1	K	1	1
MULTIPLIER, TORQUE, BAR	1	K	1	3
OILER, HAND	2	H	7	1,5
PAN, DRAIN	1	R		1
PILOT BEARING PULLER	1	H	2	2
PLATE, BOLSTER, 12 TON JACK, 24" X 24"	2	N		3
PLATE, BOLSTER, 1 TON JACK, TRANSMISSION, 48" X 72"	2	N		5
PLIERS SET, RETAINING RING	1	J	8	2

TM 9-4910-783-13&P

SATS BASE TOOL COMPONENT LIST

0058 00

NOMENCLATURE	QTY	RACK	DRAWER	LOCATION
PLIERS, BRAKE REPAIR, HEAVY	1	H	5	5
PLIERS, BRAKE REPAIR, LIGHT	1	H	5	6
PLIERS, LOCK RING	1	J	8	1
PLIERS, LOCK RING	1	J	8	3
PLIERS, WIRE TWISTER	1	J	10	5
PNEUMATIC BAG KIT, LIFTING	1	D		8
PULLER SET, MECHANICAL	1	H	2	1 thru 29
PULLER SET, MECHANICAL	1	H	3	1 thru 9
PULLER, MECHANICAL, PITTMAN ARM	1	H	4	1
PULLER, MECHANICAL, STEERING WHEEL	1	H	4	2
PULLER, PITTMAN ARM	1	H	3	1
PUMP, LUBRICANT	1	B	1	2
PUNCH AND CHISEL SET, CHISEL, 1" DIA, 1-3/16"	1	L	1	16
PUNCH AND CHISEL SET, CHISEL, 1/2" DIA, 5/8"	1	L	1	12
PUNCH AND CHISEL SET, CHISEL, 1/4" DIA, 5/16"	1	L	1	9
PUNCH AND CHISEL SET, CHISEL, 3/16" DIA, 1/4"	1	L	1	8
PUNCH AND CHISEL SET, CHISEL, 3/4" DIA, 7/8"	1	L	1	14
PUNCH AND CHISEL SET, CHISEL, 5/16" DIA, 3/8"	1	L	1	10
PUNCH AND CHISEL SET, CHISEL, 5/8" DIA, 3/4"	1	L	1	13
PUNCH AND CHISEL SET, CHISEL, 7/16" DIA, 1/2"	1	L	1	11
PUNCH AND CHISEL SET, CHISEL, 7/8" DIA, 1"	1	L	1	15
PUNCH AND CHISEL SET, PUNCH, 1/2"	1	L	1	23
PUNCH AND CHISEL SET, PUNCH, 1/2", 1/4" PT	1	L	1	17
PUNCH AND CHISEL SET, PUNCH, 1/4", 3/32" PT	1	L	1	22
PUNCH AND CHISEL SET, PUNCH, 3/8"	1	L	1	24
PUNCH AND CHISEL SET, PUNCH, 3/8", 3/16" PT	1	L	1	19
PUNCH AND CHISEL SET, PUNCH, 5/16"	1	L	1	25
PUNCH AND CHISEL SET, PUNCH, 5/16", 1/8" PT	1	L	1	21
PUNCH AND CHISEL SET, PUNCH, 5/16", 5/32" PT	1	L	1	20
PUNCH AND CHISEL SET, PUNCH, 7/16", 7/32" PT	1	L	1	18
PUNCH AND CHISEL SET, PUNCH, 1/2" DIA, 1/4" PT	1	L	1	5
PUNCH AND CHISEL SET, PUNCH, 1/2" DIA, 1/4" PT	1	L	1	28
PUNCH AND CHISEL SET, PUNCH, 1/4" DIA, 3/32" PT	1	L	1	32
PUNCH AND CHISEL SET, PUNCH, 3/8" DIA, 3/16" PT	1	L	1	6
PUNCH AND CHISEL SET, PUNCH, 3/8" DIA, 3/16" PT	1	L	1	30
PUNCH AND CHISEL SET, PUNCH, 5/16" DIA, 1/8" PT	1	L	1	7
PUNCH AND CHISEL SET, PUNCH, 5/16" DIA, 1/8" PT	1	L	1	31
PUNCH AND CHISEL SET, PUNCH, 7/16" DIA, 7/32" PT	1	L	1	29

TM 9-4910-783-13&P

SATS BASE TOOL COMPONENT LIST

0058 00

NOMENCLATURE	QTY	RACK	DRAWER	LOCATION
PUNCH SET, CUTTING, DOUBLE BOW, GASKET	1	K	8	2
PUNCH, CHISEL, HOLDER	1	L	1	26
PUSH PULLER W/ 6-3/4" LEGS	1	H	2	18
SANDER/GRINDER, 4-1/2"	1	K	6	3
SAW, HAND, CROSSCUT	1	L	2	6
SAW, HAND, METAL CUTTING	1	L	4	11
SAW, HAND, METAL CUTTING	1	L	4	12
SAW, HAND, METAL CUTTING, CLOSE QUARTERS	1	L	4	3
SAW, HAND, METAL CUTTING, CLOSE QUARTERS	1	L	4	4
SCALE, WEIGHING	1	L	2	1
SCRAPER, GASKET	2	K	8	3,11
SCREWDRIVER ATTACHMENT HEX, 1/2" DR, 1/2"	1	J	4	33
SCREWDRIVER ATTACHMENT HEX, 1/2" DR, 12MM	1	J	4	50
SCREWDRIVER ATTACHMENT HEX, 1/2" DR, 14MM	1	J	4	51
SCREWDRIVER ATTACHMENT HEX, 1/2" DR, 17MM	1	J	4	52
SCREWDRIVER ATTACHMENT HEX, 1/2" DR, 5/8"	1	J	4	31
SCREWDRIVER ATTACHMENT HEX, 1/2" DR, 9/16"	1	J	4	32
SCREWDRIVER ATTACHMENT HEX, 3/8" DR, 1/4"	1	J	4	36
SCREWDRIVER ATTACHMENT HEX, 3/8" DR, 1/8"	1	J	4	40
SCREWDRIVER ATTACHMENT HEX, 3/8" DR, 10MM	1	J	4	49
SCREWDRIVER ATTACHMENT HEX, 3/8" DR, 3/16"	1	J	4	38
SCREWDRIVER ATTACHMENT HEX, 3/8" DR, 3/8"	1	J	4	34
SCREWDRIVER ATTACHMENT HEX, 3/8" DR, 4MM	1	J	4	43
SCREWDRIVER ATTACHMENT HEX, 3/8" DR, 5/16"	1	J	4	35
SCREWDRIVER ATTACHMENT HEX, 3/8" DR, 5/32"	1	J	4	39
SCREWDRIVER ATTACHMENT HEX, 3/8" DR, 5MM	1	J	4	44
SCREWDRIVER ATTACHMENT HEX, 3/8" DR, 6MM	1	J	4	45
SCREWDRIVER ATTACHMENT HEX, 3/8" DR, 7/32"	1	J	4	37
SCREWDRIVER ATTACHMENT HEX, 3/8" DR, 7MM	1	J	4	46
SCREWDRIVER ATTACHMENT HEX, 3/8" DR, 8MM	1	J	4	47
SCREWDRIVER ATTACHMENT HEX, 3/8" DR, 9MM	1	J	4	48
SCREWDRIVER ATTACHMENT, TORX BIT, 1/4" DR, T-8	1	J	4	17
SCREWDRIVER ATTACHMENT, TORX BIT, 1/4" DR, T-10	1	J	4	18
SCREWDRIVER ATTACHMENT, TORX BIT, 1/4" DR, T-15	1	J	4	19
SCREWDRIVER ATTACHMENT, TORX BIT, 1/4" DR, T-20	1	J	4	20
SCREWDRIVER ATTACHMENT, TORX BIT, 1/4" DR, T-25	1	J	4	21
SCREWDRIVER ATTACHMENT, TORX BIT, 1/4" DR, T-27	1	J	4	22
SCREWDRIVER ATTACHMENT, TORX BIT, 3/8" DR, T-40	1	J	4	24

TM 9-4910-783-13&P

SATS BASE TOOL COMPONENT LIST

0058 00

NOMENCLATURE	QTY	RACK	DRAWER	LOCATION
SCREWDRIVER ATTACHMENT, TORX BIT, 3/8" DR, T-45	1	J	4	25
SCREWDRIVER ATTACHMENT, TORX BIT, 3/8" DR, T-47	1	J	4	26
SCREWDRIVER ATTACHMENT, TORX BIT, 3/8" DR, T-50	1	J	4	27
SCREWDRIVER ATTACHMENT, TORX BIT, 3/8" DR, T-55	1	J	4	28
SCREWDRIVER ATTACHMENT, TORX BIT, T-30	1	J	4	23
SCREWDRIVER, JEWELER, #0	1	H	9	19
SCREWDRIVER, JEWELER, #00	1	H	9	18
SCREWDRIVER, JEWELER, #1	1	H	9	20
SCREWDRIVER, JEWELER, 1.5MM	1	H	9	14
SCREWDRIVER, JEWELER, 2.5MM	1	H	9	16
SCREWDRIVER, JEWELER, 2MM	1	H	9	15
SCREWDRIVER, JEWELER, 3MM	1	H	9	17
SCREWDRIVER, OFFSET, CROSS TIP, #1 & #2 TIP, 4.5" LONG	1	H	9	9
SCREWDRIVER, OFFSET, CROSS TIP, #3 & #4 TIP, 6.5" LONG	1	H	9	7
SCREWDRIVER, OFFSET, FLAT TIP, 1/4" TIP, 4" LONG	1	H	9	4
SCREWDRIVER, OFFSET, FLAT TIP, 3/8" TIP, 6" LONG	1	H	9	2
SCREWDRIVER, OFFSET, FLAT TIP, 5/16" TIP, 5" LONG	1	H	9	3
SCREWDRIVER, OFFSET, FLAT TIP, 5/32" TIP, 3" LONG	1	H	9	1
SCREWDRIVER, ROUND SHANK, CROSS TIP, #4 TIP, 13.5" LONG	1	H	9	8
SCREWDRIVER, ROUND SHANK, CROSS TIP, #4 TIP, 13.5" LONG	1	H	9	10
SCREWDRIVER, SQUARE SHANK, FLAT TIP, 3/8" TIP, 17.5" LONG	1	H	9	12
SCREWDRIVER, SQUARE SHANK, FLAT TIP, 3/8" TIP, 17.5" LONG	1	H	9	13
SCREWDRIVER, STUBBY, CROSS TIP, #2, 3.5" LONG	1	H	9	5
SCREWDRIVER, STUBBY, FLAT TIP, 1/4" TIP, 3.5" LONG	1	H	9	6
SCREWDRIVER, STUBBY, FLAT TIP, 3/16" TIP, 3" LONG	1	H	9	11
SCREWDRIVER, TORX, T10, 3" LONG	1	H	9	21
SCREWDRIVER, TORX, T15, 1.25" LONG	1	H	9	23
SCREWDRIVER, TORX, T15, 3" LONG	1	H	9	22
SCREWDRIVER, TORX, T20, 3" LONG	1	H	9	24
SCREWDRIVER, TORX, T25, 3" LONG	1	H	9	25
SCREWDRIVER, TORX, T27, 4" LONG	1	H	9	26
SCREWDRIVER, TORX, T30, 4" LONG	1	H	9	27
SCREWDRIVER, TORX, T40, 6" LONG	1	H	9	28
SHARPENER, DRILL, PORTABLE	1	K	4	2
SHEARS, BENT, TRIMMER	1	K	8	4
SLIDE HAMMER PULLER	1	H	2	6
SOCKET, DOUBLE-END IMPACT, 3/4" X 13/16"	1	J	3	24
SOCKET, IMPACT SOCKET, 3/4" DR REGULAR, 6 PT, 1-11/16"	1	J	2	33

TM 9-4910-783-13&P

SATS BASE TOOL COMPONENT LIST

0058 00

NOMENCLATURE	QTY	RACK	DRAWER	LOCATION
SOCKET, IMPACT SOCKET, 3/4" DR REGULAR, 6 PT, 1-13/16"	1	J	2	40
SOCKET, IMPACT SOCKET, 3/4" DR REGULAR, 6 PT, 1-15/16"	1	J	2	57
SOCKET, IMPACT SOCKET, 3/4" DR REGULAR, 6 PT, 1-3/4"	1	J	2	39
SOCKET, IMPACT SOCKET, 3/4" DR REGULAR, 6 PT, 1-5/8"	1	J	2	34
SOCKET, IMPACT SOCKET, 3/4" DR REGULAR, 6 PT, 1-7/8"	1	J	2	56
SOCKET, IMPACT SOCKET, 3/4" DR REGULAR, 6 PT, 1-9/16"	1	J	2	28
SOCKET, IMPACT SOCKET, 3/4" DR REGULAR, 6 PT, 2"	1	J	2	41
SOCKET, IMPACT SOCKET, 3/4" DR, 4 PT, DEEP, BUDD WHEEL, DOUBLE OPENING, 1-1/2" 6 PT & 13/16"	1	J	2	24
SOCKET, IMPACT SOCKET, 3/4" DR, 6 PT, 17MM	1	J	2	18
SOCKET, IMPACT SOCKET, 3/4" DR, 6 PT, 19MM	1	J	2	17
SOCKET, IMPACT SOCKET, 3/4" DR, 6 PT, 20MM	1	J	2	16
SOCKET, IMPACT SOCKET, 3/4" DR, 6 PT, 22MM	1	J	2	15
SOCKET, IMPACT SOCKET, 3/4" DR, 6 PT, 24MM	1	J	2	22
SOCKET, IMPACT SOCKET, 3/4" DR, 6 PT, 27MM	1	J	2	21
SOCKET, IMPACT SOCKET, 3/4" DR, 6 PT, 30MM	1	J	2	20
SOCKET, IMPACT SOCKET, 3/4" DR, 6 PT, 31MM	1	J	2	25
SOCKET, IMPACT SOCKET, 3/4" DR, 6 PT, 34MM	1	J	2	26
SOCKET, IMPACT SOCKET, 3/4" DR, 6 PT, 36MM	1	J	2	27
SOCKET, IMPACT SOCKET, 3/4" DR, 6 PT, 38MM	1	J	2	32
SOCKET, IMPACT SOCKET, 3/4" DR, 6 PT, 40MM	1	J	2	31
SOCKET, IMPACT SOCKET, 3/4" DR, 6 PT, 46MM	1	J	2	30
SOCKET, IMPACT SOCKET, 3/4" DR, DEEP, 4 PT, 13/16"	1	J	2	23
SOCKET, IMPACT SOCKET, UNIVERSAL, 1/2" DR, 6 PT, 13MM	1	J	2	50
SOCKET, IMPACT SOCKET, UNIVERSAL, 1/2" DR, 6 PT, 14MM	1	J	2	49
SOCKET, IMPACT SOCKET, UNIVERSAL, 1/2" DR, 6 PT, 1/2"	1	J	2	38
SOCKET, IMPACT SOCKET, UNIVERSAL, 1/2" DR, 6 PT, 11/16"	1	J	2	35
SOCKET, IMPACT SOCKET, UNIVERSAL, 1/2" DR, 6 PT, 13/16"	1	J	2	43
SOCKET, IMPACT SOCKET, UNIVERSAL, 1/2" DR, 6 PT, 15/16"	1	J	2	45
SOCKET, IMPACT SOCKET, UNIVERSAL, 1/2" DR, 6 PT, 15MM	1	J	2	48
SOCKET, IMPACT SOCKET, UNIVERSAL, 1/2" DR, 6 PT, 16MM	1	J	2	47
SOCKET, IMPACT SOCKET, UNIVERSAL, 1/2" DR, 6 PT, 17MM	1	J	2	46
SOCKET, IMPACT SOCKET, UNIVERSAL, 1/2" DR, 6 PT, 18MM	1	J	2	51
SOCKET, IMPACT SOCKET, UNIVERSAL, 1/2" DR, 6 PT, 21MM	1	J	2	53
SOCKET, IMPACT SOCKET, UNIVERSAL, 1/2" DR, 6 PT, 22MM	1	J	2	54
SOCKET, IMPACT SOCKET, UNIVERSAL, 1/2" DR, 6 PT, 24MM	1	J	2	55
SOCKET, IMPACT SOCKET, UNIVERSAL, 1/2" DR, 6 PT, 3/4"	1	J	2	42
SOCKET, IMPACT SOCKET, UNIVERSAL, 1/2" DR, 6 PT, 5/8"	1	J	2	36
SOCKET, IMPACT SOCKET, UNIVERSAL, 1/2" DR, 6 PT, 7/8"	1	J	2	44

TM 9-4910-783-13&P

SATS BASE TOOL COMPONENT LIST

0058 00

NOMENCLATURE	QTY	RACK	DRAWER	LOCATION
SOCKET, IMPACT SOCKET, UNIVERSAL, 1/2" DR, 6 PT, 9/16"	1	J	2	37
SOCKET, IMPACT SOCKET, UNIVERSAL, 1/2" DR, 6 PT, 19MM	1	J	2	52
SOCKET, IMPACT WRENCH, 1/2" DR, 6 PT, 1-1/16"	1	J	3	75
SOCKET, IMPACT WRENCH, 1/2" DR, 6 PT, 1"	1	J	3	76
SOCKET, IMPACT WRENCH, 1/2" DR, 6 PT, 1/2"	1	J	3	71
SOCKET, IMPACT WRENCH, 1/2" DR, 6 PT, 11/16"	1	J	3	65
SOCKET, IMPACT WRENCH, 1/2" DR, 6 PT, 12MM	1	J	3	52
SOCKET, IMPACT WRENCH, 1/2" DR, 6 PT, 13/16"	1	J	3	79
SOCKET, IMPACT WRENCH, 1/2" DR, 6 PT, 13MM	1	J	3	63
SOCKET, IMPACT WRENCH, 1/2" DR, 6 PT, 14MM	1	J	3	68
SOCKET, IMPACT WRENCH, 1/2" DR, 6 PT, 15/16"	1	J	3	77
SOCKET, IMPACT WRENCH, 1/2" DR, 6 PT, 15MM	1	J	3	74
SOCKET, IMPACT WRENCH, 1/2" DR, 6 PT, 16MM	1	J	3	81
SOCKET, IMPACT WRENCH, 1/2" DR, 6 PT, 17MM	1	J	3	86
SOCKET, IMPACT WRENCH, 1/2" DR, 6 PT, 18MM	1	J	3	90
SOCKET, IMPACT WRENCH, 1/2" DR, 6 PT, 19MM	1	J	3	93
SOCKET, IMPACT WRENCH, 1/2" DR, 6 PT, 21MM	1	J	3	94
SOCKET, IMPACT WRENCH, 1/2" DR, 6 PT, 22MM	1	J	3	95
SOCKET, IMPACT WRENCH, 1/2" DR, 6 PT, 24MM	1	J	3	96
SOCKET, IMPACT WRENCH, 1/2" DR, 6 PT, 27MM	1	J	3	97
SOCKET, IMPACT WRENCH, 1/2" DR, 6 PT, 3/4"	1	J	3	73
SOCKET, IMPACT WRENCH, 1/2" DR, 6 PT, 3/8"	1	J	3	69
SOCKET, IMPACT WRENCH, 1/2" DR, 6 PT, 5/8"	1	J	3	64
SOCKET, IMPACT WRENCH, 1/2" DR, 6 PT, 7/16"	1	J	3	70
SOCKET, IMPACT WRENCH, 1/2" DR, 6 PT, 7/8"	1	J	3	78
SOCKET, IMPACT WRENCH, 1/2" DR, 6 PT, 9/16"	1	J	3	72
SOCKET, IMPACT WRENCH, 1/2" DR, 6 PT, DEEP, 1"	1	J	3	14
SOCKET, IMPACT WRENCH, 1/2" DR, 6 PT, DEEP, 1/2"	1	J	3	22
SOCKET, IMPACT WRENCH, 1/2" DR, 6 PT, DEEP, 11/16"	1	J	3	19
SOCKET, IMPACT WRENCH, 1/2" DR, 6 PT, DEEP, 1-1/16"	1	J	3	13
SOCKET, IMPACT WRENCH, 1/2" DR, 6 PT, DEEP, 12MM	1	J	3	1
SOCKET, IMPACT WRENCH, 1/2" DR, 6 PT, DEEP, 13/16"	1	J	3	17
SOCKET, IMPACT WRENCH, 1/2" DR, 6 PT, DEEP, 13MM	1	J	3	2
SOCKET, IMPACT WRENCH, 1/2" DR, 6 PT, DEEP, 14MM	1	J	3	3
SOCKET, IMPACT WRENCH, 1/2" DR, 6 PT, DEEP, 15/16"	1	J	3	15
SOCKET, IMPACT WRENCH, 1/2" DR, 6 PT, DEEP, 15MM	1	J	3	4
SOCKET, IMPACT WRENCH, 1/2" DR, 6 PT, DEEP, 16MM	1	J	3	5
SOCKET, IMPACT WRENCH, 1/2" DR, 6 PT, DEEP, 17MM	1	J	3	6

TM 9-4910-783-13&P

SATS BASE TOOL COMPONENT LIST

0058 00

NOMENCLATURE	QTY	RACK	DRAWER	LOCATION
SOCKET, IMPACT WRENCH, 1/2" DR, 6 PT, DEEP, 18MM	1	J	3	7
SOCKET, IMPACT WRENCH, 1/2" DR, 6 PT, DEEP, 19MM	1	J	3	8
SOCKET, IMPACT WRENCH, 1/2" DR, 6 PT, DEEP, 21MM	1	J	3	9
SOCKET, IMPACT WRENCH, 1/2" DR, 6 PT, DEEP, 22MM	1	J	3	10
SOCKET, IMPACT WRENCH, 1/2" DR, 6 PT, DEEP, 24MM	1	J	3	11
SOCKET, IMPACT WRENCH, 1/2" DR, 6 PT, DEEP, 27MM	1	J	3	12
SOCKET, IMPACT WRENCH, 1/2" DR, 6 PT, DEEP, 3/4"	1	J	3	18
SOCKET, IMPACT WRENCH, 1/2" DR, 6 PT, DEEP, 3/8"	1	J	3	38
SOCKET, IMPACT WRENCH, 1/2" DR, 6 PT, DEEP, 5/8"	1	J	3	20
SOCKET, IMPACT WRENCH, 1/2" DR, 6 PT, DEEP, 7/16"	1	J	3	23
SOCKET, IMPACT WRENCH, 1/2" DR, 6 PT, DEEP, 7/8"	1	J	3	16
SOCKET, IMPACT WRENCH, 1/2" DR, 6 PT, DEEP, 9/16"	1	J	3	21
SOCKET, IMPACT WRENCH, 3/4" DR, 6 PT, 1"	1	J	2	13
SOCKET, IMPACT WRENCH, 3/4" DR, 6 PT, 11/16"	1	J	2	9
SOCKET, IMPACT WRENCH, 3/4" DR, 6 PT, 1-1/16"	1	J	2	6
SOCKET, IMPACT WRENCH, 3/4" DR, 6 PT, 1-1/2"	1	J	2	1
SOCKET, IMPACT WRENCH, 3/4" DR, 6 PT, 1-1/2"	1	J	2	29
SOCKET, IMPACT WRENCH, 3/4" DR, 6 PT, 1-1/4"	1	J	2	4
SOCKET, IMPACT WRENCH, 3/4" DR, 6 PT, 1-1/8"	1	J	2	5
SOCKET, IMPACT WRENCH, 3/4" DR, 6 PT, 13/16"	1	J	2	11
SOCKET, IMPACT WRENCH, 3/4" DR, 6 PT, 1-5/16"	1	J	2	3
SOCKET, IMPACT WRENCH, 3/4" DR, 6 PT, 1-7/16"	1	J	2	2
SOCKET, IMPACT WRENCH, 3/4" DR, 6 PT, 3/4"	1	J	2	10
SOCKET, IMPACT WRENCH, 3/4" DR, 6 PT, 5/8"	1	J	2	8
SOCKET, IMPACT WRENCH, 3/4" DR, 6 PT, 7/8"	1	J	2	12
SOCKET, IMPACT WRENCH, 3/4" DR, 6 PT, 9/16"	1	J	2	7
SOCKET, IMPACT WRENCH, 3/8" DR, 6 PT, 1/2"	1	J	3	50
SOCKET, IMPACT WRENCH, 3/8" DR, 6 PT, 1/4"	1	J	3	66
SOCKET, IMPACT WRENCH, 3/8" DR, 6 PT, 10MM	1	J	3	28
SOCKET, IMPACT WRENCH, 3/8" DR, 6 PT, 11/16"	1	J	3	47
SOCKET, IMPACT WRENCH, 3/8" DR, 6 PT, 11MM	1	J	3	29
SOCKET, IMPACT WRENCH, 3/8" DR, 6 PT, 12MM	1	J	3	30
SOCKET, IMPACT WRENCH, 3/8" DR, 6 PT, 13MM	1	J	3	31
SOCKET, IMPACT WRENCH, 3/8" DR, 6 PT, 14MM	1	J	3	32
SOCKET, IMPACT WRENCH, 3/8" DR, 6 PT, 15MM	1	J	3	33
SOCKET, IMPACT WRENCH, 3/8" DR, 6 PT, 16MM	1	J	3	34
SOCKET, IMPACT WRENCH, 3/8" DR, 6 PT, 17MM	1	J	3	35
SOCKET, IMPACT WRENCH, 3/8" DR, 6 PT, 18MM	1	J	3	36

TM 9-4910-783-13&P

SATS BASE TOOL COMPONENT LIST

0058 00

NOMENCLATURE	QTY	RACK	DRAWER	LOCATION
SOCKET, IMPACT WRENCH, 3/8" DR, 6 PT, 19MM	1	J	3	37
SOCKET, IMPACT WRENCH, 3/8" DR, 6 PT, 3/4"	1	J	3	46
SOCKET, IMPACT WRENCH, 3/8" DR, 6 PT, 3/8"	1	J	3	62
SOCKET, IMPACT WRENCH, 3/8" DR, 6 PT, 5/16"	1	J	3	67
SOCKET, IMPACT WRENCH, 3/8" DR, 6 PT, 5/8"	1	J	3	48
SOCKET, IMPACT WRENCH, 3/8" DR, 6 PT, 7/16"	1	J	3	51
SOCKET, IMPACT WRENCH, 3/8" DR, 6 PT, 9/16"	1	J	3	49
SOCKET, IMPACT WRENCH, 3/8" DR, 6 PT, DEEP, 1/2"	1	J	3	57
SOCKET, IMPACT WRENCH, 3/8" DR, 6 PT, DEEP, 1/4"	1	J	3	61
SOCKET, IMPACT WRENCH, 3/8" DR, 6 PT, DEEP, 10MM	1	J	3	27
SOCKET, IMPACT WRENCH, 3/8" DR, 6 PT, DEEP, 11/16"	1	J	3	54
SOCKET, IMPACT WRENCH, 3/8" DR, 6 PT, DEEP, 11MM	1	J	3	26
SOCKET, IMPACT WRENCH, 3/8" DR, 6 PT, DEEP, 12MM	1	J	3	25
SOCKET, IMPACT WRENCH, 3/8" DR, 6 PT, DEEP, 13MM	1	J	3	39
SOCKET, IMPACT WRENCH, 3/8" DR, 6 PT, DEEP, 14MM	1	J	3	40
SOCKET, IMPACT WRENCH, 3/8" DR, 6 PT, DEEP, 15MM	1	J	3	41
SOCKET, IMPACT WRENCH, 3/8" DR, 6 PT, DEEP, 16MM	1	J	3	42
SOCKET, IMPACT WRENCH, 3/8" DR, 6 PT, DEEP, 17MM	1	J	3	43
SOCKET, IMPACT WRENCH, 3/8" DR, 6 PT, DEEP, 18MM	1	J	3	44
SOCKET, IMPACT WRENCH, 3/8" DR, 6 PT, DEEP, 19MM	1	J	3	45
SOCKET, IMPACT WRENCH, 3/8" DR, 6 PT, DEEP, 3/4"	1	J	3	53
SOCKET, IMPACT WRENCH, 3/8" DR, 6 PT, DEEP, 3/8"	1	J	3	59
SOCKET, IMPACT WRENCH, 3/8" DR, 6 PT, DEEP, 5/16"	1	J	3	60
SOCKET, IMPACT WRENCH, 3/8" DR, 6 PT, DEEP, 5/8"	1	J	3	55
SOCKET, IMPACT WRENCH, 3/8" DR, 6 PT, DEEP, 7/16"	1	J	3	58
SOCKET, IMPACT WRENCH, 3/8" DR, 6 PT, DEEP, 9/16"	1	J	3	56
SOCKET, SOCKET WRENCH, 1/2" DR, 12 PT, DEEP, 10MM	1	K	2	95
SOCKET, SOCKET WRENCH, 1/2" DR, 12 PT, DEEP, 11MM	1	K	2	94
SOCKET, SOCKET WRENCH, 1/2" DR, 12 PT, DEEP, 12MM	1	K	2	93
SOCKET, SOCKET WRENCH, 1/2" DR, 12 PT, DEEP, 13MM	1	K	2	92
SOCKET, SOCKET WRENCH, 1/2" DR, 12 PT, DEEP, 14MM	1	K	2	91
SOCKET, SOCKET WRENCH, 1/2" DR, 12 PT, DEEP, 15MM	1	K	2	90
SOCKET, SOCKET WRENCH, 1/2" DR, 12 PT, DEEP, 16MM	1	K	2	89
SOCKET, SOCKET WRENCH, 1/2" DR, 12 PT, DEEP, 17MM	1	K	2	88
SOCKET, SOCKET WRENCH, 1/2" DR, 12 PT, DEEP, 18MM	1	K	2	87
SOCKET, SOCKET WRENCH, 1/2" DR, 12 PT, DEEP, 19MM	1	K	2	86
SOCKET, SOCKET WRENCH, 1/2" DR, 12 PT, DEEP, 20MM	1	K	2	98
SOCKET, SOCKET WRENCH, 1/2" DR, 12 PT, DEEP, 21MM	1	K	2	99

TM 9-4910-783-13&P

SATS BASE TOOL COMPONENT LIST

0058 00

NOMENCLATURE	QTY	RACK	DRAWER	LOCATION
SOCKET, SOCKET WRENCH, 1/2" DR, 12 PT, DEEP, 22MM	1	K	2	100
SOCKET, SOCKET WRENCH, 1/2" DR, 12 PT, DEEP, 23MM	1	K	2	101
SOCKET, SOCKET WRENCH, 1/2" DR, 12 PT, DEEP, 24MM	1	K	2	102
SOCKET, SOCKET WRENCH, 1/2" DR, 12 PT, DEEP, 25MM	1	K	2	103
SOCKET, SOCKET WRENCH, 1/2" DR, 12 PT, DEEP, 26MM	1	K	2	104
SOCKET, SOCKET WRENCH, 1/2" DR, 12 PT, DEEP, 27MM	1	K	2	105
SOCKET, SOCKET WRENCH, 1/2" DR, 12 PT, DEEP, 28MM	1	K	2	106
SOCKET, SOCKET WRENCH, 1/2" DR, 12 PT, DEEP, 29MM	1	K	2	107
SOCKET, SOCKET WRENCH, 1/2" DR, 12 PT, DEEP, 30MM	1	K	2	108
SOCKET, SOCKET WRENCH, 1/2" DR, 12 PT, DEEP, 32MM	1	K	2	109
SOCKET, SOCKET WRENCH, 1/2" DR, 12 PT, REGULAR, 19/32"	1	K	2	83
SOCKET, SOCKET WRENCH, 1/2" DR, 12 PT, REGULAR, 21/32"	1	K	2	70
SOCKET, SOCKET WRENCH, 1/2" DR, 12 PT, REGULAR, 25/32"	1	K	2	59
SOCKET, SOCKET WRENCH, 1/2" DR, 6 PT, DEEP, 1"	1	K	3	115
SOCKET, SOCKET WRENCH, 1/2" DR, 6 PT, DEEP, 1/2"	1	K	3	82
SOCKET, SOCKET WRENCH, 1/2" DR, 6 PT, DEEP, 11/16"	1	K	3	85
SOCKET, SOCKET WRENCH, 1/2" DR, 6 PT, DEEP, 1-1/16"	1	K	3	114
SOCKET, SOCKET WRENCH, 1/2" DR, 6 PT, DEEP, 1-1/2"	1	K	3	107
SOCKET, SOCKET WRENCH, 1/2" DR, 6 PT, DEEP, 1-1/4"	1	K	3	111
SOCKET, SOCKET WRENCH, 1/2" DR, 6 PT, DEEP, 1-1/8"	1	K	3	113
SOCKET, SOCKET WRENCH, 1/2" DR, 6 PT, DEEP, 13/16"	1	K	3	87
SOCKET, SOCKET WRENCH, 1/2" DR, 6 PT, DEEP, 1-3/16"	1	K	3	112
SOCKET, SOCKET WRENCH, 1/2" DR, 6 PT, DEEP, 1-3/8"	1	K	3	109
SOCKET, SOCKET WRENCH, 1/2" DR, 6 PT, DEEP, 15/16"	1	K	3	116
SOCKET, SOCKET WRENCH, 1/2" DR, 6 PT, DEEP, 1-5/16"	1	K	3	110
SOCKET, SOCKET WRENCH, 1/2" DR, 6 PT, DEEP, 1-7/16"	1	K	3	108
SOCKET, SOCKET WRENCH, 1/2" DR, 6 PT, DEEP, 3/4"	1	K	3	86
SOCKET, SOCKET WRENCH, 1/2" DR, 6 PT, DEEP, 3/8"	1	K	3	80
SOCKET, SOCKET WRENCH, 1/2" DR, 6 PT, DEEP, 7/8"	1	K	3	88
SOCKET, SOCKET WRENCH, 1/2" DR, 6 PT, DEEP, 9/16"	1	K	3	83
SOCKET, SOCKET WRENCH, 1/2" DR, 6 PT, REGULAR, 1"	1	K	3	98
SOCKET, SOCKET WRENCH, 1/2" DR, 6 PT, REGULAR, 1/2"	1	K	3	94
SOCKET, SOCKET WRENCH, 1/2" DR, 6 PT, REGULAR, 10MM	1	K	2	85
SOCKET, SOCKET WRENCH, 1/2" DR, 6 PT, REGULAR, 11/16"	1	K	3	91
SOCKET, SOCKET WRENCH, 1/2" DR, 6 PT, REGULAR, 1-1/16"	1	K	3	99
SOCKET, SOCKET WRENCH, 1/2" DR, 6 PT, REGULAR, 1-1/2"	1	K	3	106
SOCKET, SOCKET WRENCH, 1/2" DR, 6 PT, REGULAR, 1-1/4"	1	K	3	102
SOCKET, SOCKET WRENCH, 1/2" DR, 6 PT, REGULAR, 1-1/8"	1	K	3	100

TM 9-4910-783-13&P

SATS BASE TOOL COMPONENT LIST

0058 00

NOMENCLATURE	QTY	RACK	DRAWER	LOCATION
SOCKET, SOCKET WRENCH, 1/2" DR, 6 PT, REGULAR, 11MM	1	K	2	82
SOCKET, SOCKET WRENCH, 1/2" DR, 6 PT, REGULAR, 12MM	1	K	2	81
SOCKET, SOCKET WRENCH, 1/2" DR, 6 PT, REGULAR, 13/16"	1	K	3	89
SOCKET, SOCKET WRENCH, 1/2" DR, 6 PT, REGULAR, 1-3/16"	1	K	3	101
SOCKET, SOCKET WRENCH, 1/2" DR, 6 PT, REGULAR, 1-3/8"	1	K	3	104
SOCKET, SOCKET WRENCH, 1/2" DR, 6 PT, REGULAR, 13MM	1	K	2	80
SOCKET, SOCKET WRENCH, 1/2" DR, 6 PT, REGULAR, 14MM	1	K	2	79
SOCKET, SOCKET WRENCH, 1/2" DR, 6 PT, REGULAR, 15/16"	1	K	3	97
SOCKET, SOCKET WRENCH, 1/2" DR, 6 PT, REGULAR, 15MM	1	K	2	78
SOCKET, SOCKET WRENCH, 1/2" DR, 6 PT, REGULAR, 16MM	1	K	2	77
SOCKET, SOCKET WRENCH, 1/2" DR, 6 PT, REGULAR, 1-7/16"	1	K	3	105
SOCKET, SOCKET WRENCH, 1/2" DR, 6 PT, REGULAR, 17MM	1	K	2	76
SOCKET, SOCKET WRENCH, 1/2" DR, 6 PT, REGULAR, 18MM	1	K	2	75
SOCKET, SOCKET WRENCH, 1/2" DR, 6 PT, REGULAR, 19MM	1	K	2	74
SOCKET, SOCKET WRENCH, 1/2" DR, 6 PT, REGULAR, 21MM	1	K	2	73
SOCKET, SOCKET WRENCH, 1/2" DR, 6 PT, REGULAR, 22MM	1	K	2	72
SOCKET, SOCKET WRENCH, 1/2" DR, 6 PT, REGULAR, 23MM	1	K	2	71
SOCKET, SOCKET WRENCH, 1/2" DR, 6 PT, REGULAR, 24MM	1	K	2	60
SOCKET, SOCKET WRENCH, 1/2" DR, 6 PT, REGULAR, 25MM	1	K	2	61
SOCKET, SOCKET WRENCH, 1/2" DR, 6 PT, REGULAR, 26MM	1	K	2	62
SOCKET, SOCKET WRENCH, 1/2" DR, 6 PT, REGULAR, 27MM	1	K	2	63
SOCKET, SOCKET WRENCH, 1/2" DR, 6 PT, REGULAR, 28MM	1	K	2	64
SOCKET, SOCKET WRENCH, 1/2" DR, 6 PT, REGULAR, 29MM	1	K	2	65
SOCKET, SOCKET WRENCH, 1/2" DR, 6 PT, REGULAR, 3/4"	1	K	3	90
SOCKET, SOCKET WRENCH, 1/2" DR, 6 PT, REGULAR, 3/8"	1	K	3	79
SOCKET, SOCKET WRENCH, 1/2" DR, 6 PT, REGULAR, 30MM	1	K	2	66
SOCKET, SOCKET WRENCH, 1/2" DR, 6 PT, REGULAR, 32MM	1	K	2	67
SOCKET, SOCKET WRENCH, 1/2" DR, 6 PT, REGULAR, 36MM	1	K	2	68
SOCKET, SOCKET WRENCH, 1/2" DR, 6 PT, REGULAR, 5/8"	1	K	3	92
SOCKET, SOCKET WRENCH, 1/2" DR, 6 PT, REGULAR, 7/16"	1	K	3	95
SOCKET, SOCKET WRENCH, 1/2" DR, 6 PT, REGULAR, 7/8"	1	K	3	96
SOCKET, SOCKET WRENCH, 1/2" DR, 6 PT, REGULAR, 9/16"	1	K	3	93
SOCKET, SOCKET WRENCH, 1/2" DR, 6 PT, REGULAR, 9MM	1	K	2	84
SOCKET, SOCKET WRENCH, 1/2" DR, 6 PT, REGULAR, 1-5/16"	1	K	3	103
SOCKET, SOCKET WRENCH, 1/4" DR, 6 PT, DEEP, 1/2"	1	K	2	31
SOCKET, SOCKET WRENCH, 1/4" DR, 6 PT, DEEP, 1/4"	1	K	2	25
SOCKET, SOCKET WRENCH, 1/4" DR, 6 PT, DEEP, 1/8"	1	K	2	21
SOCKET, SOCKET WRENCH, 1/4" DR, 6 PT, DEEP, 10MM	1	K	2	9

TM 9-4910-783-13&P

SATS BASE TOOL COMPONENT LIST

0058 00

NOMENCLATURE	QTY	RACK	DRAWER	LOCATION
SOCKET, SOCKET WRENCH, 1/4" DR, 6 PT, DEEP, 11/32"	1	K	2	28
SOCKET, SOCKET WRENCH, 1/4" DR, 6 PT, DEEP, 11MM	1	K	2	10
SOCKET, SOCKET WRENCH, 1/4" DR, 6 PT, DEEP, 12MM	1	K	2	11
SOCKET, SOCKET WRENCH, 1/4" DR, 6 PT, DEEP, 13MM	1	K	2	12
SOCKET, SOCKET WRENCH, 1/4" DR, 6 PT, DEEP, 14MM	1	K	2	13
SOCKET, SOCKET WRENCH, 1/4" DR, 6 PT, DEEP, 15MM	1	K	2	14
SOCKET, SOCKET WRENCH, 1/4" DR, 6 PT, DEEP, 3/16"	1	K	2	23
SOCKET, SOCKET WRENCH, 1/4" DR, 6 PT, DEEP, 3/8"	1	K	2	29
SOCKET, SOCKET WRENCH, 1/4" DR, 6 PT, DEEP, 4.5MM	1	K	2	2
SOCKET, SOCKET WRENCH, 1/4" DR, 6 PT, DEEP, 4MM	1	K	2	1
SOCKET, SOCKET WRENCH, 1/4" DR, 6 PT, DEEP, 5.5MM	1	K	2	4
SOCKET, SOCKET WRENCH, 1/4" DR, 6 PT, DEEP, 5/16"	1	K	2	27
SOCKET, SOCKET WRENCH, 1/4" DR, 6 PT, DEEP, 5/32"	1	K	2	22
SOCKET, SOCKET WRENCH, 1/4" DR, 6 PT, DEEP, 5MM	1	K	2	3
SOCKET, SOCKET WRENCH, 1/4" DR, 6 PT, DEEP, 6MM	1	K	2	5
SOCKET, SOCKET WRENCH, 1/4" DR, 6 PT, DEEP, 7/16"	1	K	2	30
SOCKET, SOCKET WRENCH, 1/4" DR, 6 PT, DEEP, 7/32"	1	K	2	24
SOCKET, SOCKET WRENCH, 1/4" DR, 6 PT, DEEP, 7MM	1	K	2	6
SOCKET, SOCKET WRENCH, 1/4" DR, 6 PT, DEEP, 8MM	1	K	2	7
SOCKET, SOCKET WRENCH, 1/4" DR, 6 PT, DEEP, 9/16"	1	K	2	32
SOCKET, SOCKET WRENCH, 1/4" DR, 6 PT, DEEP, 9/32"	1	K	2	26
SOCKET, SOCKET WRENCH, 1/4" DR, 6 PT, DEEP, 9MM	1	K	2	8
SOCKET, SOCKET WRENCH, 1/4" DR, 6 PT, REGULAR, 1/2"	1	K	2	34
SOCKET, SOCKET WRENCH, 1/4" DR, 6 PT, REGULAR, 1/4"	1	K	2	40
SOCKET, SOCKET WRENCH, 1/4" DR, 6 PT, REGULAR, 1/8"	1	K	2	44
SOCKET, SOCKET WRENCH, 1/4" DR, 6 PT, REGULAR, 10MM	1	K	2	53
SOCKET, SOCKET WRENCH, 1/4" DR, 6 PT, REGULAR, 11/32"	1	K	2	37
SOCKET, SOCKET WRENCH, 1/4" DR, 6 PT, REGULAR, 11MM	1	K	2	54
SOCKET, SOCKET WRENCH, 1/4" DR, 6 PT, REGULAR, 12MM	1	K	2	55
SOCKET, SOCKET WRENCH, 1/4" DR, 6 PT, REGULAR, 13MM	1	K	2	56
SOCKET, SOCKET WRENCH, 1/4" DR, 6 PT, REGULAR, 14MM	1	K	2	57
SOCKET, SOCKET WRENCH, 1/4" DR, 6 PT, REGULAR, 15MM	1	K	2	58
SOCKET, SOCKET WRENCH, 1/4" DR, 6 PT, REGULAR, 3/16"	1	K	2	42
SOCKET, SOCKET WRENCH, 1/4" DR, 6 PT, REGULAR, 3/8"	1	K	2	36
SOCKET, SOCKET WRENCH, 1/4" DR, 6 PT, REGULAR, 4.5MM	1	K	2	51
SOCKET, SOCKET WRENCH, 1/4" DR, 6 PT, REGULAR, 4MM	1	K	2	52
SOCKET, SOCKET WRENCH, 1/4" DR, 6 PT, REGULAR, 5.5MM	1	K	2	49
SOCKET, SOCKET WRENCH, 1/4" DR, 6 PT, REGULAR, 5/16"	1	K	2	38

TM 9-4910-783-13&P

SATS BASE TOOL COMPONENT LIST

0058 00

NOMENCLATURE	QTY	RACK	DRAWER	LOCATION
SOCKET, SOCKET WRENCH, 1/4" DR, 6 PT, REGULAR, 5/32"	1	K	2	43
SOCKET, SOCKET WRENCH, 1/4" DR, 6 PT, REGULAR, 5MM	1	K	2	50
SOCKET, SOCKET WRENCH, 1/4" DR, 6 PT, REGULAR, 6MM	1	K	2	48
SOCKET, SOCKET WRENCH, 1/4" DR, 6 PT, REGULAR, 7/16"	1	K	2	35
SOCKET, SOCKET WRENCH, 1/4" DR, 6 PT, REGULAR, 7/32"	1	K	2	41
SOCKET, SOCKET WRENCH, 1/4" DR, 6 PT, REGULAR, 7MM	1	K	2	47
SOCKET, SOCKET WRENCH, 1/4" DR, 6 PT, REGULAR, 8MM	1	K	2	46
SOCKET, SOCKET WRENCH, 1/4" DR, 6 PT, REGULAR, 9/16"	1	K	2	33
SOCKET, SOCKET WRENCH, 1/4" DR, 6 PT, REGULAR, 9/32"	1	K	2	39
SOCKET, SOCKET WRENCH, 1/4" DR, 6 PT, REGULAR, 9MM	1	K	2	45
SOCKET, SOCKET WRENCH, 3/4" DR, 12 PT, 1-1/16"	1	J	5	4
SOCKET, SOCKET WRENCH, 3/4" DR, 12 PT, 1-1/2"	1	J	5	21
SOCKET, SOCKET WRENCH, 3/4" DR, 12 PT, 1-1/4"	1	J	5	13
SOCKET, SOCKET WRENCH, 3/4" DR, 12 PT, 1-1/8"	1	J	5	12
SOCKET, SOCKET WRENCH, 3/4" DR, 12 PT, 1-13/16"	1	J	5	22
SOCKET, SOCKET WRENCH, 3/4" DR, 12 PT, 1-3/4"	1	J	5	17
SOCKET, SOCKET WRENCH, 3/4" DR, 12 PT, 1-3/8"	1	J	5	15
SOCKET, SOCKET WRENCH, 3/4" DR, 12 PT, 1-5/16"	1	J	5	14
SOCKET, SOCKET WRENCH, 3/4" DR, 12 PT, 1-5/8"	1	J	5	19
SOCKET, SOCKET WRENCH, 3/4" DR, 12 PT, 1-7/16"	1	J	5	16
SOCKET, SOCKET WRENCH, 3/4" DR, 12 PT, 1-7/8"	1	J	5	23
SOCKET, SOCKET WRENCH, 3/4" DR, 12 PT, 1-9/16"	1	J	5	20
SOCKET, SOCKET WRENCH, 3/4" DR, 12 PT, 1"	1	J	5	5
SOCKET, SOCKET WRENCH, 3/4" DR, 12 PT, 15/16"	1	J	5	6
SOCKET, SOCKET WRENCH, 3/4" DR, 12 PT, 2-1/16"	1	J	5	25
SOCKET, SOCKET WRENCH, 3/4" DR, 12 PT, 2-1/4"	1	J	5	28
SOCKET, SOCKET WRENCH, 3/4" DR, 12 PT, 2-1/8"	1	J	5	26
SOCKET, SOCKET WRENCH, 3/4" DR, 12 PT, 2-3/16"	1	J	5	27
SOCKET, SOCKET WRENCH, 3/4" DR, 12 PT, 2-3/8"	1	J	5	29
SOCKET, SOCKET WRENCH, 3/4" DR, 12 PT, 2"	1	J	5	24
SOCKET, SOCKET WRENCH, 3/4" DR, 12 PT, 7/8"	1	J	5	7
SOCKET, SOCKET WRENCH, 3/4" DR, 12 PT, 1-11/16"	1	J	5	18
SOCKET, SOCKET WRENCH, 3/8" DR, 6 PT, DEEP, 1"	1	K	3	22
SOCKET, SOCKET WRENCH, 3/8" DR, 6 PT, DEEP, 1/2"	1	K	3	30
SOCKET, SOCKET WRENCH, 3/8" DR, 6 PT, DEEP, 1/4"	1	K	3	34
SOCKET, SOCKET WRENCH, 3/8" DR, 6 PT, DEEP, 10MM	1	K	3	20
SOCKET, SOCKET WRENCH, 3/8" DR, 6 PT, DEEP, 11/16"	1	K	3	27
SOCKET, SOCKET WRENCH, 3/8" DR, 6 PT, DEEP, 11MM	1	K	3	19

TM 9-4910-783-13&P

SATS BASE TOOL COMPONENT LIST

0058 00

NOMENCLATURE	QTY	RACK	DRAWER	LOCATION
SOCKET, SOCKET WRENCH, 3/8" DR, 6 PT, DEEP, 12MM	1	K	3	18
SOCKET, SOCKET WRENCH, 3/8" DR, 6 PT, DEEP, 13/16"	1	K	3	25
SOCKET, SOCKET WRENCH, 3/8" DR, 6 PT, DEEP, 13MM	1	K	3	17
SOCKET, SOCKET WRENCH, 3/8" DR, 6 PT, DEEP, 14MM	1	K	3	16
SOCKET, SOCKET WRENCH, 3/8" DR, 6 PT, DEEP, 15/16"	1	K	3	23
SOCKET, SOCKET WRENCH, 3/8" DR, 6 PT, DEEP, 15MM	1	K	3	15
SOCKET, SOCKET WRENCH, 3/8" DR, 6 PT, DEEP, 16MM	1	K	3	14
SOCKET, SOCKET WRENCH, 3/8" DR, 6 PT, DEEP, 17MM	1	K	3	13
SOCKET, SOCKET WRENCH, 3/8" DR, 6 PT, DEEP, 18MM	1	K	3	12
SOCKET, SOCKET WRENCH, 3/8" DR, 6 PT, DEEP, 19MM	1	K	3	11
SOCKET, SOCKET WRENCH, 3/8" DR, 6 PT, DEEP, 20MM	1	K	3	10
SOCKET, SOCKET WRENCH, 3/8" DR, 6 PT, DEEP, 21MM	1	K	3	9
SOCKET, SOCKET WRENCH, 3/8" DR, 6 PT, DEEP, 22MM	1	K	3	8
SOCKET, SOCKET WRENCH, 3/8" DR, 6 PT, DEEP, 23MM	1	K	3	7
SOCKET, SOCKET WRENCH, 3/8" DR, 6 PT, DEEP, 26MM	1	K	3	6
SOCKET, SOCKET WRENCH, 3/8" DR, 6 PT, DEEP, 3/4"	1	K	3	26
SOCKET, SOCKET WRENCH, 3/8" DR, 6 PT, DEEP, 3/8"	1	K	3	32
SOCKET, SOCKET WRENCH, 3/8" DR, 6 PT, DEEP, 5/16"	1	K	3	33
SOCKET, SOCKET WRENCH, 3/8" DR, 6 PT, DEEP, 5/8"	1	K	3	28
SOCKET, SOCKET WRENCH, 3/8" DR, 6 PT, DEEP, 6MM	1	K	3	35
SOCKET, SOCKET WRENCH, 3/8" DR, 6 PT, DEEP, 7/16"	1	K	3	31
SOCKET, SOCKET WRENCH, 3/8" DR, 6 PT, DEEP, 7/8"	1	K	3	24
SOCKET, SOCKET WRENCH, 3/8" DR, 6 PT, DEEP, 7MM	1	K	3	36
SOCKET, SOCKET WRENCH, 3/8" DR, 6 PT, DEEP, 8MM	1	K	3	37
SOCKET, SOCKET WRENCH, 3/8" DR, 6 PT, DEEP, 9/16"	1	K	3	29
SOCKET, SOCKET WRENCH, 3/8" DR, 6 PT, DEEP, 9MM	1	K	3	21
SOCKET, SOCKET WRENCH, 3/8" DR, 6 PT, REGULAR, 1"	1	K	3	57
SOCKET, SOCKET WRENCH, 3/8" DR, 6 PT, REGULAR, 1/2"	1	K	3	65
SOCKET, SOCKET WRENCH, 3/8" DR, 6 PT, REGULAR, 1/4"	1	K	3	69
SOCKET, SOCKET WRENCH, 3/8" DR, 6 PT, REGULAR, 10MM	1	K	3	42
SOCKET, SOCKET WRENCH, 3/8" DR, 6 PT, REGULAR, 11/16"	1	K	3	62
SOCKET, SOCKET WRENCH, 3/8" DR, 6 PT, REGULAR, 11MM	1	K	3	43
SOCKET, SOCKET WRENCH, 3/8" DR, 6 PT, REGULAR, 12MM	1	K	3	44
SOCKET, SOCKET WRENCH, 3/8" DR, 6 PT, REGULAR, 13/16"	1	K	3	60
SOCKET, SOCKET WRENCH, 3/8" DR, 6 PT, REGULAR, 13MM	1	K	3	45
SOCKET, SOCKET WRENCH, 3/8" DR, 6 PT, REGULAR, 14MM	1	K	3	46
SOCKET, SOCKET WRENCH, 3/8" DR, 6 PT, REGULAR, 15/16"	1	K	3	58
SOCKET, SOCKET WRENCH, 3/8" DR, 6 PT, REGULAR, 15MM	1	K	3	47

TM 9-4910-783-13&P

SATS BASE TOOL COMPONENT LIST

0058 00

NOMENCLATURE	QTY	RACK	DRAWER	LOCATION
SOCKET, SOCKET WRENCH, 3/8" DR, 6 PT, REGULAR, 16MM	1	K	3	48
SOCKET, SOCKET WRENCH, 3/8" DR, 6 PT, REGULAR, 17MM	1	K	3	49
SOCKET, SOCKET WRENCH, 3/8" DR, 6 PT, REGULAR, 18MM	1	K	3	50
SOCKET, SOCKET WRENCH, 3/8" DR, 6 PT, REGULAR, 19MM	1	K	3	51
SOCKET, SOCKET WRENCH, 3/8" DR, 6 PT, REGULAR, 20MM	1	K	3	52
SOCKET, SOCKET WRENCH, 3/8" DR, 6 PT, REGULAR, 21MM	1	K	3	53
SOCKET, SOCKET WRENCH, 3/8" DR, 6 PT, REGULAR, 22MM	1	K	3	54
SOCKET, SOCKET WRENCH, 3/8" DR, 6 PT, REGULAR, 23MM	1	K	3	55
SOCKET, SOCKET WRENCH, 3/8" DR, 6 PT, REGULAR, 26MM	1	K	3	56
SOCKET, SOCKET WRENCH, 3/8" DR, 6 PT, REGULAR, 3/4"	1	K	3	61
SOCKET, SOCKET WRENCH, 3/8" DR, 6 PT, REGULAR, 3/8"	1	K	3	67
SOCKET, SOCKET WRENCH, 3/8" DR, 6 PT, REGULAR, 5/16"	1	K	3	68
SOCKET, SOCKET WRENCH, 3/8" DR, 6 PT, REGULAR, 5/8"	1	K	3	63
SOCKET, SOCKET WRENCH, 3/8" DR, 6 PT, REGULAR, 6MM	1	K	3	38
SOCKET, SOCKET WRENCH, 3/8" DR, 6 PT, REGULAR, 7/16"	1	K	3	66
SOCKET, SOCKET WRENCH, 3/8" DR, 6 PT, REGULAR, 7/8"	1	K	3	59
SOCKET, SOCKET WRENCH, 3/8" DR, 6 PT, REGULAR, 7MM	1	K	3	39
SOCKET, SOCKET WRENCH, 3/8" DR, 6 PT, REGULAR, 8MM	1	K	3	40
SOCKET, SOCKET WRENCH, 3/8" DR, 6 PT, REGULAR, 9/16"	1	K	3	64
SOCKET, SOCKET WRENCH, 3/8" DR, 6 PT, REGULAR, 9MM	1	K	3	41
SOCKET, SOCKET WRENCH, UNIVERSAL, 3/8" DR, 6 PT, 1/2"	1	J	4	42
SOCKET, SOCKET WRENCH, UNIVERSAL, 3/8" DR, 6 PT, 10MM	1	J	4	13
SOCKET, SOCKET WRENCH, UNIVERSAL, 3/8" DR, 6 PT, 11/16"	1	J	4	29
SOCKET, SOCKET WRENCH, UNIVERSAL, 3/8" DR, 6 PT, 11MM	1	J	4	12
SOCKET, SOCKET WRENCH, UNIVERSAL, 3/8" DR, 6 PT, 12MM	1	J	4	11
SOCKET, SOCKET WRENCH, UNIVERSAL, 3/8" DR, 6 PT, 13MM	1	J	4	10
SOCKET, SOCKET WRENCH, UNIVERSAL, 3/8" DR, 6 PT, 14MM	1	J	4	9
SOCKET, SOCKET WRENCH, UNIVERSAL, 3/8" DR, 6 PT, 15MM	1	J	4	8
SOCKET, SOCKET WRENCH, UNIVERSAL, 3/8" DR, 6 PT, 16MM	1	J	4	7
SOCKET, SOCKET WRENCH, UNIVERSAL, 3/8" DR, 6 PT, 17MM	1	J	4	6
SOCKET, SOCKET WRENCH, UNIVERSAL, 3/8" DR, 6 PT, 18MM	1	J	4	5
SOCKET, SOCKET WRENCH, UNIVERSAL, 3/8" DR, 6 PT, 19MM	1	J	4	4
SOCKET, SOCKET WRENCH, UNIVERSAL, 3/8" DR, 6 PT, 21MM	1	J	4	3
SOCKET, SOCKET WRENCH, UNIVERSAL, 3/8" DR, 6 PT, 22MM	1	J	4	2
SOCKET, SOCKET WRENCH, UNIVERSAL, 3/8" DR, 6 PT, 24MM	1	J	4	1
SOCKET, SOCKET WRENCH, UNIVERSAL, 3/8" DR, 6 PT, 3/4"	1	J	4	16
SOCKET, SOCKET WRENCH, UNIVERSAL, 3/8" DR, 6 PT, 3/8"	1	J	4	62
SOCKET, SOCKET WRENCH, UNIVERSAL, 3/8" DR, 6 PT, 5/8"	1	J	4	30

TM 9-4910-783-13&P

SATS BASE TOOL COMPONENT LIST

0058 00

NOMENCLATURE	QTY	RACK	DRAWER	LOCATION
SOCKET, SOCKET WRENCH, UNIVERSAL, 3/8" DR, 6 PT, 7/16"	1	J	4	56
SOCKET, SOCKET WRENCH, UNIVERSAL, 3/8" DR, 6 PT, 7MM	1	J	4	15
SOCKET, SOCKET WRENCH, UNIVERSAL, 3/8" DR, 6 PT, 8MM	1	J	4	14
SOCKET, SOCKET WRENCH, UNIVERSAL, 3/8" DR, 6 PT, 9/16"	1	J	4	41
SOCKET, SOCKET WRENCH, WHEEL BEARING LOCKNUT, 3/4" DR, 6 PT, 2-3/32"	1	J	6	9
SOCKET, SOCKET WRENCH, WHEEL BEARING LOCKNUT, 3/4" DR, 6 PT, 2-3/8"	1	J	6	10
SOCKET, SOCKET WRENCH, WHEEL BEARING LOCKNUT, 3/4" DR, 6 PT, 3"	1	J	6	14
SOCKET, SOCKET WRENCH, WHEEL BEARING LOCKNUT, 3/4" DR, 6 PT, 3-1/2"	1	J	6	12
SOCKET, SOCKET WRENCH, WHEEL BEARING LOCKNUT, 3/4" DR, 6 PT, 3-1/4"	1	J	6	13
SOCKET, SOCKET WRENCH, WHEEL BEARING LOCKNUT, 3/4" DR, 6 PT, 3-7/8"	1	J	6	11
SOCKET, SOCKET WRENCH, WHEEL BEARING LOCKNUT, 3/4" DR, 6 PT, 4"	1	J	6	16
SOCKET, SOCKET WRENCH, WHEEL BEARING LOCKNUT, 3/4" DR, 6 PT, 4-1/8"	1	J	6	17
SOCKET, SOCKET WRENCH, WHEEL BEARING LOCKNUT, 3/4" DR, 6 PT, 4-3/8"	1	J	6	18
SOCKET, SOCKET WRENCH, WHEEL BEARING LOCKNUT, 3/4" DR, 6 PT, 4-7/8"	1	J	6	19
SOCKET, SOCKET WRENCH, WHEEL BEARING LOCKNUT, 3/4" DR, 6 PT, 2-9/16"	1	J	6	15
SOCKET, SOCKET WRENCH, WHEEL BEARING LOCKNUT, 3/4" DR, 8 PT, 2-9/16"	1	J	6	7
SOCKET, SOCKET WRENCH, WHEEL BEARING LOCKNUT, 3/4" DR, 8 PT, 3"	1	J	6	6
SOCKET, SOCKET WRENCH, WHEEL BEARING LOCKNUT, 3/4" DR, 8 PT, 3-1/2"	1	J	6	1
SOCKET, SOCKET WRENCH, WHEEL BEARING LOCKNUT, 3/4" DR, 8 PT, 3-1/4"	1	J	6	5
SOCKET, SOCKET WRENCH, WHEEL BEARING LOCKNUT, 3/4" DR, 8 PT, 3-7/8"	1	J	6	2
SOCKET, SOCKET WRENCH, WHEEL BEARING LOCKNUT, 3/4" DR, 8 PT, 4-3/8"	1	J	6	3
SOCKET, SOCKET WRENCH, WHEEL BEARING LOCKNUT, 3/4" DR, 8 PT, 4-7/8"	1	J	6	4
SOCKET, SOCKET WRENCH, WHEEL BEARING LOCKNUT, 3/4" DR, 8 PT, 2-3/8"	1	J	6	8
SOLDERING GUN	1	J	10	3
SPLITTING TOOL, NUT	1	K	5	7
STEERING WHEEL PULLER	1	H	2	11
STEP PLATE ADAPTER, 1-1/8"	1	H	2	22
STEP PLATE ADAPTER, 1-1/4"	1	H	2	24
STEP PLATE ADAPTER, 1-3/4"	1	H	2	16
STEP PLATE ADAPTER, 1-3/8"	1	H	2	26
STEP PLATE ADAPTER, 1-5/8"	1	H	2	20
STEP PLATE ADAPTER, 1-7/8"	1	H	2	12
STEP PLATE ADAPTER, 1"	1	H	2	19
STEP PLATE ADAPTER, 2-1/2"	1	H	2	9
STEP PLATE ADAPTER, 2-1/8"	1	H	2	13
STEP PLATE ADAPTER, 2-3/8"	1	H	2	10
STUD REMOVER, 5/16" - 3/4" CAPACITY	1	K	3	78
TAPE, MEASURING, 25'	1	J	9	1

TM 9-4910-783-13&P

SATS BASE TOOL COMPONENT LIST

0058 00

NOMENCLATURE	QTY	RACK	DRAWER	LOCATION
TEST KIT, RADIATOR PRESSURE	1	H	5	3
TESTER, ANTIFREEZE SOLUTION	1	H	5	1,9
TOOL KIT, BLIND, FASTENER, INSTALLATION	1	J	9	2
TOOL KIT, CUTTING, ABRASIVE, PNEUMATIC	1	K	8	1
TOOL KIT, SCREW INSERT	1	J	8	4
TOOL KIT, TIRE SERVICE	1	M		4
TRESTLE, HOIST, PORTABLE (NOTE: GFE ITEM)	4	Q		3
TRUCK, LIFT, WHEEL	1	A		1
WISE, MACHINIST'S, 4 INCH	1	B	2	1
WHEEL, ABRASIVE, COARSE, 90 GRIT (PROTOTYPE)	1	K	8	10
WHEEL, ABRASIVE, FINE, 36 GRIT (PROTOTYPE)	1	K	8	9
WHEEL, ABRASIVE, TYPE 27	1	K	8	8
WHEEL, ABRASIVE, TYPE 29 (PROTOTYPE)	1	K	8	7
WRENCH KIT, RATCHET, PNEUMATIC	2	K	7	1, 4
WRENCH, ADJUSTABLE, 10 INCH	2	L	11	19, 20
WRENCH, ADJUSTABLE, 18 INCH	2	L	11	17, 18
WRENCH, ADJUSTABLE, AUTOMOTIVE, 15 INCH	2	L	6	5, 6
WRENCH, ADJUSTABLE, AUTOMOTIVE, 18 INCH	2	L	6	3, 4
WRENCH, BOX, 12 PT, 1" X 1-1/16"	1	L	8	13
WRENCH, BOX, 12 PT, 1/2" X 9/16"	1	L	8	4
WRENCH, BOX, 12 PT, 10MM X 11MM	1	L	7	11
WRENCH, BOX, 12 PT, 1-1/16" X 1-1/4"	1	L	8	14
WRENCH, BOX, 12 PT, 11/16" X 3/4"	1	L	8	7
WRENCH, BOX, 12 PT, 1-1/2" X 1-5/8"	1	L	8	18
WRENCH, BOX, 12 PT, 1-1/4" X 1-5/16"	1	L	8	16
WRENCH, BOX, 12 PT, 1-1/8" X 1-3/16"	1	L	8	15
WRENCH, BOX, 12 PT, 12MM X 14MM	1	L	7	10
WRENCH, BOX, 12 PT, 13/16" X 7/8"	1	L	8	10
WRENCH, BOX, 12 PT, 1-3/8" X 1-7/16"	1	L	8	17
WRENCH, BOX, 12 PT, 14MM X 15MM	1	L	7	8
WRENCH, BOX, 12 PT, 15/16" X 1"	1	L	8	12
WRENCH, BOX, 12 PT, 16MM X 18MM	1	L	7	7
WRENCH, BOX, 12 PT, 17MM X 19MM	1	L	7	6
WRENCH, BOX, 12 PT, 18MM X 21MM	1	L	7	5
WRENCH, BOX, 12 PT, 19MM X 22MM	1	L	7	4
WRENCH, BOX, 12 PT, 22MM X 24MM	1	L	7	3
WRENCH, BOX, 12 PT, 27MM X 30MM	1	L	7	2
WRENCH, BOX, 12 PT, 3/4" X 13/16"	1	L	8	8

TM 9-4910-783-13&P

SATS BASE TOOL COMPONENT LIST

0058 00

NOMENCLATURE	QTY	RACK	DRAWER	LOCATION
WRENCH, BOX, 12 PT, 3/4" X 7/8"	1	L	8	9
WRENCH, BOX, 12 PT, 3/8" X 7/16"	1	L	8	2
WRENCH, BOX, 12 PT, 30MM X 32MM	1	L	7	1
WRENCH, BOX, 12 PT, 5/8" X 11/16"	1	L	8	5
WRENCH, BOX, 12 PT, 5/8" X 3/4"	1	L	8	6
WRENCH, BOX, 12 PT, 7/16" X 1/2"	1	L	8	3
WRENCH, BOX, 12 PT, 7/8" X 15/16"	1	L	8	11
WRENCH, BOX, 12 PT, 9/16" X 5/8"	1	L	8	1
WRENCH, BOX, 12 PT, 13MM X 15MM	1	L	7	9
WRENCH, COMBINATION, 1/2"	1	L	10	20
WRENCH, COMBINATION, 11/16"	1	L	10	13
WRENCH, COMBINATION, 1"	1	L	10	8
WRENCH, COMBINATION, 1/4"	1	L	10	16
WRENCH, COMBINATION, 10MM	1	L	9	1
WRENCH, COMBINATION, 1-1/16"	1	L	10	7
WRENCH, COMBINATION, 1-1/2"	1	L	10	1
WRENCH, COMBINATION, 1-1/4"	1	L	10	5
WRENCH, COMBINATION, 1-1/8"	1	L	10	6
WRENCH, COMBINATION, 1-11/16"	1	L	11	5
WRENCH, COMBINATION, 11MM	1	L	9	2
WRENCH, COMBINATION, 12MM	1	L	9	3
WRENCH, COMBINATION, 13/16"	1	L	10	11
WRENCH, COMBINATION, 1-3/4"	1	L	11	4
WRENCH, COMBINATION, 1-3/8"	1	L	10	3
WRENCH, COMBINATION, 13MM	1	L	9	4
WRENCH, COMBINATION, 14MM	1	L	9	5
WRENCH, COMBINATION, 1-5/16"	1	L	10	4
WRENCH, COMBINATION, 15/16"	1	L	10	9
WRENCH, COMBINATION, 1-5/8"	1	L	11	6
WRENCH, COMBINATION, 15MM	1	L	9	6
WRENCH, COMBINATION, 16MM	1	L	9	7
WRENCH, COMBINATION, 1-7/16"	1	L	10	2
WRENCH, COMBINATION, 1-7/8"	1	L	11	2
WRENCH, COMBINATION, 17MM	1	L	9	8
WRENCH, COMBINATION, 18MM	1	L	9	9
WRENCH, COMBINATION, 1-13/16"	1	L	11	3
WRENCH, COMBINATION, 19MM	1	L	9	10
WRENCH, COMBINATION, 2"	1	L	11	1

TM 9-4910-783-13&P

SATS BASE TOOL COMPONENT LIST

0058 00

NOMENCLATURE	QTY	RACK	DRAWER	LOCATION
WRENCH, COMBINATION, 20MM	1	L	9	11
WRENCH, COMBINATION, 21MM	1	L	9	12
WRENCH, COMBINATION, 22MM	1	L	9	13
WRENCH, COMBINATION, 23MM	1	L	9	14
WRENCH, COMBINATION, 24MM	1	L	9	15
WRENCH, COMBINATION, 25MM	1	L	9	16
WRENCH, COMBINATION, 26MM	1	L	9	17
WRENCH, COMBINATION, 27MM	1	L	9	18
WRENCH, COMBINATION, 28MM	1	L	9	19
WRENCH, COMBINATION, 29MM	1	L	9	20
WRENCH, COMBINATION, 3/4"	1	L	10	12
WRENCH, COMBINATION, 3/8"	1	L	10	18
WRENCH, COMBINATION, 30MM	1	L	9	21
WRENCH, COMBINATION, 32MM	1	L	9	22
WRENCH, COMBINATION, 36MM	1	L	9	23
WRENCH, COMBINATION, 5/16"	1	L	10	17
WRENCH, COMBINATION, 5/8"	1	L	10	14
WRENCH, COMBINATION, 7/16"	1	L	10	19
WRENCH, COMBINATION, 7/8"	1	L	10	10
WRENCH, COMBINATION, 7MM	1	L	9	24
WRENCH, COMBINATION, 8MM	1	L	9	25
WRENCH, COMBINATION, 9/16"	1	L	10	15
WRENCH, COMBINATION, 9MM	1	L	9	26
WRENCH, ELECTRIC IMPACT, 1/2" SQ DR,	1	J	3	82
WRENCH, FLARE NUT, 10MM X 12MM	1	L	7	30
WRENCH, FLARE NUT, 13MM X 14MM	1	L	7	29
WRENCH, FLARE NUT, 15MM X 17MM	1	L	7	28
WRENCH, FLARE NUT, 16MM X 18MM	1	L	7	27
WRENCH, FLARE NUT, 19MM X 21MM	1	L	7	26
WRENCH, FLARE NUT, 6 PT, 1/2" X 9/16"	1	L	11	12
WRENCH, FLARE NUT, 6 PT, 1/4" X 5/16"	1	L	11	16
WRENCH, FLARE NUT, 6 PT, 3/4" X 1"	1	L	11	8
WRENCH, FLARE NUT, 6 PT, 3/4" X 13/16"	1	L	11	9
WRENCH, FLARE NUT, 6 PT, 3/8" X 7/16"	1	L	11	14
WRENCH, FLARE NUT, 6 PT, 5/16" X 3/8"	1	L	11	15
WRENCH, FLARE NUT, 6 PT, 5/8" X 11/16"	1	L	11	11
WRENCH, FLARE NUT, 6 PT, 5/8" X 3/4"	1	L	11	10
WRENCH, FLARE NUT, 6 PT, 7/16" X 1/2"	1	L	11	13

TM 9-4910-783-13&P

SATS BASE TOOL COMPONENT LIST

0058 00

NOMENCLATURE	QTY	RACK	DRAWER	LOCATION
WRENCH, FLARE NUT, 6 PT, 7/8" X 1-1/8"	1	L	11	7
WRENCH, FLARE NUT, 9MM X 11MM	1	L	7	31
WRENCH, IMPACT, ELECTRIC, 3/4" SQUARE DRIVE HANDLE	1	J	1	3
WRENCH, IMPACT, PNEUMATIC, 3/4" SQUARE DRIVE, 1200 FT-LB	1	J	1	1
WRENCH, OIL FILTER	1	H	5	8
WRENCH, OIL FILTER, STRAP	1	H	5	2
WRENCH, OIL FILTER, STRAP	1	H	5	4
WRENCH, OPEN END, 1/2" X 9/16"	1	L	12	4
WRENCH, OPEN END, 1-1/16" X 1-1/8"	1	L	12	7
WRENCH, OPEN END, 11/16" X 3/4"	1	L	12	1
WRENCH, OPEN END, 1-1/2" X 1-5/8"	1	L	12	11
WRENCH, OPEN END, 1-1/4" X 1-5/16"	1	L	12	9
WRENCH, OPEN END, 1-11/16" X 1-13/16"	1	L	12	12
WRENCH, OPEN END, 13/16" X 7/8"	1	L	12	3
WRENCH, OPEN END, 1-3/8" X 1-7/16"	1	L	12	10
WRENCH, OPEN END, 15/16" X 1"	1	L	12	5
WRENCH, OPEN END, 1-7/8" X 2"	1	L	12	13
WRENCH, OPEN END, 3/8" X 7/16"	1	L	12	8
WRENCH, OPEN END, 5/8" X 3/4"	1	L	12	2
WRENCH, OPEN END, 7/16" X 1/2"	1	L	12	6
WRENCH, OPEN-END, 10MM X 11MM	1	L	7	14
WRENCH, OPEN-END, 12MM X 14MM	1	L	7	15
WRENCH, OPEN-END, 13MM X 15MM	1	L	7	16
WRENCH, OPEN-END, 16MM X 18MM	1	L	7	17
WRENCH, OPEN-END, 17MM X 19MM	1	L	7	18
WRENCH, OPEN-END, 20MM X 22MM	1	L	7	19
WRENCH, OPEN-END, 21MM X 23MM	1	L	7	21
WRENCH, OPEN-END, 22MM X 24MM	1	L	7	20
WRENCH, OPEN-END, 24MM X 26MM	1	L	7	22
WRENCH, OPEN-END, 25MM X 27MM	1	L	7	23
WRENCH, OPEN-END, 28MM X 30MM	1	L	7	24
WRENCH, OPEN-END, 30MM X 32MM	1	L	7	25
WRENCH, OPEN-END, 6MM X 8MM	1	L	7	12
WRENCH, OPEN-END, 7MM X 9MM	1	L	7	13
WRENCH, PIPE, 10 INCH	2	L	6	1,2
WRENCH, PIPE, 18 INCH	2	L	6	7, 8
WRENCH, PNEUMATIC IMPACT, 1/2" SQ DR,	1	J	3	92
WRENCH, TORQUE, CLICK, 1/2" DRIVE, 345 Nm	1	K	1	4

TM 9-4910-783-13&P

SATS BASE TOOL COMPONENT LIST

0058 00

NOMENCLATURE	QTY	RACK	DRAWER	LOCATION
WRENCH, TORQUE, CLICK, RATCHETING, 1/2" DRIVE, 250 FT-LB	1	K	1	5
WRENCH, TORQUE, CLICK, RATCHETING, 3/4" DRIVE, 600 FT-LB	1	P		8
WRENCH, TORQUE, CLICK, RATCHETING, 3/8" DRIVE, 75 FT-LB	1	K	1	6
WRENCH, TORQUE, DIAL, 1/4" DRIVE, 30 IN-LB	1	K	1	7
WRENCH, TORQUE, DIAL, 3/8" DRIVE, 300 IN-LB	1	K	1	2
WRENCH, WHEEL STUD NUT, GEARED SOCKET	1	P		3

TM 9-4910-783-13&P

SATS BASE TOOL INVENTORY LIST

0058 00

NOMENCLATURE					INVENTORY
	QTY	RACK	DRAWER	LOCATION	AMOUNT
TRUCK, LIFT, WHEEL	1	A		1	
FOUR FOOT RAMP	1	A		2	
HOSE ASSEMBLY, AIR, NONMETALLIC	2	A		5	
COMPRESSOR UNIT, RECIPROCATING	1	A		5	

A – Floor Positions

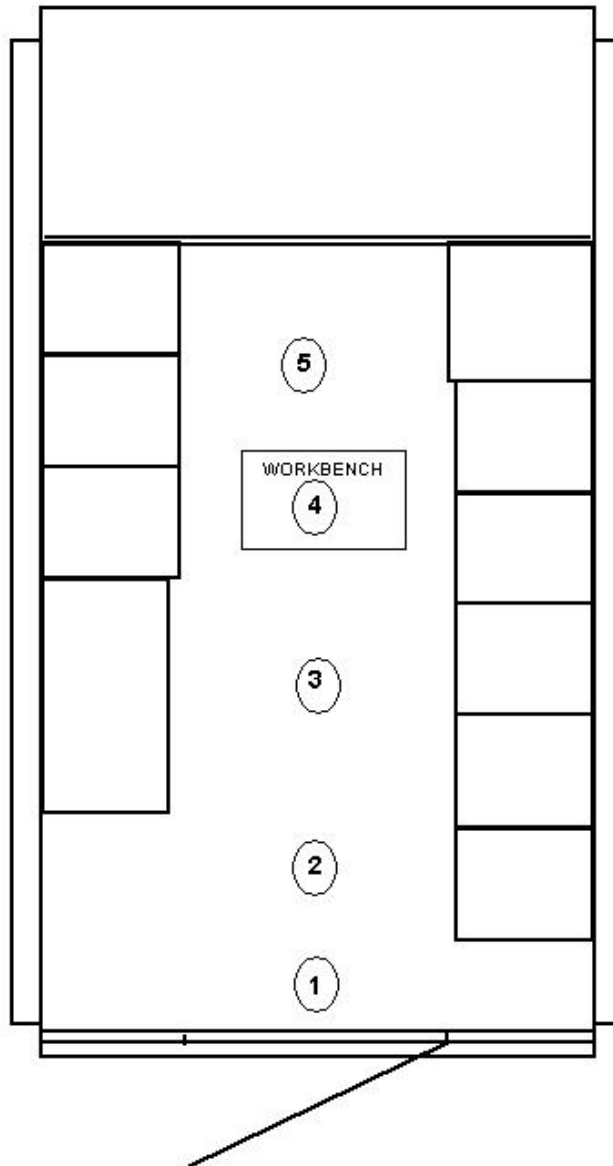

TM 9-4910-783-13&P

SATS BASE TOOL INVENTORY LIST

0058 00

NOMENCLATURE	QTY	RACK	SHELF	LOCATION	INVENTORY AMOUNT
PUMP, LUBRICANT	1	B	1	2	
WISE, MACHINIST'S, 4 INCH	1	B	2	1	
FILTER, SOLVENT, FOR WASHER (PROTOTYPE)	1	B	2	2	
DEGREASER, PORTABLE	1	B	2	3	
JACK, BOTTLE, HYDRAULIC, HAND, 12 TON	1	B	3	1	
GRINDING MACHINE, UTILITY	1	B	3	2	

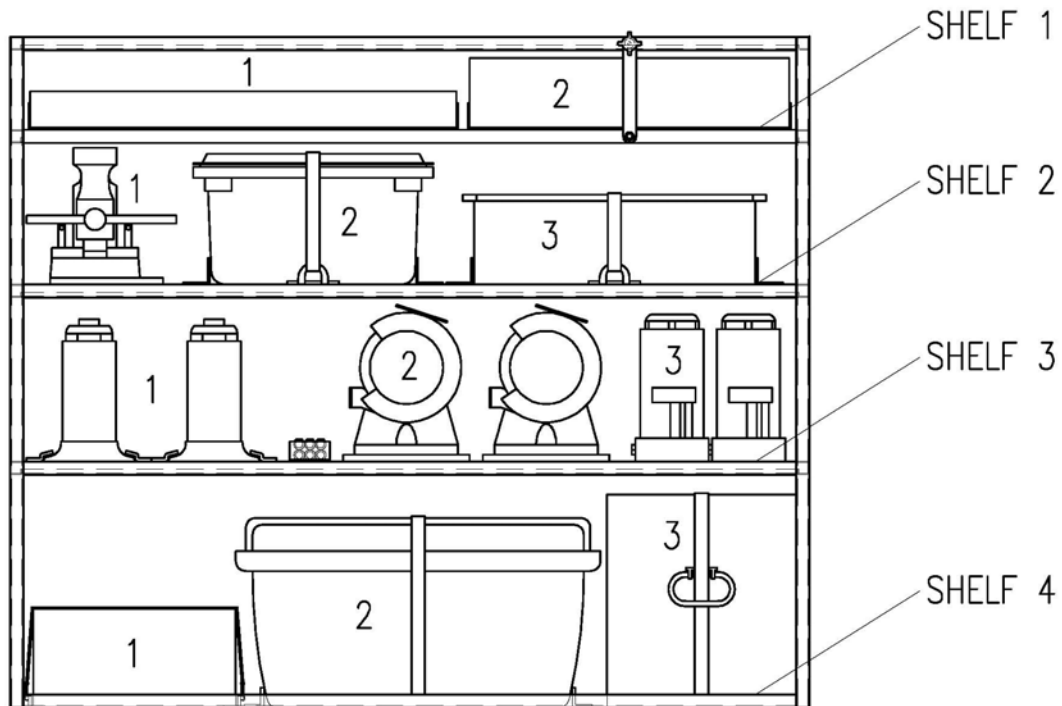

FRONT VIEW OF B

TM 9-4910-783-13&P

SATS BASE TOOL INVENTORY LIST

0058 00

NOMENCLATURE	INVENTORY				
	QTY	RACK	DRAWER	LOCATION	AMOUNT
PNEUMATIC BAG KIT, LIFTING	1	D		8	
CABLE ASSEMBLY, POWER	2	G	1	1,2	

G, 1

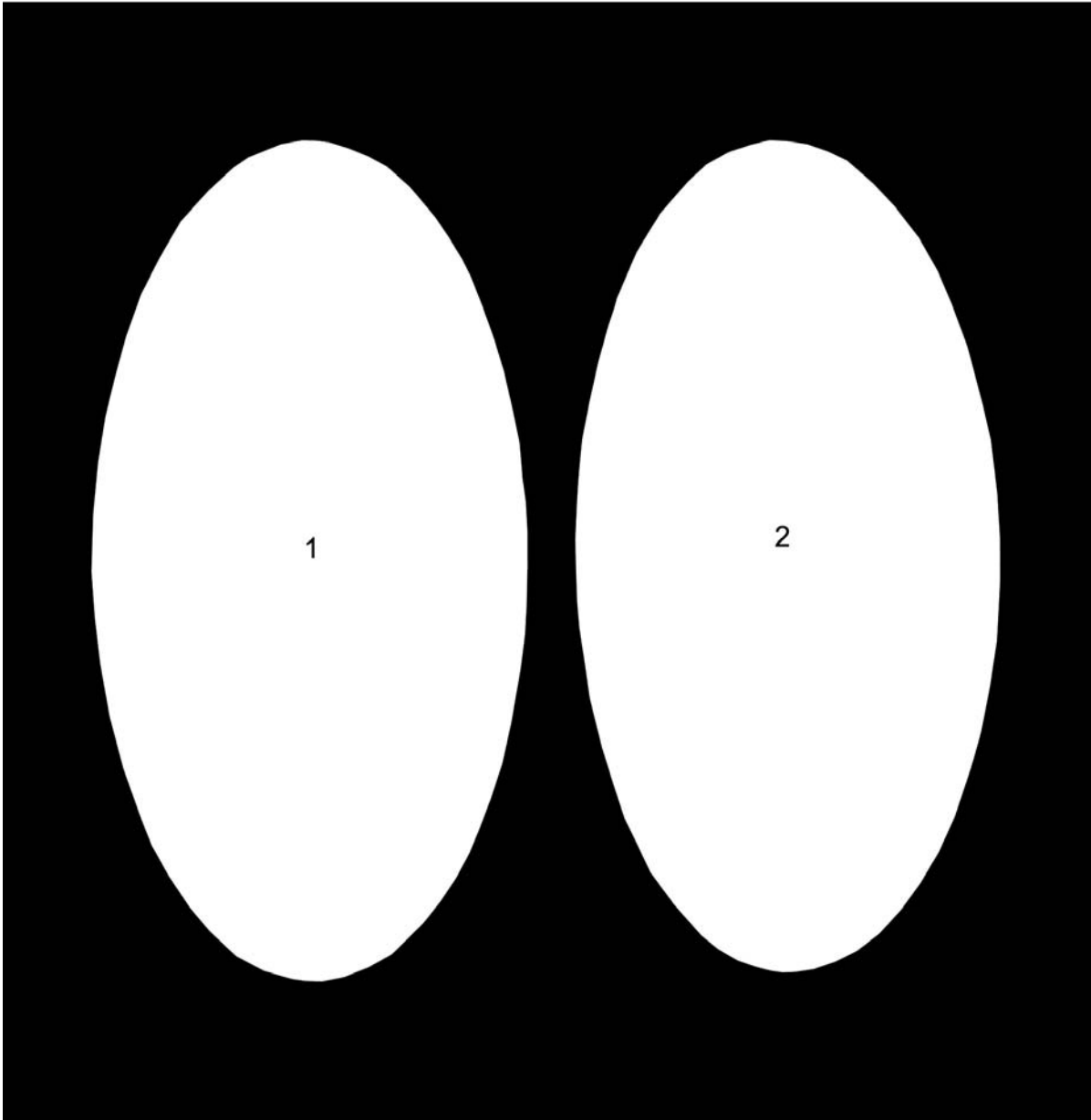

TM 9-4910-783-13&P

SATS BASE TOOL INVENTORY LIST

0058 00

INVENTORY

NOMENCLATURE	QTY	RACK	DRAWER	LOCATION	AMOUNT
CABLE KIT, SPECIAL POWER	1	G	2	1	

G, 2

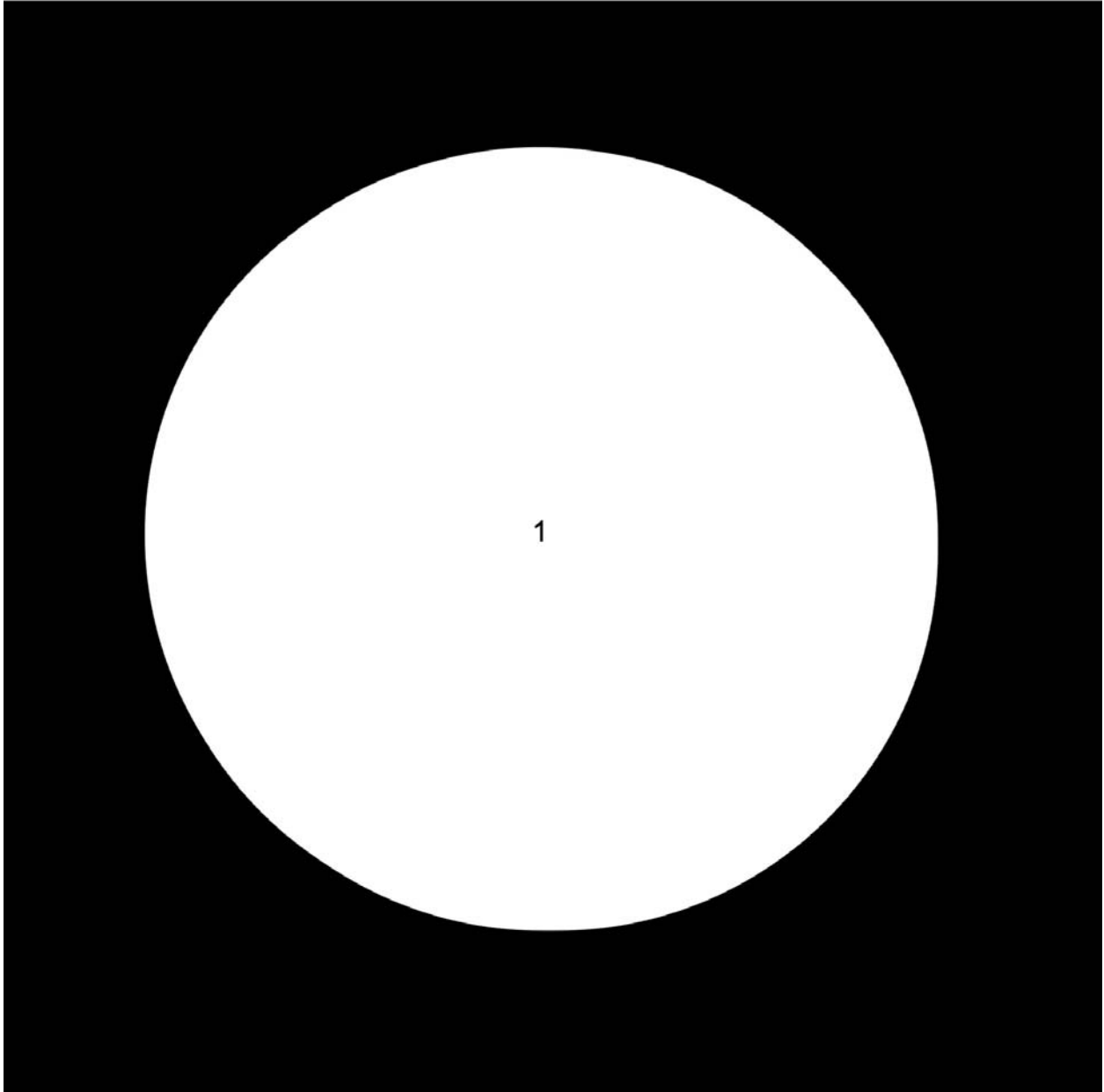

TM 9-4910-783-13&P

SATS BASE TOOL INVENTORY LIST

0058 00

INVENTORY

NOMENCLATURE	QTY	RACK	DRAWER	LOCATION	AMOUNT
BRUSH, WIRE, SCRATCH	1	H	1	1	
ANALYZER, BATTERY AND CHARGING SYSTEM	1	H	1	2	
BATTERY KIT, SERVICE	1	H	1	3	
BRUSH, WIRE, ROTARY, END ATTACHMENT, CIRCULAR, SIDE FLARE	1	H	1	4	
BRUSH, WIRE, ROTARY, END ATTACHMENT, SOLID WIRE FILLED	1	H	1	5	
BRUSH, FILE CLEANER	1	H	1	6	
BATTERY FILLER, GRAVITY	1	H	1	7	
BATTERY FILLER, SYRINGE	2	H	1	8, 9	

H, 1

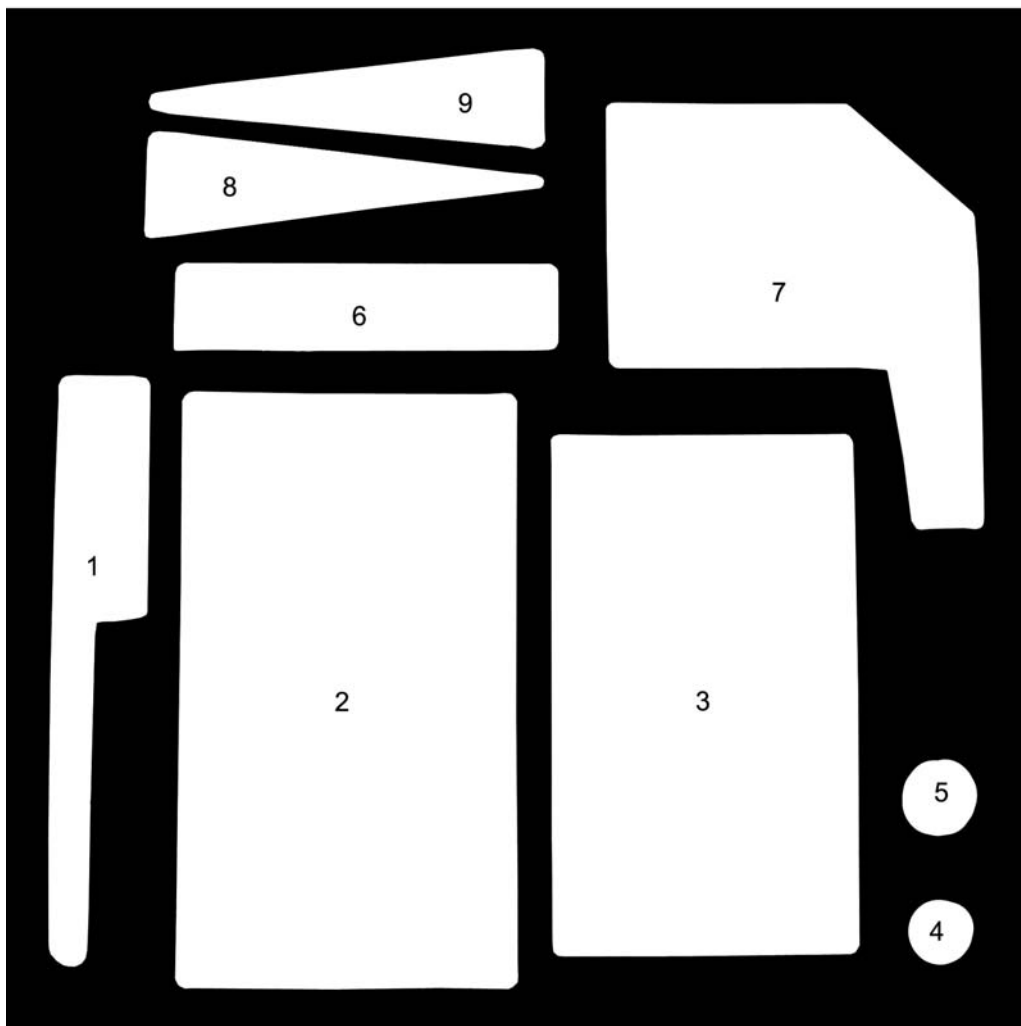

TM 9-4910-783-13&P

H, 2

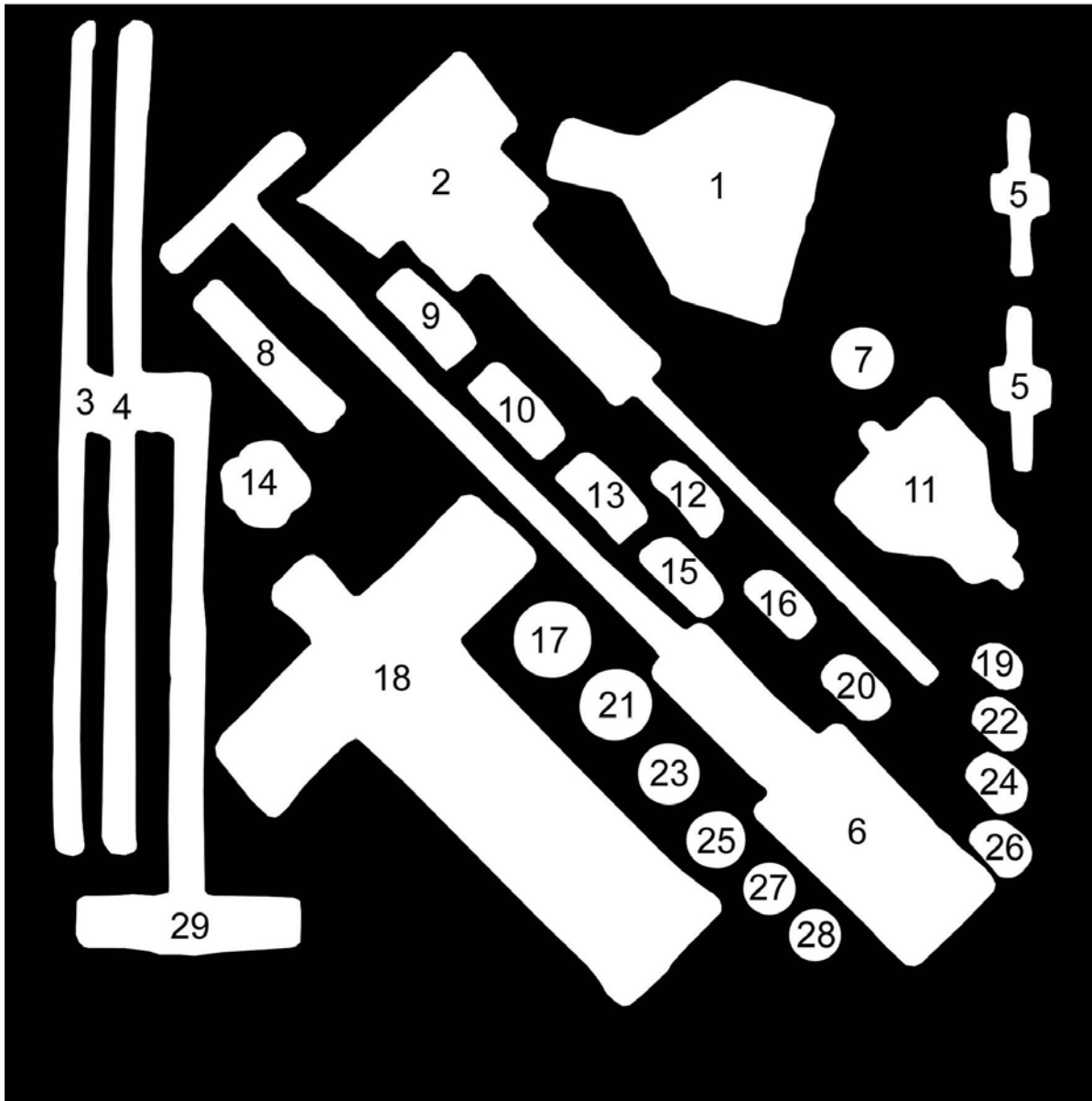

TM 9-4910-783-13&P

SATS BASE TOOL INVENTORY LIST

0058 00

NOMENCLATURE	QTY	RACK	DRAWER	LOCATION	AMOUNT
FLANGE-TYPE PULLER	1	H	2	1	
PILOT BEARING PULLER	1	H	2	2	
EXTENSION ROD	1	H	2	3	
EXTENSION ROD	1	H	2	4	
BOLTS – TWO LOCATIONS NUMBERED AS 5	1	H	2	5	
SLIDE HAMMER PULLER	1	H	2	6	
BOLTS FOR MECHANICAL PULLER SET	1	H	2	7	
BOLTS FOR MECHANICAL PULLER SET	1	H	2	8	
STEP PLATE ADAPTER, 2-1/2"	1	H	2	9	
STEP PLATE ADAPTER, 2-3/8"	1	H	2	10	
STEERING WHEEL PULLER	1	H	2	11	
STEP PLATE ADAPTER, 1-7/8"	1	H	2	12	
STEP PLATE ADAPTER, 2-1/8"	1	H	2	13	
FEMALE THREADED ADAPTER, 1/2"	1	H	2	14	
FEMALE THREADED ADAPTER, 2"	1	H	2	15	
STEP PLATE ADAPTER, 1-3/4"	1	H	2	16	
FEMALE THREADED ADAPTER, 1-1/4"	1	H	2	17	
PUSH PULLER W/ 6-3/4" LEGS	1	H	2	18	
STEP PLATE ADAPTER, 1"	1	H	2	19	
STEP PLATE ADAPTER, 1-5/8"	1	H	2	20	
FEMALE THREADED ADAPTER, 1-1/8"	1	H	2	21	
STEP PLATE ADAPTER, 1-1/8"	1	H	2	22	
FEMALE THREADED ADAPTER, 5/8"	1	H	2	23	
STEP PLATE ADAPTER, 1-1/4"	1	H	2	24	
FEMALE THREADED ADAPTER, 7/8"	1	H	2	25	
STEP PLATE ADAPTER, 1-3/8"	1	H	2	26	
FEMALE THREADED ADAPTER, 3/4"	1	H	2	27	
FEMALE THREADED ADAPTER, 5/8"	1	H	2	28	
GEAR AND PULLEY PULLERS, 13"	1	H	2	29	
PULLER SET, MECHANICAL	1	H	2	1 thru 29	

TM 9-4910-783-13&P

SATS BASE TOOL INVENTORY LIST

0058 00

INVENTORY

NOMENCLATURE	QTY	RACK	DRAWER	LOCATION	AMOUNT
PULLER SET, MECHANICAL	1	H	3	1 thru 9	
PULLER, PITTMAN ARM	1	H	3	1	
BEARING CUP PULLER ATTACHMENT	1	H	3	2	
BEARING SPLITTER, 4-5/8" MAX	1	H	3	3	
2-JAW PULLER, 13 TON, 11"	1	H	3	4	
BEARING SPLITTER 15/16" MAX	1	H	3	5	
BEARING SPLITTER, 2" MAX	1	H	3	6	
2-JAW PULLER, 2 TON, 3-1/4"	1	H	3	7	
2-JAW PULLER, 7 TON, 5"	1	H	3	8	
2-JAW PULLER, 5 TON, 3-1/4"	1	H	3	9	

H, 3

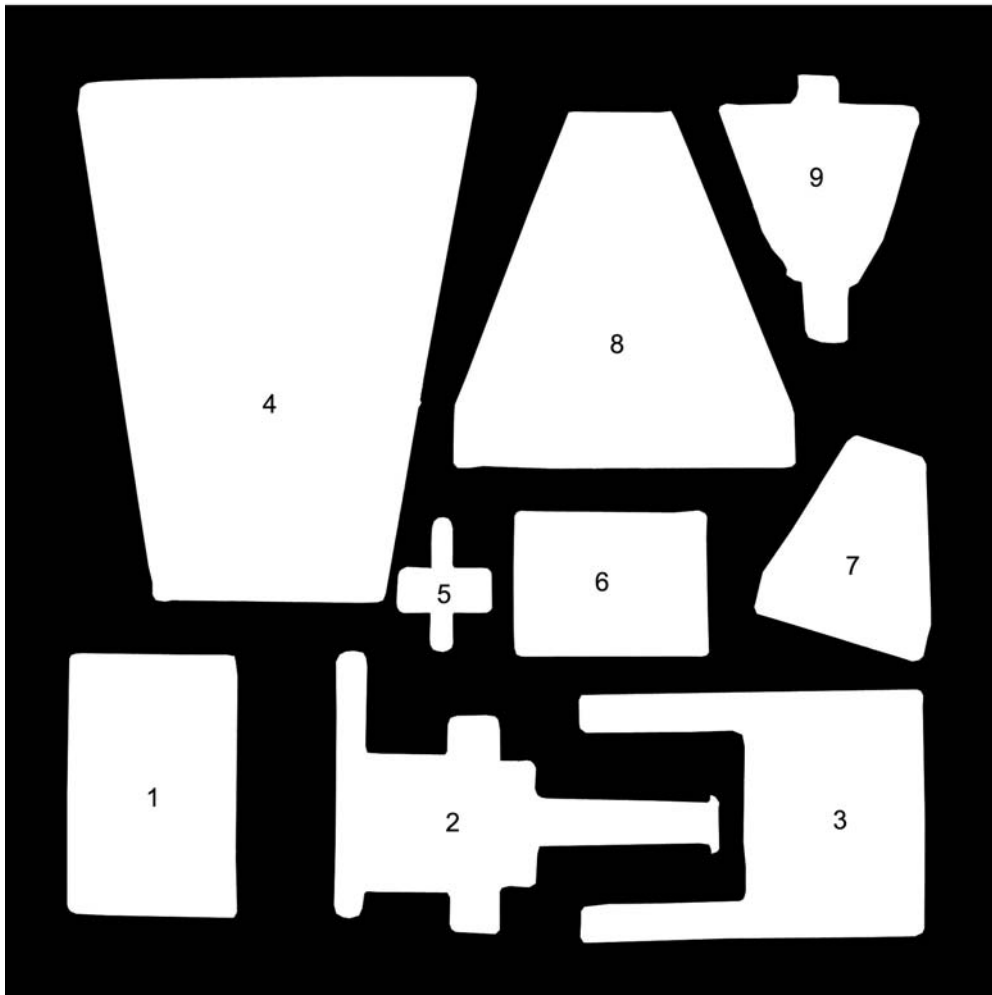

TM 9-4910-783-13&P

SATS BASE TOOL INVENTORY LIST

0058 00

INVENTORY

NOMENCLATURE	QTY	RACK	DRAWER	LOCATION	AMOUNT
PULLER, MECHANICAL, PITTMAN ARM	1	H	4	1	
PULLER, MECHANICAL, STEERING WHEEL	1	H	4	2	
BRAZING AND SOLDERING SET	1	H	4	3	
ADAPTER KIT, GREASE GUN COUPLING	1	H	4	4	

H, 4

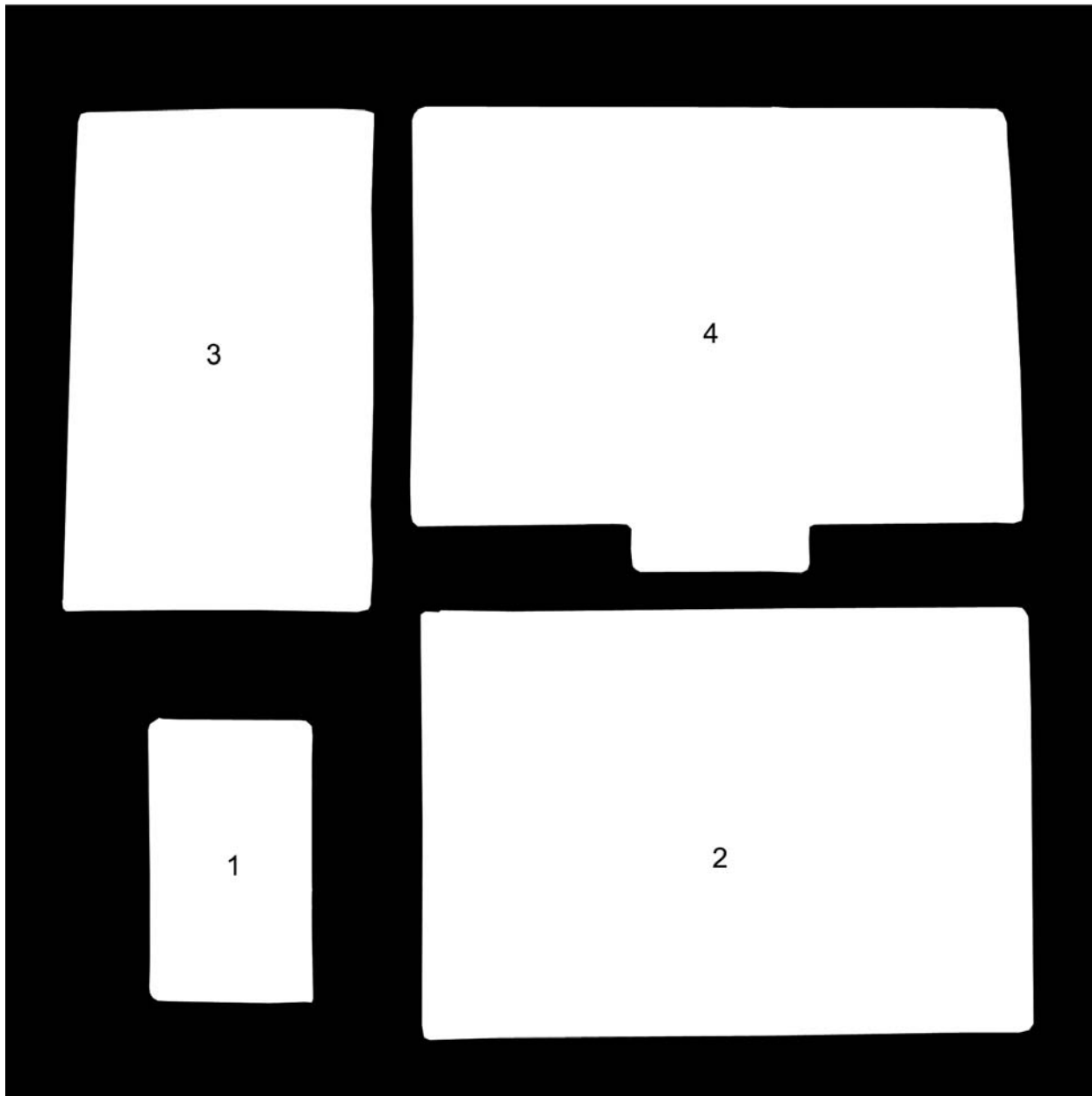

TM 9-4910-783-13&P

SATS BASE TOOL INVENTORY LIST

0058 00

INVENTORY

NOMENCLATURE	QTY	RACK	DRAWER	LOCATION	AMOUNT
WRENCH, OIL FILTER, STRAP	1	H	5	2	
TEST KIT, RADIATOR PRESSURE	1	H	5	3	
WRENCH, OIL FILTER, STRAP	1	H	5	4	
PLIERS, BRAKE REPAIR, HEAVY	1	H	5	5	
PLIERS, BRAKE REPAIR, LIGHT	1	H	5	6	
ADJUSTING TOOL, BRAKE SHOE	1	H	5	7	
WRENCH, OIL FILTER	1	H	5	8	
FILLER AND BLEEDER KIT, BRAKE SYSTEM	1	H	5	10	
TESTER, ANTIFREEZE SOLUTION	1	H	5	1,9	

H, 5

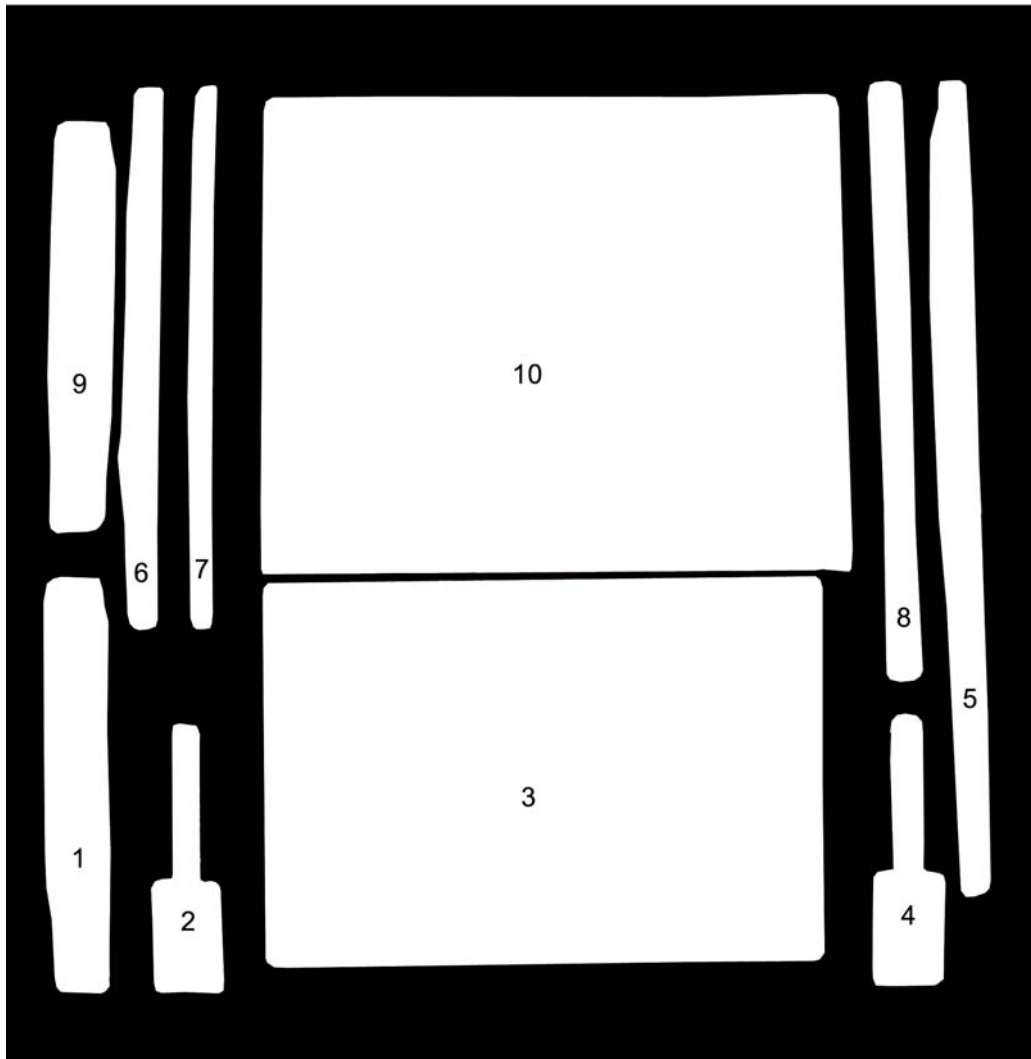

TM 9-4910-783-13&P

SATS BASE TOOL INVENTORY LIST

0058 00

NOMENCLATURE	INVENTORY				
	QTY	RACK	DRAWER	LOCATION	AMOUNT
GREASE GUN, PNEUMATIC, HOSE	1	H	6	2	
GREASE GUN, PNEUMATIC	1	H	6	3	
GUN, FLUID, DIRECT DELIVERY	2	H	6	1, 4	

H, 6

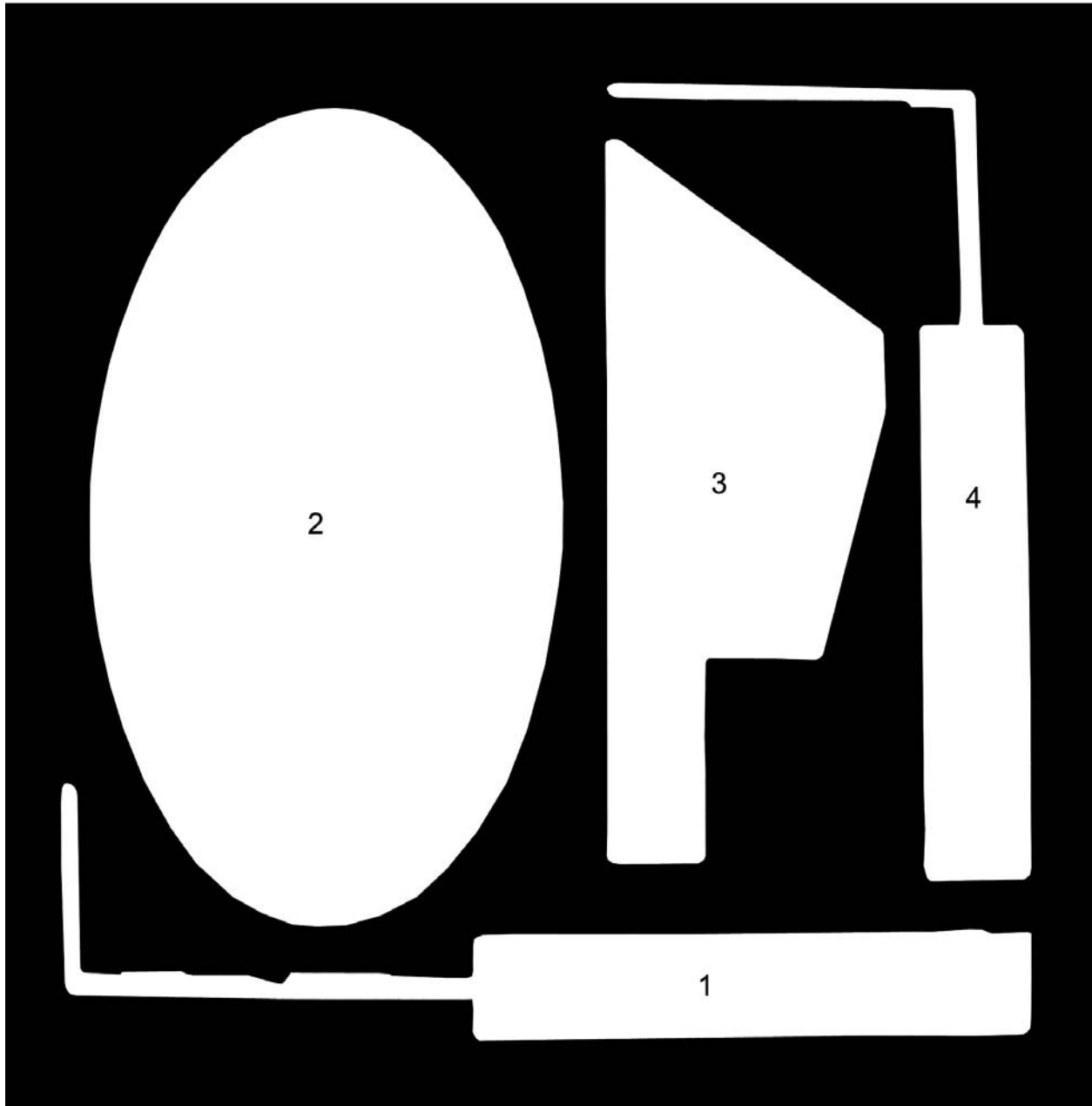

TM 9-4910-783-13&P

SATS BASE TOOL INVENTORY LIST

0058 00

NOMENCLATURE	INVENTORY				
	QTY	RACK	DRAWER	LOCATION	AMOUNT
OILER, HAND	2	H	7	1,5	
LUBRICATING GUN, HAND	3	H	7	2,3,4	

H, 7

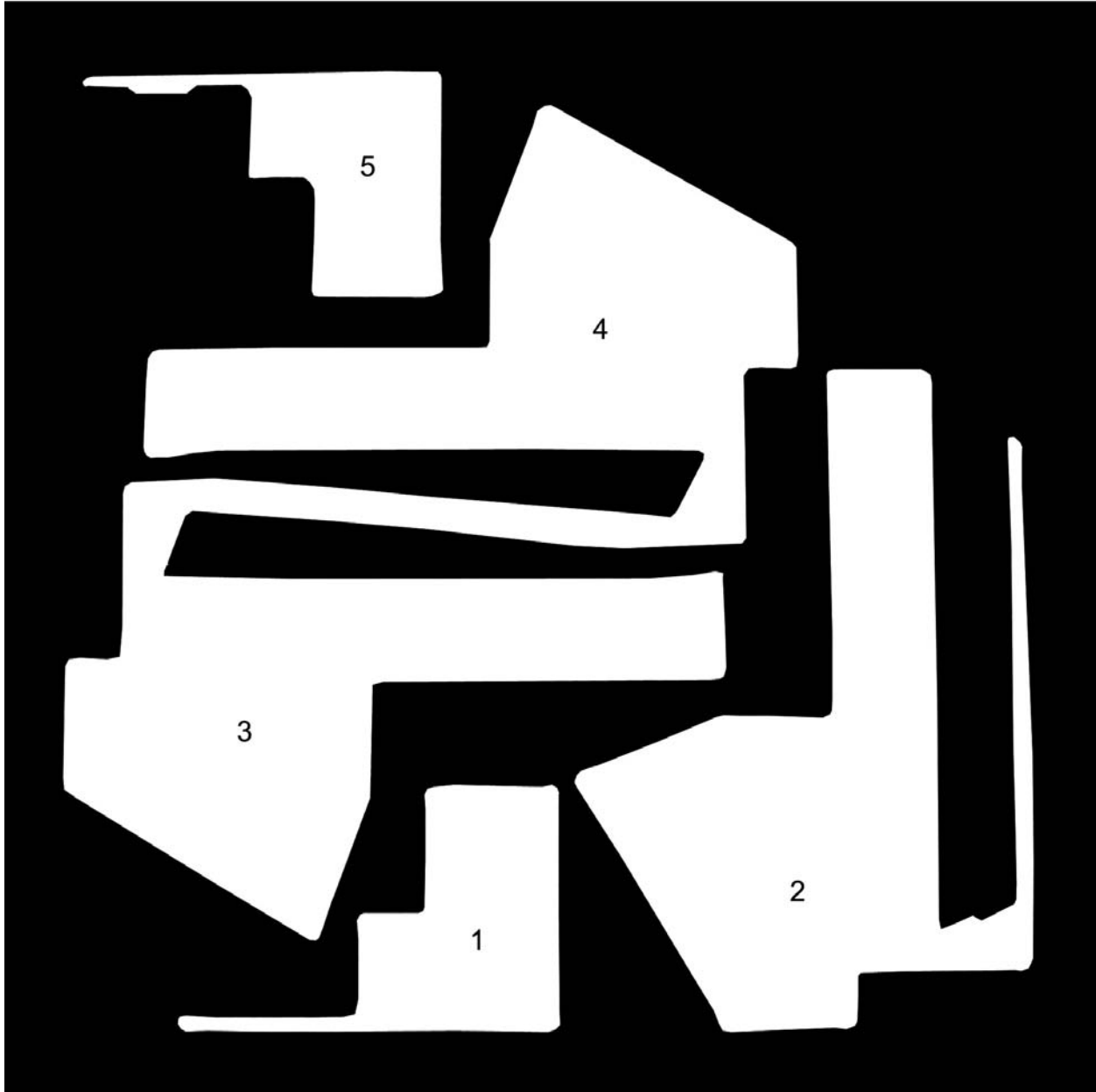

TM 9-4910-783-13&P

SATS BASE TOOL INVENTORY LIST

0058 00

NOMENCLATURE	INVENTORY				AMOUNT
	QTY	RACK	DRAWER	LOCATION	
LUBRICATING GUN, BATTERY, RECHARGEABLE, 12V	1	H	8	1	
CHARGER, 12V	1	H	8	2	
BATTERY, 12V	1	H	8	3	

H, 8

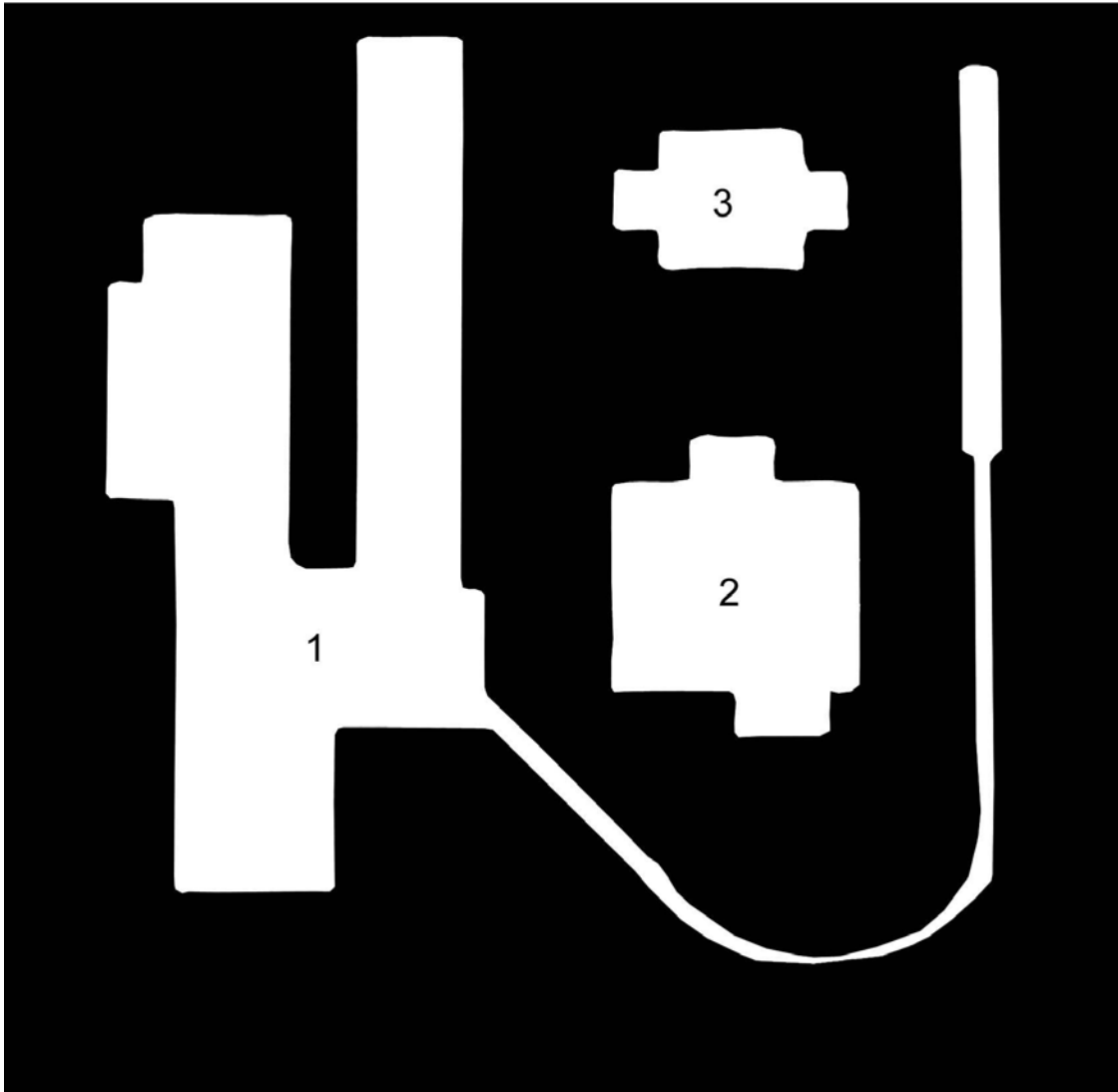

TM 9-4910-783-13&P

SATS BASE TOOL INVENTORY LIST

0058 00

H,9

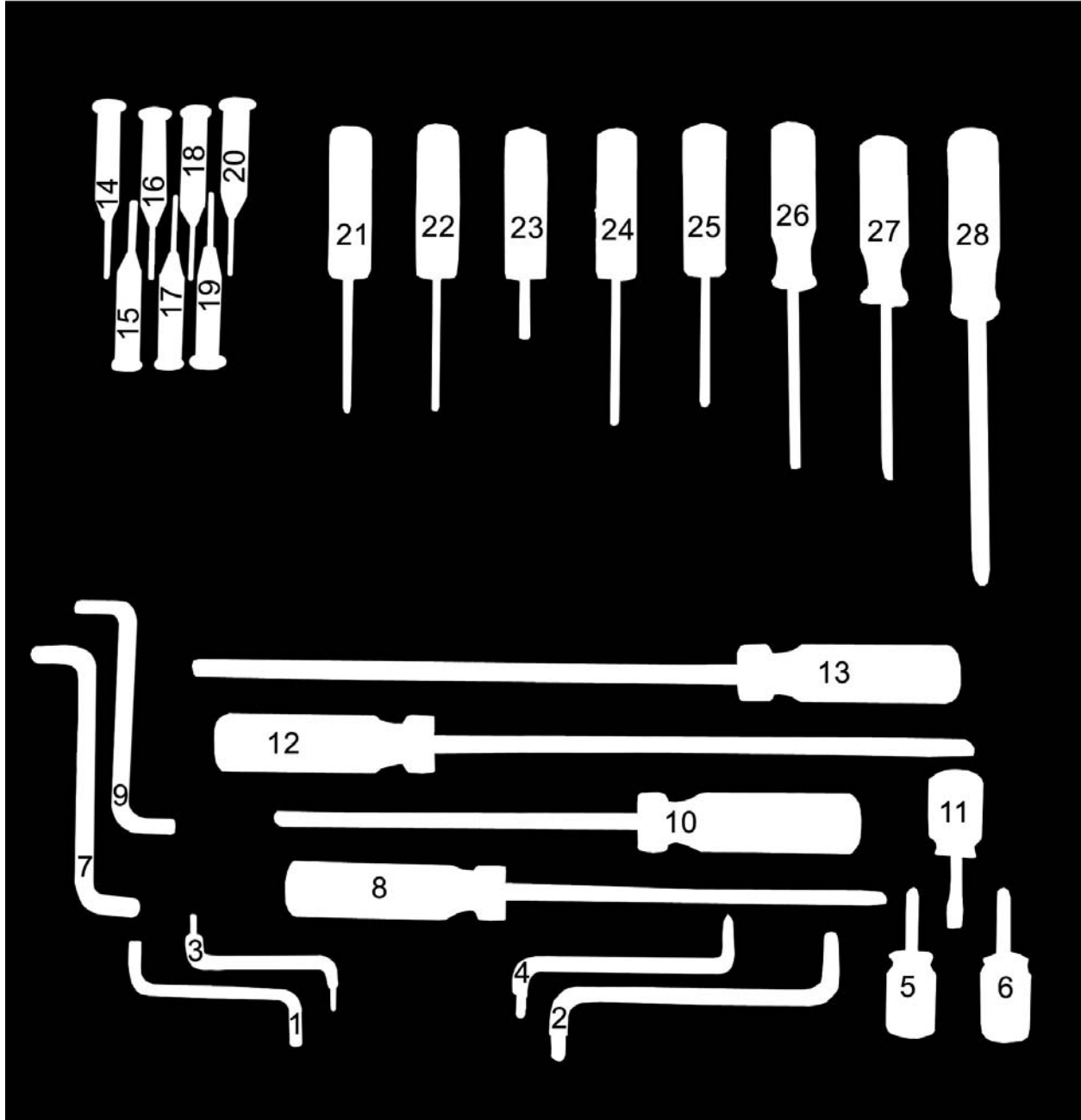

TM 9-4910-783-13&P

SATS BASE TOOL INVENTORY LIST

0058 00

NOMENCLATURE	QTY	RACK	DRAWER	LOCATION	INVENTORY AMOUNT
SCREWDRIVER, OFFSET, FLAT TIP, 5/32" TIP, 3" LONG	1	H	9	1	
SCREWDRIVER, OFFSET, FLAT TIP, 3/8" TIP, 6" LONG	1	H	9	2	
SCREWDRIVER, OFFSET, FLAT TIP, 5/16" TIP, 5" LONG	1	H	9	3	
SCREWDRIVER, OFFSET, FLAT TIP, 1/4" TIP, 4" LONG	1	H	9	4	
SCREWDRIVER, STUBBY, CROSS TIP, #2, 3.5" LONG	1	H	9	5	
SCREWDRIVER, STUBBY, FLAT TIP, 1/4" TIP, 3.5" LONG	1	H	9	6	
SCREWDRIVER, OFFSET, CROSS TIP, #3 & #4 TIP, 6.5" LONG	1	H	9	7	
SCREWDRIVER, ROUND SHANK, CROSS TIP, #4 TIP, 13.5" LONG	1	H	9	8	
SCREWDRIVER, OFFSET, CROSS TIP, #1 & #2 TIP, 4.5" LONG	1	H	9	9	
SCREWDRIVER, ROUND SHANK, CROSS TIP, #4 TIP, 13.5" LONG	1	H	9	10	
SCREWDRIVER, STUBBY, FLAT TIP, 3/16" TIP, 3" LONG	1	H	9	11	
SCREWDRIVER, SQUARE SHANK, FLAT TIP, 3/8" TIP, 17.5" LONG	1	H	9	12	
SCREWDRIVER, SQUARE SHANK, FLAT TIP, 3/8" TIP, 17.5" LONG	1	H	9	13	
SCREWDRIVER, JEWELER, 1.5MM	1	H	9	14	
SCREWDRIVER, JEWELER, 2MM	1	H	9	15	
SCREWDRIVER, JEWELER, 2.5MM	1	H	9	16	
SCREWDRIVER, JEWELER, 3MM	1	H	9	17	
SCREWDRIVER, JEWELER, #00	1	H	9	18	
SCREWDRIVER, JEWELER, #0	1	H	9	19	
SCREWDRIVER, JEWELER, #1	1	H	9	20	
SCREWDRIVER, TORX, T10, 3" LONG	1	H	9	21	
SCREWDRIVER, TORX, T15, 3" LONG	1	H	9	22	
SCREWDRIVER, TORX, T15, 1.25" LONG	1	H	9	23	
SCREWDRIVER, TORX, T20, 3" LONG	1	H	9	24	
SCREWDRIVER, TORX, T25, 3" LONG	1	H	9	25	
SCREWDRIVER, TORX, T27, 4" LONG	1	H	9	26	
SCREWDRIVER, TORX, T30, 4" LONG	1	H	9	27	
SCREWDRIVER, TORX, T40, 6" LONG	1	H	9	28	

TM 9-4910-783-13&P

SATS BASE TOOL INVENTORY LIST

0058 00

INVENTORY

NOMENCLATURE	QTY	RACK	DRAWER	LOCATION	AMOUNT
LIGHT, BATTERY 18V, RECHARGEABLE, CASE	1	H	10	1	
LIGHT, EXTENSION	1	H	10	2	
LAMP, FLUORESCENT (REPLACEMENT BULK) (PROTOTYPE)	1	H	10	5	
LIGHT, EXTENSION, LED (PROTOTYPE)	2	H	10	3,4	

H, 10

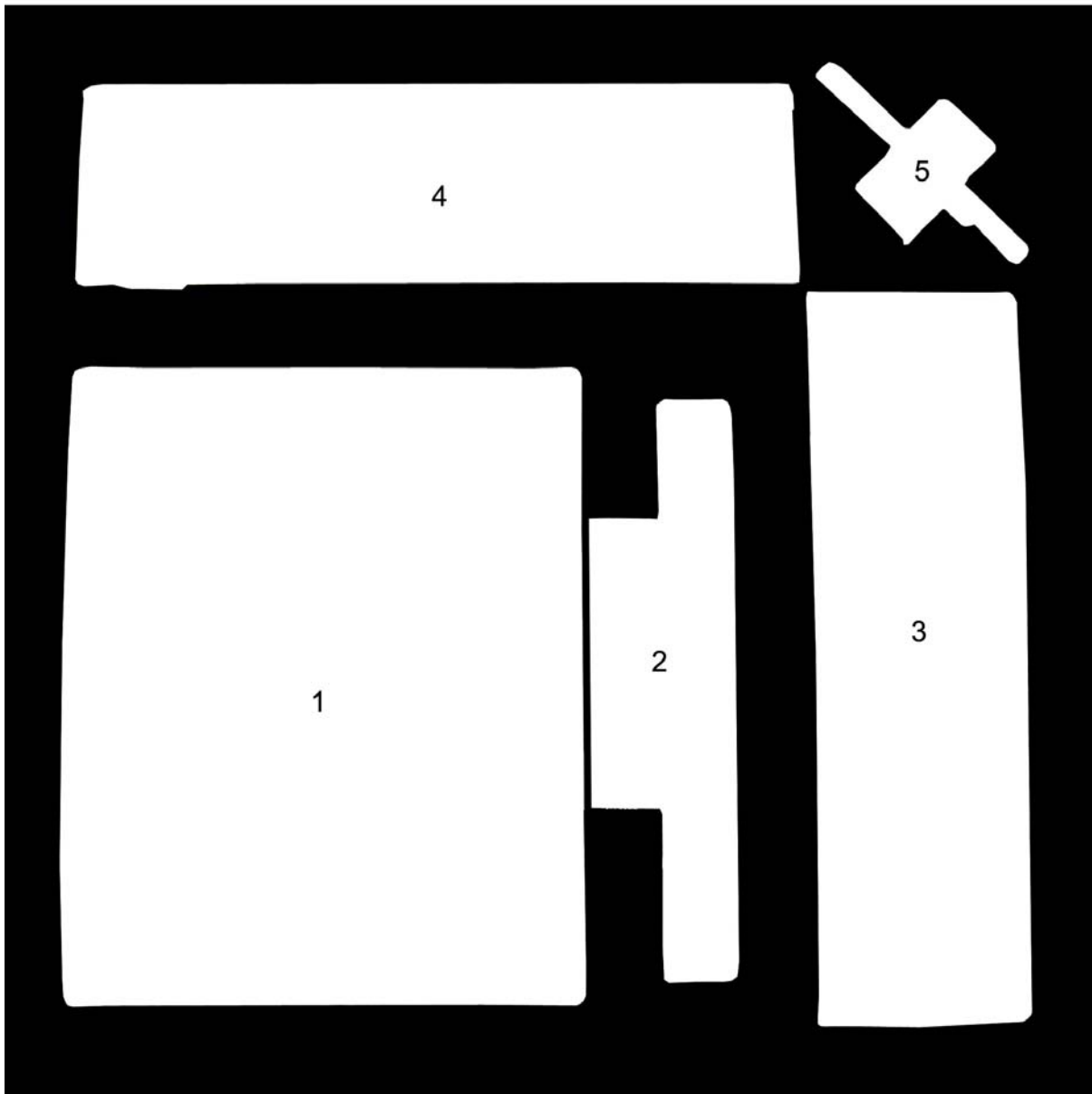

TM 9-4910-783-13&P

SATS BASE TOOL INVENTORY LIST

0058 00

INVENTORY

NOMENCLATURE	QTY	RACK	DRAWER	LOCATION	AMOUNT
WRENCH, IMPACT, PNEUMATIC, 3/4" SQUARE DRIVE, 1200 FT-LB	1	J	1	1	
CABLE ASSEMBLY, POWER	1	J	1	2	
WRENCH, IMPACT, ELECTRIC, 3/4" SQUARE DRIVE HANDLE	1	J	1	3	

J, 1

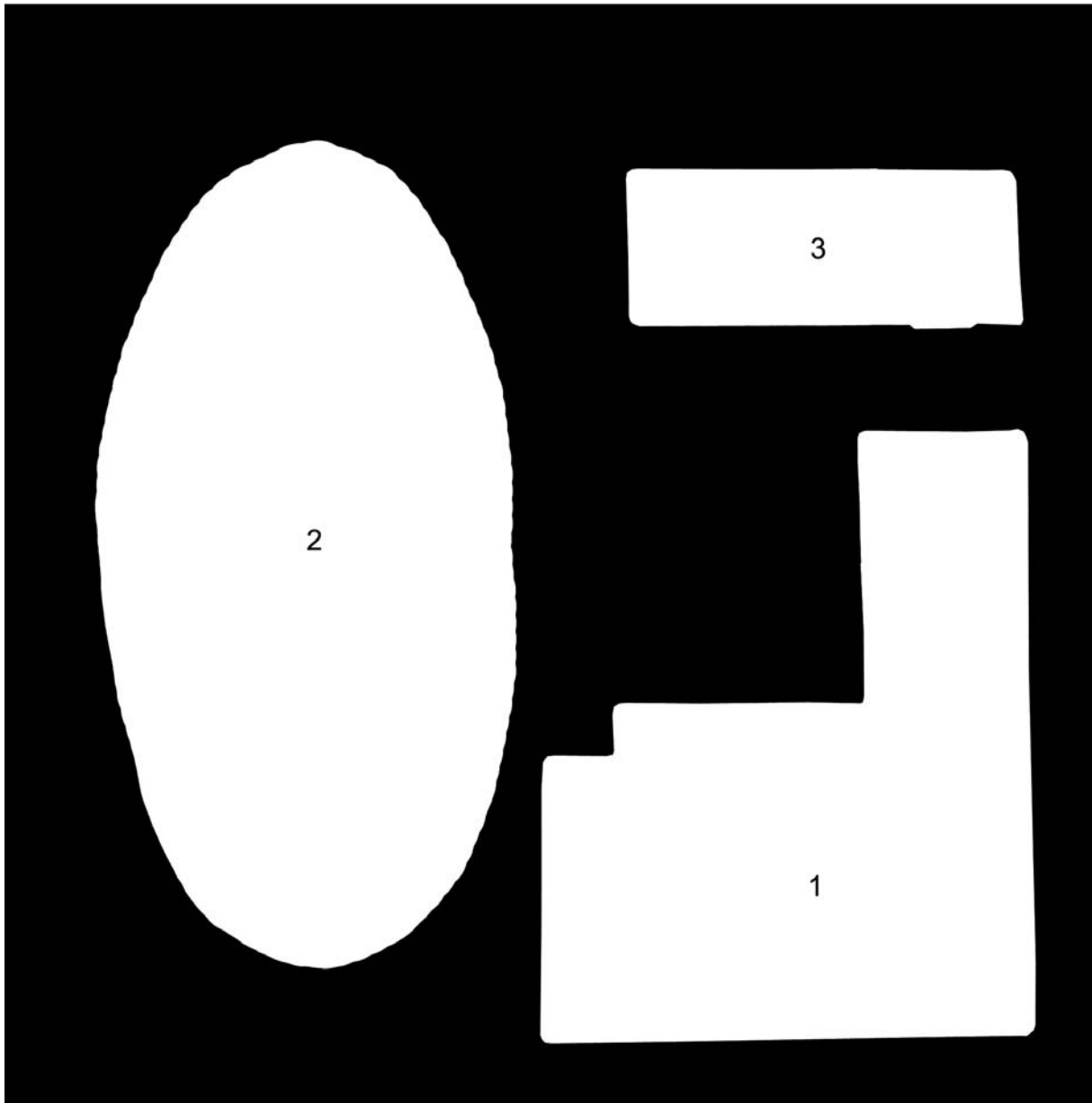

TM 9-4910-783-13&P

J, 2

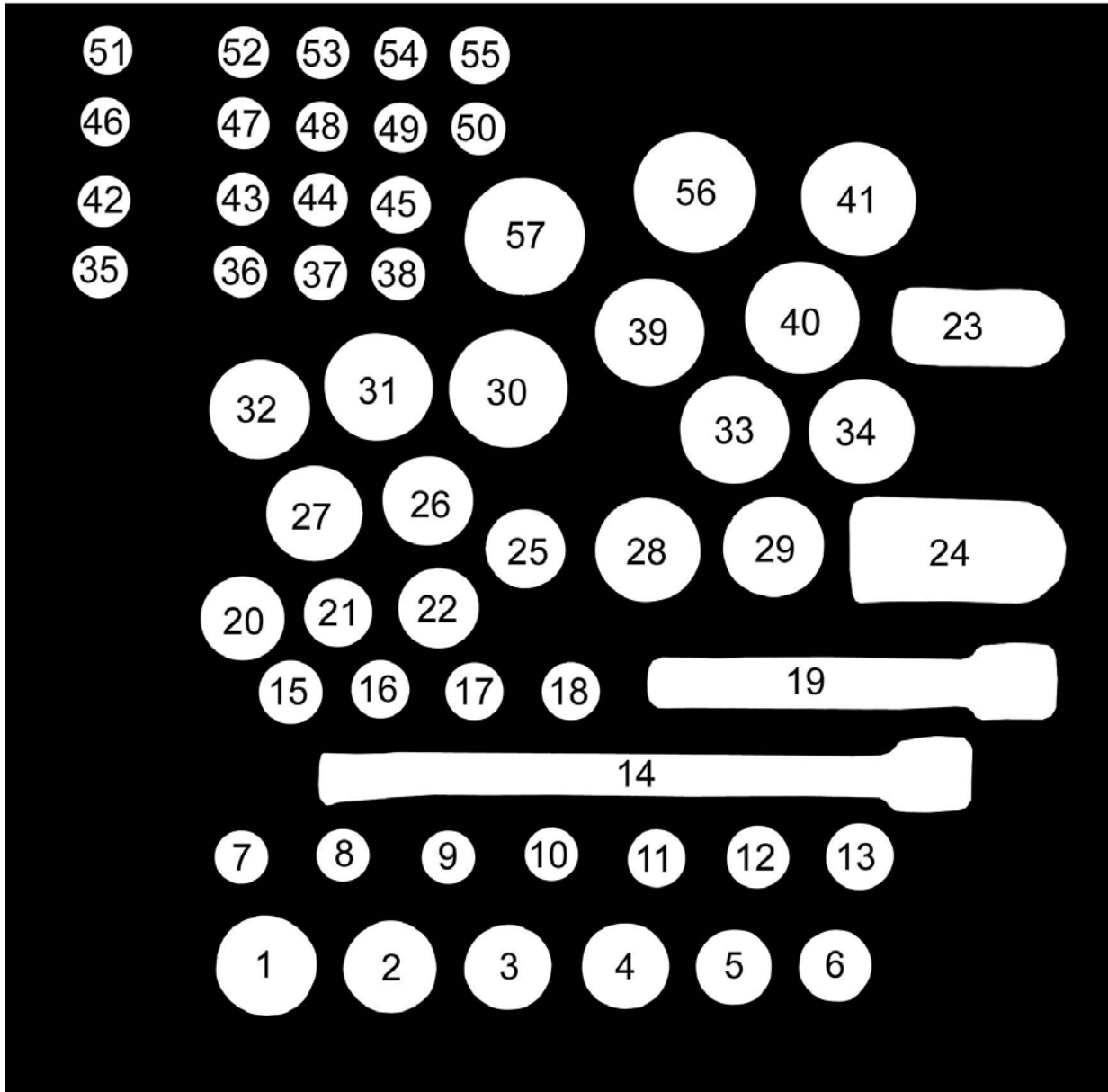

TM 9-4910-783-13&P

SATS BASE TOOL INVENTORY LIST

0058 00

NOMENCLATURE	QTY	RACK	DRAWER	LOCATION	AMOUNT
SOCKET, IMPACT WRENCH, 3/4" DR, 6 PT, 1-1/2"	1	J	2	1	
SOCKET, IMPACT WRENCH, 3/4" DR, 6 PT, 1-7/16"	1	J	2	2	
SOCKET, IMPACT WRENCH, 3/4" DR, 6 PT, 1-5/16"	1	J	2	3	
SOCKET, IMPACT WRENCH, 3/4" DR, 6 PT, 1-1/4"	1	J	2	4	
SOCKET, IMPACT WRENCH, 3/4" DR, 6 PT, 1-1/8"	1	J	2	5	
SOCKET, IMPACT WRENCH, 3/4" DR, 6 PT, 1-1/16"	1	J	2	6	
SOCKET, IMPACT WRENCH, 3/4" DR, 6 PT, 5/8"	1	J	2	7	
SOCKET, IMPACT WRENCH, 3/4" DR, 6 PT, 5/16"	1	J	2	8	
SOCKET, IMPACT WRENCH, 3/4" DR, 6 PT, 3/4 "	1	J	2	9	
SOCKET, IMPACT WRENCH, 3/4" DR, 6 PT, 11/16"	1	J	2	10	
SOCKET, IMPACT WRENCH, 3/4" DR, 6 PT, 13/16"	1	J	2	11	
SOCKET, IMPACT WRENCH, 3/4" DR, 6 PT, 7/8"	1	J	2	12	
SOCKET, IMPACT WRENCH, 3/4" DR, 6 PT, 1"	1	J	2	13	
BAR, EXTENSION, 3/4" DR, 12.5"	1	J	2	14	
SOCKET, IMPACT SOCKET, 3/4" DR, 6 PT, 22MM	1	J	2	15	
SOCKET, IMPACT SOCKET, 3/4" DR, 6 PT, 20MM	1	J	2	16	
SOCKET, IMPACT SOCKET, 3/4" DR, 6 PT, 19MM	1	J	2	17	
SOCKET, IMPACT SOCKET, 3/4" DR, 6 PT, 17MM	1	J	2	18	
BAR, EXTENSION, 3/4" DR, 6.5"	1	J	2	19	
SOCKET, IMPACT SOCKET, 3/4" DR, 6 PT, 27MM	1	J	2	20	
SOCKET, IMPACT SOCKET, 3/4" DR, 6 PT, 24MM	1	J	2	21	
SOCKET, IMPACT SOCKET, 3/4" DR, 6 PT, 30MM	1	J	2	22	
SOCKET, IMPACT SOCKET, 3/4" DR, DEEP, 4 PT, 13/16"	1	J	2	23	
SOCKET, IMPACT SOCKET, 3/4" DR, 6 PT, DEEP, BUDD WHEEL, DOUBLE OPENING, 1-1/2" & 13/16"	1	J	2	24	
SOCKET, IMPACT SOCKET, 3/4" DR, 6 PT, 31MM	1	J	2	25	
SOCKET, IMPACT SOCKET, 3/4" DR, 6 PT, 34MM	1	J	2	26	
SOCKET, IMPACT SOCKET, 3/4" DR, 6 PT, 36MM	1	J	2	27	
SOCKET, IMPACT WRENCH, 3/4" DR, 6 PT, 1-1/2"	1	J	2	28	
SOCKET, IMPACT SOCKET, 3/4" DR REGULAR, 6 PT, 1-9/16"	1	J	2	29	
SOCKET, IMPACT SOCKET, 3/4" DR, 6 PT, 46MM	1	J	2	30	
SOCKET, IMPACT SOCKET, 3/4" DR, 6 PT, 40MM	1	J	2	31	
SOCKET, IMPACT SOCKET, 3/4" DR, 6 PT, 38MM	1	J	2	32	
SOCKET, IMPACT SOCKET, 3/4" DR REGULAR, 6 PT, 1-11/16"	1	J	2	33	
SOCKET, IMPACT SOCKET, 3/4" DR REGULAR, 6 PT, 1-5/8"	1	J	2	34	
SOCKET, IMPACT SOCKET, UNIVERSAL, 1/2" DR, 6 PT, 11/16"	1	J	2	35	
SOCKET, IMPACT SOCKET, UNIVERSAL, 1/2" DR, 6 PT, 5/8"	1	J	2	36	

TM 9-4910-783-13&P

SATS BASE TOOL INVENTORY LIST

0058 00

INVENTORY

NOMENCLATURE	QTY	RACK	DRAWER	LOCATION	AMOUNT
SOCKET, IMPACT SOCKET, UNIVERSAL, 1/2"DR, 6 PT, 9/16"	1	J	2	37	
SOCKET, IMPACT SOCKET, UNIVERSAL, 1/2"DR, 6 PT, 1/2"	1	J	2	38	
SOCKET, IMPACT SOCKET, 3/4" DR REGULAR, 6 PT, 1-3/4"	1	J	2	39	
SOCKET, IMPACT SOCKET, 3/4" DR REGULAR, 6 PT, 1-13/16"	1	J	2	40	
SOCKET, IMPACT SOCKET, 3/4" DR REGULAR, 6 PT, 2"	1	J	2	41	
SOCKET, IMPACT SOCKET, UNIVERSAL, 1/2" DR, 6 PT, 3/4"	1	J	2	42	
SOCKET, IMPACT SOCKET, UNIVERSAL, 1/2" DR, 6 PT, 13/16"	1	J	2	43	
SOCKET, IMPACT SOCKET, UNIVERSAL, 1/2" DR, 6 PT, 7/8"	1	J	2	44	
SOCKET, IMPACT SOCKET, UNIVERSAL, 1/2" DR, 6 PT, 15/16"	1	J	2	45	
SOCKET, IMPACT SOCKET, UNIVERSAL, 1/2" DR, 6 PT, 17MM	1	J	2	46	
SOCKET, IMPACT SOCKET, UNIVERSAL, 1/2" DR, 6 PT, 16MM	1	J	2	47	
SOCKET, IMPACT SOCKET, UNIVERSAL, 1/2" DR, 6 PT, 15MM	1	J	2	48	
SOCKET, IMPACT SOCKET, UNIVERSAL, 1/2" DR, 6 PT, 14MM	1	J	2	49	
SOCKET, IMPACT SOCKET, UNIVERSAL, 1/2" DR, 6 PT, 13MM	1	J	2	50	
SOCKET, IMPACT SOCKET, UNIVERSAL, 1/2" DR, 6 PT, 18MM	1	J	2	51	
SOCKET, IMPACT SOCKET, UNIVERSAL, 1/2" DR, 6 PT, 19MM	1	J	2	52	
SOCKET, IMPACT SOCKET, UNIVERSAL, 1/2" DR, 6 PT, 21MM	1	J	2	53	
SOCKET, IMPACT SOCKET, UNIVERSAL, 1/2" DR, 6 PT, 22MM	1	J	2	54	
SOCKET, IMPACT SOCKET, UNIVERSAL, 1/2" DR, 6 PT, 24MM	1	J	2	55	
SOCKET, IMPACT SOCKET, 3/4" DR REGULAR, 6 PT, 1-7/8"	1	J	2	56	
SOCKET, IMPACT SOCKET, 3/4" DR REGULAR, 6 PT, 1-15/16"	1	J	2	57	

TM 9-4910-783-13&P

SATS BASE TOOL INVENTORY LIST

0058 00

THIS PAGE INTENTIONALLY LEFT BLANK

TM 9-4910-783-13&P

J, 3

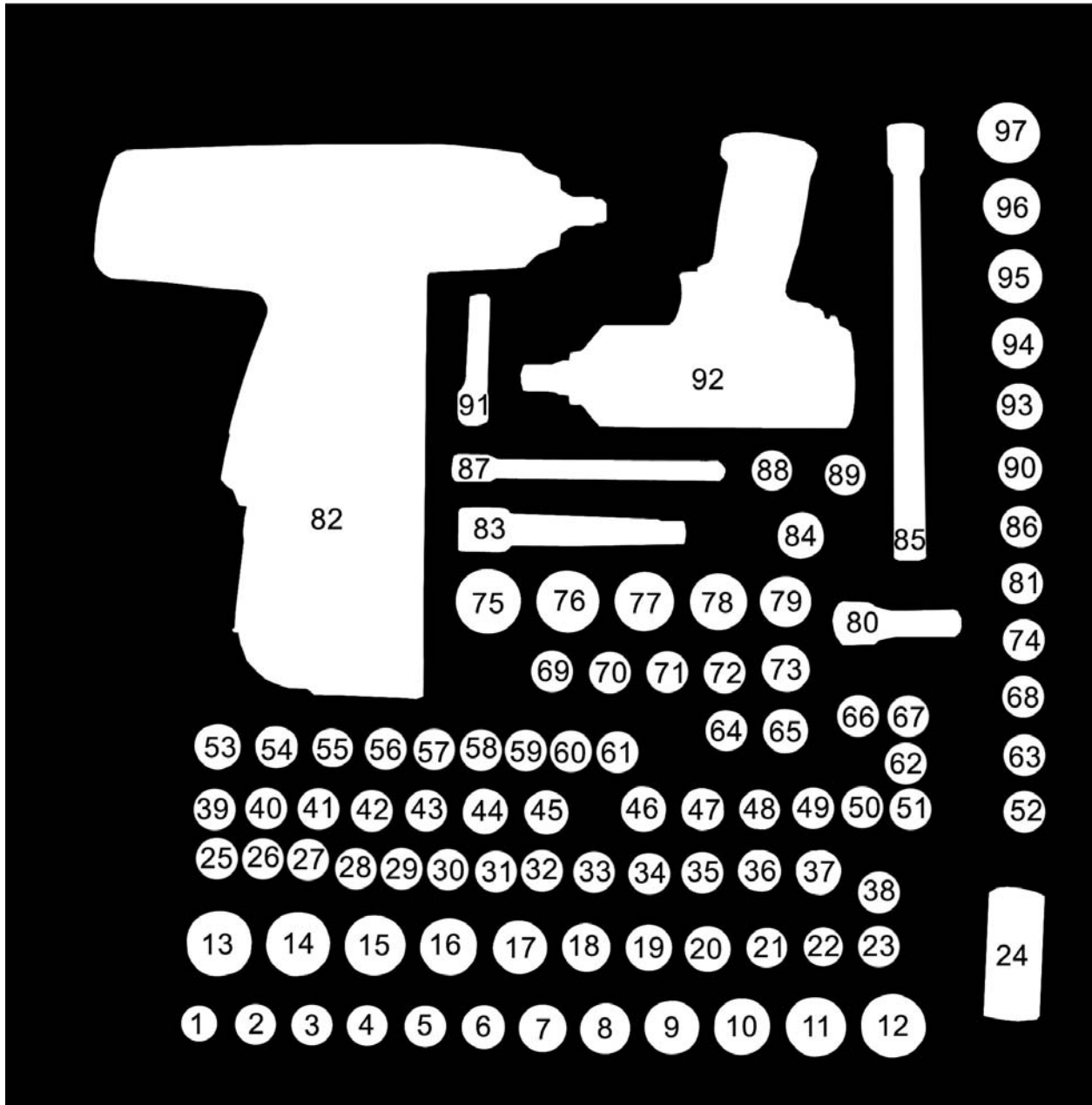

TM 9-4910-783-13&P

SATS BASE TOOL INVENTORY LIST

0058 00

INVENTORY

NOMENCLATURE	QTY	RACK	DRAWER	LOCATION	AMOUNT
SOCKET, IMPACT WRENCH, 1/2" DR, 6 PT, DEEP, 12MM	1	J	3	1	
SOCKET, IMPACT WRENCH, 1/2" DR, 6 PT, DEEP, 13MM	1	J	3	2	
SOCKET, IMPACT WRENCH, 1/2" DR, 6 PT, DEEP, 14MM	1	J	3	3	
SOCKET, IMPACT WRENCH, 1/2" DR, 6 PT, DEEP, 15MM	1	J	3	4	
SOCKET, IMPACT WRENCH, 1/2" DR, 6 PT, DEEP, 16MM	1	J	3	5	
SOCKET, IMPACT WRENCH, 1/2" DR, 6 PT, DEEP, 17MM	1	J	3	6	
SOCKET, IMPACT WRENCH, 1/2" DR, 6 PT, DEEP, 18MM	1	J	3	7	
SOCKET, IMPACT WRENCH, 1/2" DR, 6 PT, DEEP, 19MM	1	J	3	8	
SOCKET, IMPACT WRENCH, 1/2" DR, 6 PT, DEEP, 21MM	1	J	3	9	
SOCKET, IMPACT WRENCH, 1/2" DR, 6 PT, DEEP, 22MM	1	J	3	10	
SOCKET, IMPACT WRENCH, 1/2" DR, 6 PT, DEEP, 24MM	1	J	3	11	
SOCKET, IMPACT WRENCH, 1/2" DR, 6 PT, DEEP, 27MM	1	J	3	12	
SOCKET, IMPACT WRENCH, 1/2" DR, 6 PT, DEEP, 1-1/16"	1	J	3	13	
SOCKET, IMPACT WRENCH, 1/2" DR, 6 PT, DEEP, 1"	1	J	3	14	
SOCKET, IMPACT WRENCH, 1/2" DR, 6 PT, DEEP, 15/16"	1	J	3	15	
SOCKET, IMPACT WRENCH, 1/2" DR, 6 PT, DEEP, 7/8"	1	J	3	16	
SOCKET, IMPACT WRENCH, 1/2" DR, 6 PT, DEEP, 13/16"	1	J	3	17	
SOCKET, IMPACT WRENCH, 1/2" DR, 6 PT, DEEP, 3/4"	1	J	3	18	
SOCKET, IMPACT WRENCH, 1/2" DR, 6 PT, DEEP, 11/16"	1	J	3	19	
SOCKET, IMPACT WRENCH, 1/2" DR, 6 PT, DEEP, 5/8"	1	J	3	20	
SOCKET, IMPACT WRENCH, 1/2" DR, 6 PT, DEEP, 9/16"	1	J	3	21	
SOCKET, IMPACT WRENCH, 1/2" DR, 6 PT, DEEP, 1/2"	1	J	3	22	
SOCKET, IMPACT WRENCH, 1/2" DR, 6 PT, DEEP, 7/16"	1	J	3	23	
SOCKET, DOUBLE-END IMPACT, 3/4" X 13/16"	1	J	3	24	
SOCKET, IMPACT WRENCH, 3/8" DR, 6 PT, DEEP, 12MM	1	J	3	25	
SOCKET, IMPACT WRENCH, 3/8" DR, 6 PT, DEEP, 11MM	1	J	3	26	
SOCKET, IMPACT WRENCH, 3/8" DR, 6 PT, DEEP, 10MM	1	J	3	27	
SOCKET, IMPACT WRENCH, 3/8" DR, 6 PT, 10MM	1	J	3	28	
SOCKET, IMPACT WRENCH, 3/8" DR, 6 PT, 11MM	1	J	3	29	
SOCKET, IMPACT WRENCH, 3/8" DR, 6 PT, 12MM	1	J	3	30	
SOCKET, IMPACT WRENCH, 3/8" DR, 6 PT, 13MM	1	J	3	31	
SOCKET, IMPACT WRENCH, 3/8" DR, 6 PT, 14MM	1	J	3	32	
SOCKET, IMPACT WRENCH, 3/8" DR, 6 PT, 15MM	1	J	3	33	
SOCKET, IMPACT WRENCH, 3/8" DR, 6 PT, 16MM	1	J	3	34	
SOCKET, IMPACT WRENCH, 3/8" DR, 6 PT, 17MM	1	J	3	35	
SOCKET, IMPACT WRENCH, 3/8" DR, 6 PT, 18MM	1	J	3	36	

TM 9-4910-783-13&P

SATS BASE TOOL INVENTORY LIST

0058 00

INVENTORY

NOMENCLATURE	QTY	RACK	DRAWER	LOCATION	AMOUNT
SOCKET, IMPACT WRENCH, 3/8" DR, 6 PT, 19MM	1	J	3	37	
SOCKET, IMPACT WRENCH, 1/2" DR, 6 PT, DEEP, 3/8"	1	J	3	38	
SOCKET, IMPACT WRENCH, 3/8" DR, 6 PT, DEEP, 13MM	1	J	3	39	
SOCKET, IMPACT WRENCH, 3/8" DR, 6 PT, DEEP, 14MM	1	J	3	40	
SOCKET, IMPACT WRENCH, 3/8" DR, 6 PT, DEEP, 15MM	1	J	3	41	
SOCKET, IMPACT WRENCH, 3/8" DR, 6 PT, DEEP, 16MM	1	J	3	42	
SOCKET, IMPACT WRENCH, 3/8" DR, 6 PT, DEEP, 17MM	1	J	3	43	
SOCKET, IMPACT WRENCH, 3/8" DR, 6 PT, DEEP, 18MM	1	J	3	44	
SOCKET, IMPACT WRENCH, 3/8" DR, 6 PT, DEEP, 19MM	1	J	3	45	
SOCKET, IMPACT WRENCH, 3/8" DR, 6 PT, 3/4"	1	J	3	46	
SOCKET, IMPACT WRENCH, 3/8" DR, 6 PT, 11/16"	1	J	3	47	
SOCKET, IMPACT WRENCH, 3/8" DR, 6 PT, 5/8"	1	J	3	48	
SOCKET, IMPACT WRENCH, 3/8" DR, 6 PT, 9/16"	1	J	3	49	
SOCKET, IMPACT WRENCH, 3/8" DR, 6 PT, 1/2"	1	J	3	50	
SOCKET, IMPACT WRENCH, 3/8" DR, 6 PT, 7/16"	1	J	3	51	
SOCKET, IMPACT WRENCH, 1/2" DR, 6 PT, 12MM	1	J	3	52	
SOCKET, IMPACT WRENCH, 3/8" DR, 6 PT, DEEP, 3/4"	1	J	3	53	
SOCKET, IMPACT WRENCH, 3/8" DR, 6 PT, DEEP, 11/16"	1	J	3	54	
SOCKET, IMPACT WRENCH, 3/8" DR, 6 PT, DEEP, 5/8"	1	J	3	55	
SOCKET, IMPACT WRENCH, 3/8" DR, 6 PT, DEEP, 9/16"	1	J	3	56	
SOCKET, IMPACT WRENCH, 3/8" DR, 6 PT, DEEP, 1/2"	1	J	3	57	
SOCKET, IMPACT WRENCH, 3/8" DR, 6 PT, DEEP, 7/16"	1	J	3	58	
SOCKET, IMPACT WRENCH, 3/8" DR, 6 PT, DEEP, 3/8"	1	J	3	59	
SOCKET, IMPACT WRENCH, 3/8" DR, 6 PT, DEEP, 5/16"	1	J	3	60	
SOCKET, IMPACT WRENCH, 3/8" DR, 6 PT, DEEP, 1/4"	1	J	3	61	
SOCKET, IMPACT WRENCH, 3/8" DR, 6 PT, 3/8"	1	J	3	62	
SOCKET, IMPACT WRENCH, 1/2" DR, 6 PT, 13MM	1	J	3	63	
SOCKET, IMPACT WRENCH, 1/2" DR, 6 PT, 5/8"	1	J	3	64	
SOCKET, IMPACT WRENCH, 1/2" DR, 6 PT, 11/16"	1	J	3	65	
SOCKET, IMPACT WRENCH, 3/8" DR, 6 PT, 1/4"	1	J	3	66	
SOCKET, IMPACT WRENCH, 3/8" DR, 6 PT, 5/16"	1	J	3	67	
SOCKET, IMPACT WRENCH, 1/2" DR, 6 PT, 14MM	1	J	3	68	
SOCKET, IMPACT WRENCH, 1/2" DR, 6 PT, 3/8"	1	J	3	69	
SOCKET, IMPACT WRENCH, 1/2" DR, 6 PT, 7/16"	1	J	3	70	
SOCKET, IMPACT WRENCH, 1/2" DR, 6 PT, 1/2"	1	J	3	71	
SOCKET, IMPACT WRENCH, 1/2" DR, 6 PT, 9/16"	1	J	3	72	

TM 9-4910-783-13&P

SATS BASE TOOL INVENTORY LIST

0058 00

INVENTORY

NOMENCLATURE	QTY	RACK	DRAWER	LOCATION	AMOUNT
SOCKET, IMPACT WRENCH, 1/2" DR, 6 PT, 3/4"	1	J	3	73	
SOCKET, IMPACT WRENCH, 1/2" DR, 6 PT, 15MM	1	J	3	74	
SOCKET, IMPACT WRENCH, 1/2" DR, 6 PT, 1-1/16"	1	J	3	75	
SOCKET, IMPACT WRENCH, 1/2" DR, 6 PT, 1"	1	J	3	76	
SOCKET, IMPACT WRENCH, 1/2" DR, 6 PT, 15/16"	1	J	3	77	
SOCKET, IMPACT WRENCH, 1/2" DR, 6 PT, 7/8"	1	J	3	78	
SOCKET, IMPACT WRENCH, 1/2" DR, 6 PT, 13/16"	1	J	3	79	
BAR, EXTENSION, 1/2" DR, 2.5" LONG	1	J	3	80	
SOCKET, IMPACT WRENCH, 1/2" DR, 6 PT, 16MM	1	J	3	81	
WRENCH, ELECTRIC IMPACT, 1/2" SQ DR	1	J	3	82	
BAR, EXTENSION, 1/2" DR, 4.5" LONG	1	J	3	83	
JOINT, UNIVERSAL, 1/2" DR	1	J	3	84	
BAR, EXTENSION, 1/2" DR, 9.5" LONG	1	J	3	85	
SOCKET, IMPACT WRENCH, 1/2" DR, 6 PT, 17MM	1	J	3	86	
BAR, EXTENSION, IMPACT WRENCH, 3/8" DR, 5.5" LONG	1	J	3	87	
ADAPTER, 3/8" DR MALE TO 1/2" DR FEMALE	1	J	3	88	
JOINT, UNIVERSAL, 3/8"	1	J	3	89	
SOCKET, IMPACT WRENCH, 1/2" DR, 6 PT, 18MM	1	J	3	90	
BAR, EXTENSION, IMPACT WRENCH, 3/8" DR, 2.5" LONG	1	J	3	91	
WRENCH, PNEUMATIC IMPACT, 1/2" SQ DR,	1	J	3	92	
SOCKET, IMPACT WRENCH, 1/2" DR, 6 PT, 19MM	1	J	3	93	
SOCKET, IMPACT WRENCH, 1/2" DR, 6 PT, 21MM	1	J	3	94	
SOCKET, IMPACT WRENCH, 1/2" DR, 6 PT, 22MM	1	J	3	95	
SOCKET, IMPACT WRENCH, 1/2" DR, 6 PT, 24MM	1	J	3	96	
SOCKET, IMPACT WRENCH, 1/2" DR, 6 PT, 27MM	1	J	3	97	

TM 9-4910-783-13&P

SATS BASE TOOL INVENTORY LIST

0058 00

J, 4

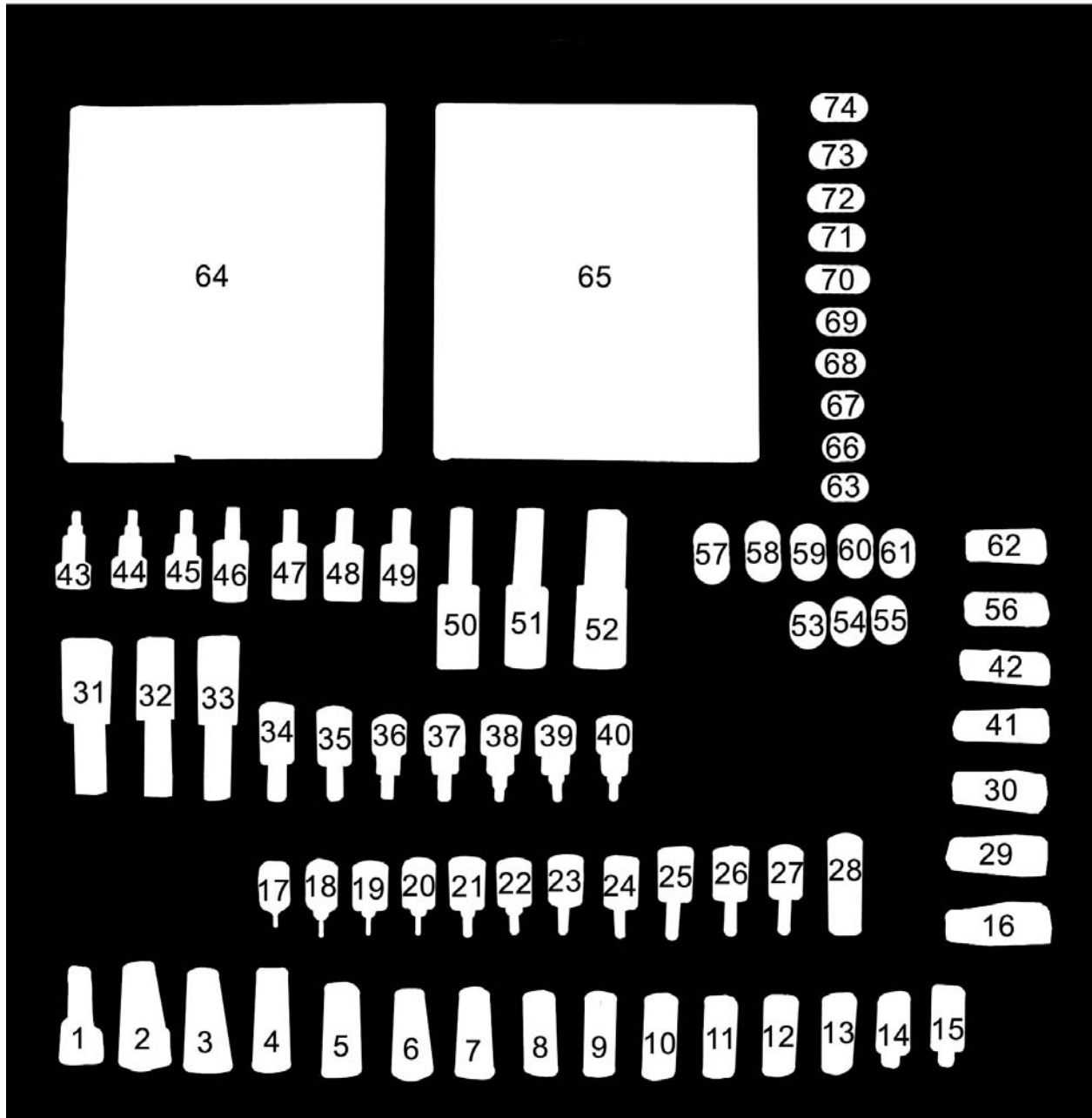

TM 9-4910-783-13&P

SATS BASE TOOL INVENTORY LIST

0058 00

NOMENCLATURE	QTY	RACK	DRAWER	LOCATION	INVENTORY AMOUNT
SOCKET, SOCKET WRENCH, UNIVERSAL, 3/8" DR, 6 PT, 24MM	1	J	4	1	
SOCKET, SOCKET WRENCH, UNIVERSAL, 3/8" DR, 6 PT, 22MM	1	J	4	2	
SOCKET, SOCKET WRENCH, UNIVERSAL, 3/8" DR, 6 PT, 21MM	1	J	4	3	
SOCKET, SOCKET WRENCH, UNIVERSAL, 3/8" DR, 6 PT, 19MM	1	J	4	4	
SOCKET, SOCKET WRENCH, UNIVERSAL, 3/8" DR, 6 PT, 18MM	1	J	4	5	
SOCKET, SOCKET WRENCH, UNIVERSAL, 3/8" DR, 6 PT, 17MM	1	J	4	6	
SOCKET, SOCKET WRENCH, UNIVERSAL, 3/8" DR, 6 PT, 16MM	1	J	4	7	
SOCKET, SOCKET WRENCH, UNIVERSAL, 3/8" DR, 6 PT, 15MM	1	J	4	8	
SOCKET, SOCKET WRENCH, UNIVERSAL, 3/8" DR, 6 PT, 14MM	1	J	4	9	
SOCKET, SOCKET WRENCH, UNIVERSAL, 3/8" DR, 6 PT, 13MM	1	J	4	10	
SOCKET, SOCKET WRENCH, UNIVERSAL, 3/8" DR, 6 PT, 12MM	1	J	4	11	
SOCKET, SOCKET WRENCH, UNIVERSAL, 3/8" DR, 6 PT, 11MM	1	J	4	12	
SOCKET, SOCKET WRENCH, UNIVERSAL, 3/8" DR, 6 PT, 10MM	1	J	4	13	
SOCKET, SOCKET WRENCH, UNIVERSAL, 3/8" DR, 6 PT, 8MM	1	J	4	14	
SOCKET, SOCKET WRENCH, UNIVERSAL, 3/8" DR, 6 PT, 7MM	1	J	4	15	
SOCKET, SOCKET WRENCH, UNIVERSAL, 3/8" DR, 6 PT, 3/4"	1	J	4	16	
SCREWDRIVER ATTACHMENT, TORX BIT, 1/4" DR, T-8	1	J	4	17	
SCREWDRIVER ATTACHMENT, TORX BIT, 1/4" DR, T-10	1	J	4	18	
SCREWDRIVER ATTACHMENT, TORX BIT, 1/4" DR, T-15	1	J	4	19	
SCREWDRIVER ATTACHMENT, TORX BIT, 1/4" DR, T-20	1	J	4	20	
SCREWDRIVER ATTACHMENT, TORX BIT, 1/4" DR, T-25	1	J	4	21	
SCREWDRIVER ATTACHMENT, TORX BIT, 1/4" DR, T-27	1	J	4	22	
SCREWDRIVER ATTACHMENT, TORX BIT, T-30	1	J	4	23	
SCREWDRIVER ATTACHMENT, TORX BIT, 3/8" DR, T-40	1	J	4	24	
SCREWDRIVER ATTACHMENT, TORX BIT, 3/8" DR, T-45	1	J	4	25	
SCREWDRIVER ATTACHMENT, TORX BIT, 3/8" DR, T-47	1	J	4	26	
SCREWDRIVER ATTACHMENT, TORX BIT, 3/8" DR, T-50	1	J	4	27	
SCREWDRIVER ATTACHMENT, TORX BIT, 3/8" DR, T-55	1	J	4	28	
SOCKET, SOCKET WRENCH, UNIVERSAL, 3/8" DR, 6 PT, 11/16"	1	J	4	29	
SOCKET, SOCKET WRENCH, UNIVERSAL, 3/8" DR, 6 PT, 5/8"	1	J	4	30	
SCREWDRIVER ATTACHMENT HEX, 1/2" DR, 5/8"	1	J	4	31	
SCREWDRIVER ATTACHMENT HEX, 1/2" DR, 9/16"	1	J	4	32	
SCREWDRIVER ATTACHMENT HEX, 1/2" DR, 1/2"	1	J	4	33	
SCREWDRIVER ATTACHMENT HEX, 3/8" DR, 3/8"	1	J	4	34	
SCREWDRIVER ATTACHMENT HEX, 3/8" DR, 5/16"	1	J	4	35	
SCREWDRIVER ATTACHMENT HEX, 3/8" DR, 1/4"	1	J	4	36	

TM 9-4910-783-13&P

SATS BASE TOOL INVENTORY LIST

0058 00

NOMENCLATURE	QTY	RACK	DRAWER	LOCATION	AMOUNT
SCREWDRIVER ATTACHMENT HEX, 3/8" DR, 7/32"	1	J	4	37	
SCREWDRIVER ATTACHMENT HEX, 3/8" DR, 3/16"	1	J	4	38	
SCREWDRIVER ATTACHMENT HEX, 3/8" DR, 5/32"	1	J	4	39	
SCREWDRIVER ATTACHMENT HEX, 3/8" DR, 1/8"	1	J	4	40	
SOCKET, SOCKET WRENCH, UNIVERSAL, 3/8" DR, 6 PT, 9/16"	1	J	4	41	
SOCKET, SOCKET WRENCH, UNIVERSAL, 3/8" DR, 6 PT, 1/2"	1	J	4	42	
SCREWDRIVER ATTACHMENT HEX, 3/8" DR, 4MM	1	J	4	43	
SCREWDRIVER ATTACHMENT HEX, 3/8" DR, 5MM	1	J	4	44	
SCREWDRIVER ATTACHMENT HEX, 3/8" DR, 6MM	1	J	4	45	
SCREWDRIVER ATTACHMENT HEX, 3/8" DR, 7MM	1	J	4	46	
SCREWDRIVER ATTACHMENT HEX, 3/8" DR, 8MM	1	J	4	47	
SCREWDRIVER ATTACHMENT HEX, 3/8" DR, 9MM	1	J	4	48	
SCREWDRIVER ATTACHMENT HEX, 3/8" DR, 10MM	1	J	4	49	
SCREWDRIVER ATTACHMENT HEX, 1/2" DR, 12MM	1	J	4	50	
SCREWDRIVER ATTACHMENT HEX, 1/2" DR, 14MM	1	J	4	51	
SCREWDRIVER ATTACHMENT HEX, 1/2" DR, 17MM	1	J	4	52	
CROWFOOT ATTACHMENT, FLARE NUT, 3/8" DR, 3/8"	1	J	4	53	
CROWFOOT ATTACHMENT, FLARE NUT, 3/8" DR, 7/16"	1	J	4	54	
CROWFOOT ATTACHMENT, FLARE NUT, 3/8" DR, 1/2"	1	J	4	55	
SOCKET, SOCKET WRENCH, UNIVERSAL, 3/8" DR, 6 PT, 7/16"	1	J	4	56	
CROWFOOT ATTACHMENT, FLARE NUT, 3/8" DR, 13/16"	1	J	4	57	
CROWFOOT ATTACHMENT, FLARE NUT, 3/8" DR, 3/4"	1	J	4	58	
CROWFOOT ATTACHMENT, FLARE NUT, 3/8" DR, 11/16"	1	J	4	59	
CROWFOOT ATTACHMENT, FLARE NUT, 3/8" DR, 5/8"	1	J	4	60	
CROWFOOT ATTACHMENT, FLARE NUT, 3/8" DR, 9/16"	1	J	4	61	
SOCKET, SOCKET WRENCH, UNIVERSAL, 3/8" DR, 6PT, 3/8"	1	J	4	62	
CROWFOOT ATTACHMENT, FLARE NUT, 3/8" DR, 9MM	1	J	4	63	
KEY SET, HEX, STANDARD	1	J	4	64	
KEY SET, HEX, METRIC	1	J	4	65	
CROWFOOT ATTACHMENT, FLARE NUT, 3/8" DR, 10MM	1	J	4	66	
CROWFOOT ATTACHMENT, FLARE NUT, 3/8" DR, 11MM	1	J	4	67	
CROWFOOT ATTACHMENT, FLARE NUT, 3/8" DR, 12MM	1	J	4	68	
CROWFOOT ATTACHMENT, FLARE NUT, 3/8" DR, 13MM	1	J	4	69	
CROWFOOT ATTACHMENT, FLARE NUT, 3/8" DR, 14MM	1	J	4	70	
CROWFOOT ATTACHMENT, FLARE NUT, 3/8" DR, 15MM	1	J	4	71	
CROWFOOT ATTACHMENT, FLARE NUT, 3/8" DR, 16MM	1	J	4	72	

TM 9-4910-783-13&P

SATS BASE TOOL INVENTORY LIST

0058 00

					INVENTORY
NOMENCLATURE	QTY	RACK	DRAWER	LOCATION	AMOUNT
CROWFOOT ATTACHMENT, FLARE NUT, 3/8" DR, 17MM	1	J	4	73	
CROWFOOT ATTACHMENT, FLARE NUT, 3/8" DR, 18MM	1	J	4	74	

TM 9-4910-783-13&P

J, 5

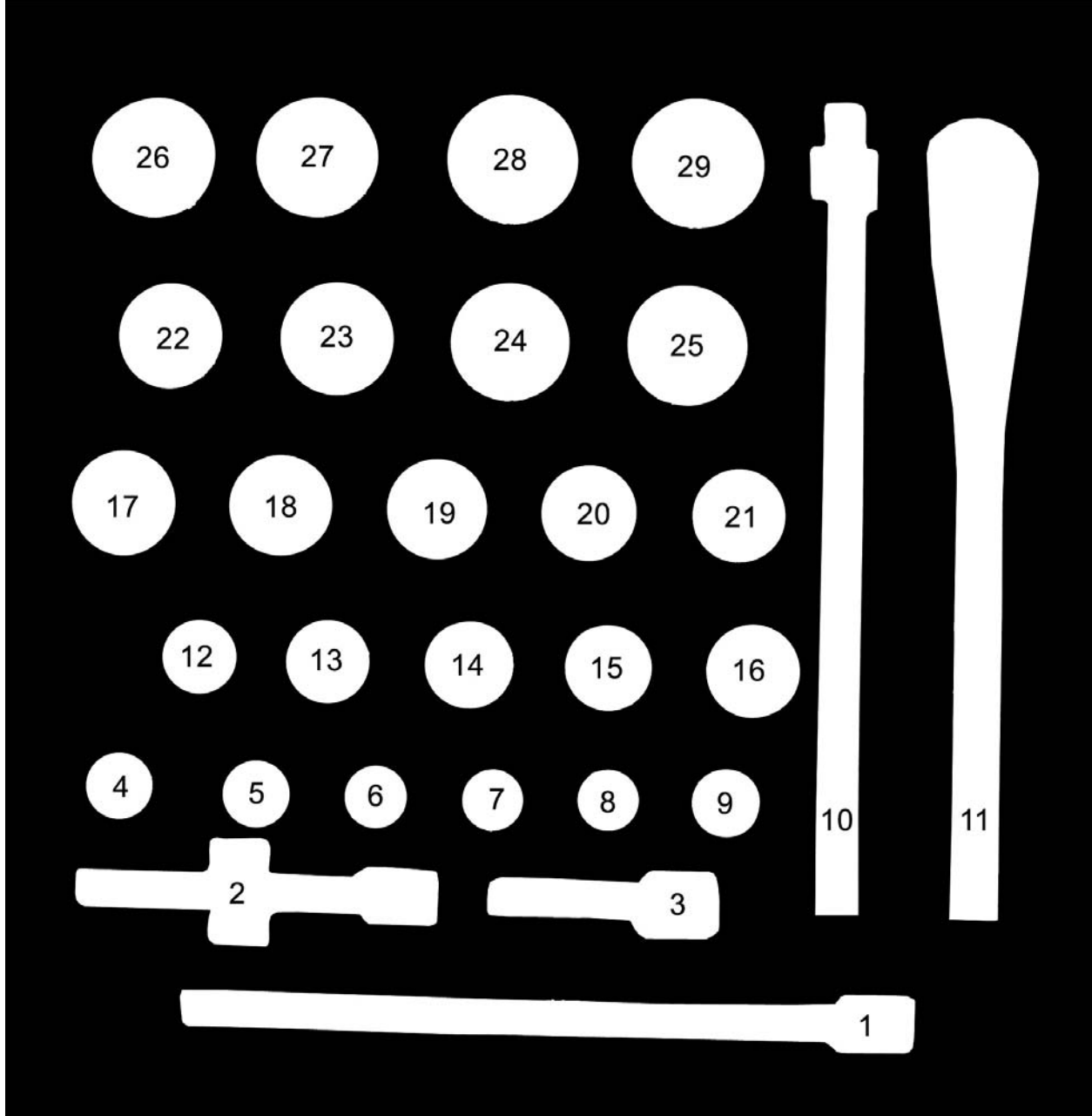

TM 9-4910-783-13&P

SATS BASE TOOL INVENTORY LIST

0058 00

INVENTORY

NOMENCLATURE	QTY	RACK	DRAWER	LOCATION	AMOUNT
EXTENSION, 3/4" DR, 15" LONG	1	J	5	1	
EXTENSION, 3/4" DR, 7.5" LONG	1	J	5	2	
EXTENSION, 3/4" DR, 4.5" LONG	1	J	5	3	
SOCKET, SOCKET WRENCH, 3/4" DR, 12 PT, 1-1/16"	1	J	5	4	
SOCKET, SOCKET WRENCH, 3/4" DR, 12 PT, 1"	1	J	5	5	
SOCKET, SOCKET WRENCH, 3/4" DR, 12 PT, 15/16"	1	J	5	6	
SOCKET, SOCKET WRENCH, 3/4" DR, 12 PT, 7/8"	1	J	5	7	
ADAPTER, 3/4" DR TO 1/2" DR, 1/2"	1	J	5	8	
JOINT, UNIVERSAL, 3/4"	1	J	5	9	
HANDLE, SLIDING-T, 3/4" DR, 17" LONG	1	J	5	10	
HANDLE, RATCHET, 3/4" DR, 17" LONG	1	J	5	11	
SOCKET, SOCKET WRENCH, 3/4" DR, 12 PT, 1-1/8"	1	J	5	12	
SOCKET, SOCKET WRENCH, 3/4" DR, 12 PT, 1 1/4"	1	J	5	13	
SOCKET, SOCKET WRENCH, 3/4" DR, 12 PT, 1 5/16"	1	J	5	14	
SOCKET, SOCKET WRENCH, 3/4" DR, 12 PT, 1 3/8"	1	J	5	15	
SOCKET, SOCKET WRENCH, 3/4" DR, 12 PT, 1-7/16"	1	J	5	16	
SOCKET, SOCKET WRENCH, 3/4" DR, 12 PT, 1-3/4"	1	J	5	17	
SOCKET, SOCKET WRENCH, 3/4" DR, 12 PT, 1-11/16"	1	J	5	18	
SOCKET, SOCKET WRENCH, 3/4" DR, 12 PT, 1-5/8"	1	J	5	19	
SOCKET, SOCKET WRENCH, 3/4" DR, 12 PT, 1-9/16"	1	J	5	20	
SOCKET, SOCKET WRENCH, 3/4" DR, 12 PT, 1-1/2"	1	J	5	21	
SOCKET, SOCKET WRENCH, 3/4" DR, 12 PT, 1-13/16"	1	J	5	22	
SOCKET, SOCKET WRENCH, 3/4" DR, 12 PT, 1-7/8"	1	J	5	23	
SOCKET, SOCKET WRENCH, 3/4" DR, 12 PT, 2"	1	J	5	24	
SOCKET, SOCKET WRENCH, 3/4" DR, 12 PT, 2-1/16"	1	J	5	25	
SOCKET, SOCKET WRENCH, 3/4" DR, 12 PT, 2-1/8"	1	J	5	26	
SOCKET, SOCKET WRENCH, 3/4" DR, 12 PT, 2-3/16"	1	J	5	27	
SOCKET, SOCKET WRENCH, 3/4" DR, 12 PT, 2-1/4"	1	J	5	28	
SOCKET, SOCKET WRENCH, 3/4" DR, 12 PT, 2-3/8"	1	J	5	29	

TM 9-4910-783-13&P

J, 6

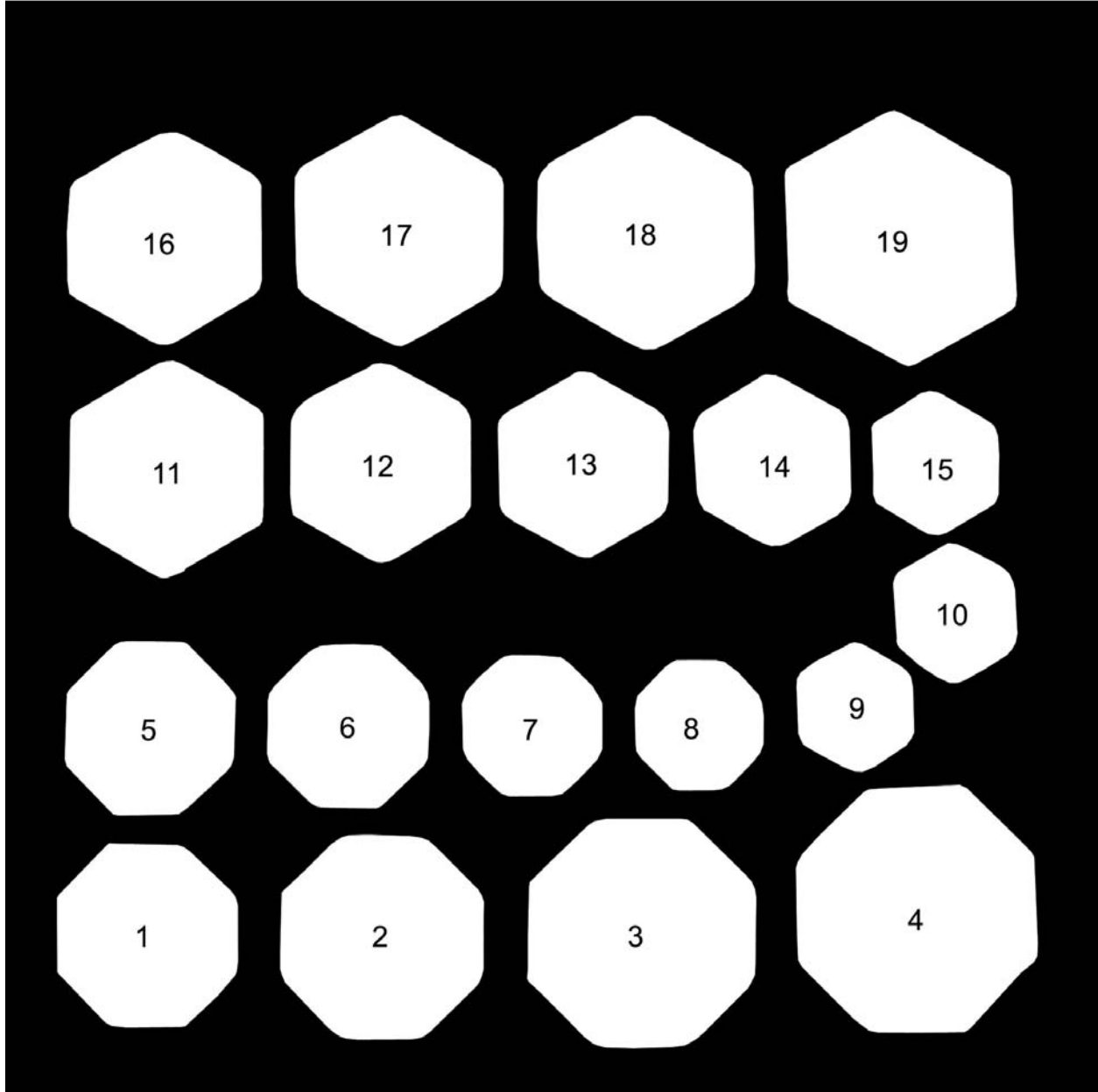

TM 9-4910-783-13&P

SATS BASE TOOL INVENTORY LIST

0058 00

INVENTORY

NOMENCLATURE	QTY	RACK	DRAWER	LOCATION	AMOUNT
SOCKET, SOCKET WRENCH, WHEEL BEARING LOCKNUT, 3/4" DR, 8 PT, 3-1/2"	1	J	6	1	
SOCKET, SOCKET WRENCH, WHEEL BEARING LOCKNUT, 3/4" DR, 8 PT, 3-7/8"	1	J	6	2	
SOCKET, SOCKET WRENCH, WHEEL BEARING LOCKNUT, 3/4" DR, 8 PT, 4-3/8"	1	J	6	3	
SOCKET, SOCKET WRENCH, WHEEL BEARING LOCKNUT, 3/4" DR, 8 PT, 4-7/8"	1	J	6	4	
SOCKET, SOCKET WRENCH, WHEEL BEARING LOCKNUT, 3/4" DR, 8 PT, 3-1/4"	1	J	6	5	
SOCKET, SOCKET WRENCH, WHEEL BEARING LOCKNUT, 3/4" DR, 8 PT, 3"	1	J	6	6	
SOCKET, SOCKET WRENCH, WHEEL BEARING LOCKNUT, 3/4" DR, 8 PT, 2-9/16"	1	J	6	7	
SOCKET, SOCKET WRENCH, WHEEL BEARING LOCKNUT, 3/4" DR, 8 PT, 2-3/8"	1	J	6	8	
SOCKET, SOCKET WRENCH, WHEEL BEARING LOCKNUT, 3/4" DR, 6 PT, 2-3/32"	1	J	6	9	
SOCKET, SOCKET WRENCH, WHEEL BEARING LOCKNUT, 3/4" DR, 6 PT, 2-3/8"	1	J	6	10	
SOCKET, SOCKET WRENCH, WHEEL BEARING LOCKNUT, 3/4" DR, 6 PT, 3-7/8"	1	J	6	11	
SOCKET, SOCKET WRENCH, WHEEL BEARING LOCKNUT, 3/4" DR, 6 PT, 3-1/2"	1	J	6	12	
SOCKET, SOCKET WRENCH, WHEEL BEARING LOCKNUT, 3/4" DR, 6 PT, 3-1/4"	1	J	6	13	
SOCKET, SOCKET WRENCH, WHEEL BEARING LOCKNUT, 3/4" DR, 6 PT, 3"	1	J	6	14	
SOCKET, SOCKET WRENCH, WHEEL BEARING LOCKNUT, 3/4" DR, 6 PT, 2-9/16"	1	J	6	15	
SOCKET, SOCKET WRENCH, WHEEL BEARING LOCKNUT, 3/4" DR, 6 PT, 4"	1	J	6	16	
SOCKET, SOCKET WRENCH, WHEEL BEARING LOCKNUT, 3/4" DR, 6 PT, 4-1/8"	1	J	6	17	
SOCKET, SOCKET WRENCH, WHEEL BEARING LOCKNUT, 3/4" DR, 6 PT, 4-3/8"	1	J	6	18	
SOCKET, SOCKET WRENCH, WHEEL BEARING LOCKNUT, 3/4" DR, 6 PT, 4-7/8"	1	J	6	19	

TM 9-4910-783-13&P

SATS BASE TOOL INVENTORY LIST

0058 00

NOMENCLATURE					INVENTORY
	QTY	RACK	DRAWER	LOCATION	AMOUNT
DIE AND TAP SET, RETHREADING	1	J	7	1	
DIE AND TAP SET, THREAD	1	J	7	2	

J, 7

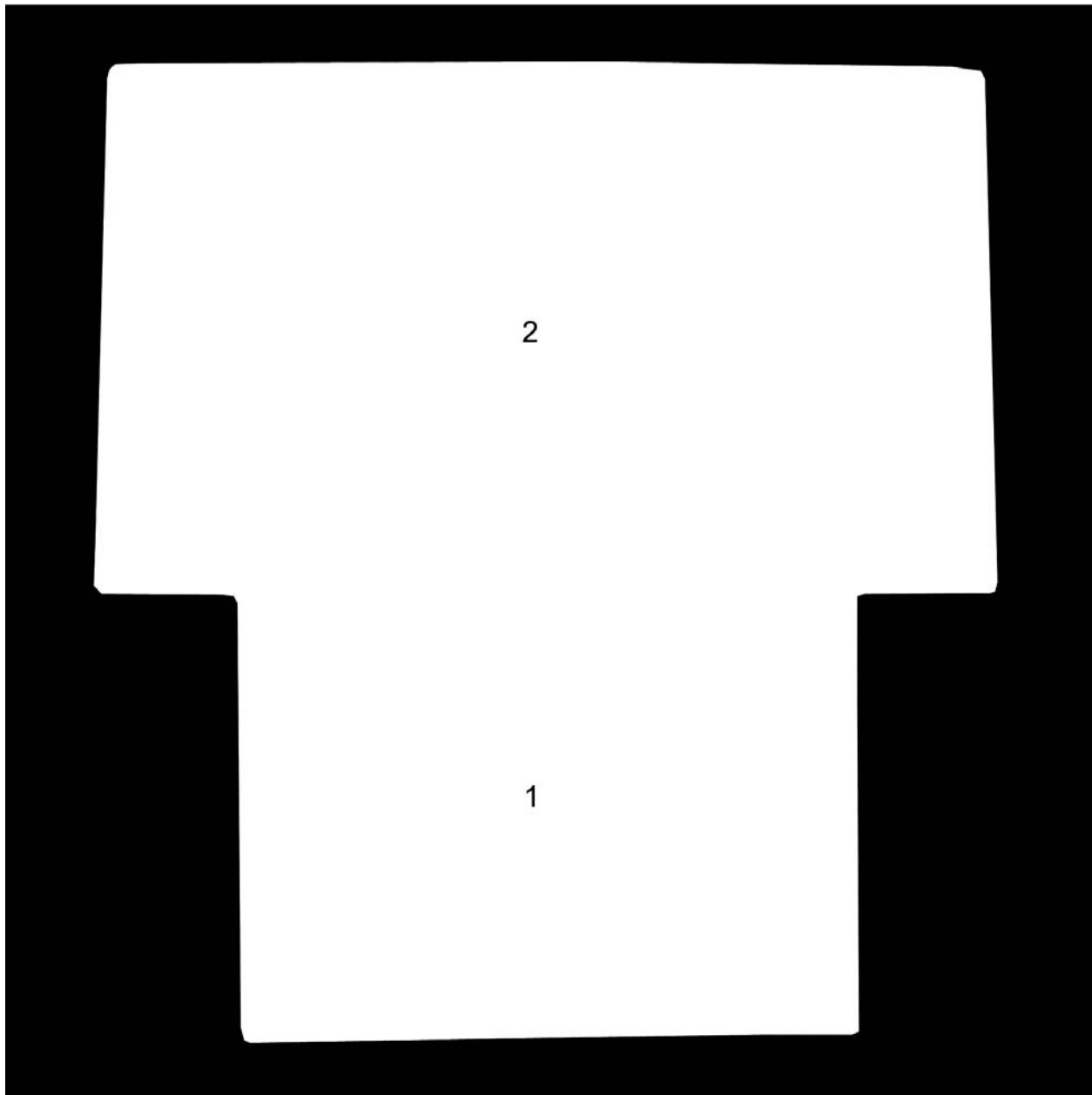

TM 9-4910-783-13&P

SATS BASE TOOL INVENTORY LIST

0058 00

NOMENCLATURE	INVENTORY				
	QTY	RACK	DRAWER	LOCATION	AMOUNT
PLIERS, LOCK RING	1	J	8	1	
PLIERS SET, RETAINING RING	1	J	8	2	
PLIERS, LOCK RING	1	J	8	3	
TOOL KIT, SCREW INSERT	1	J	8	4	

J, 8

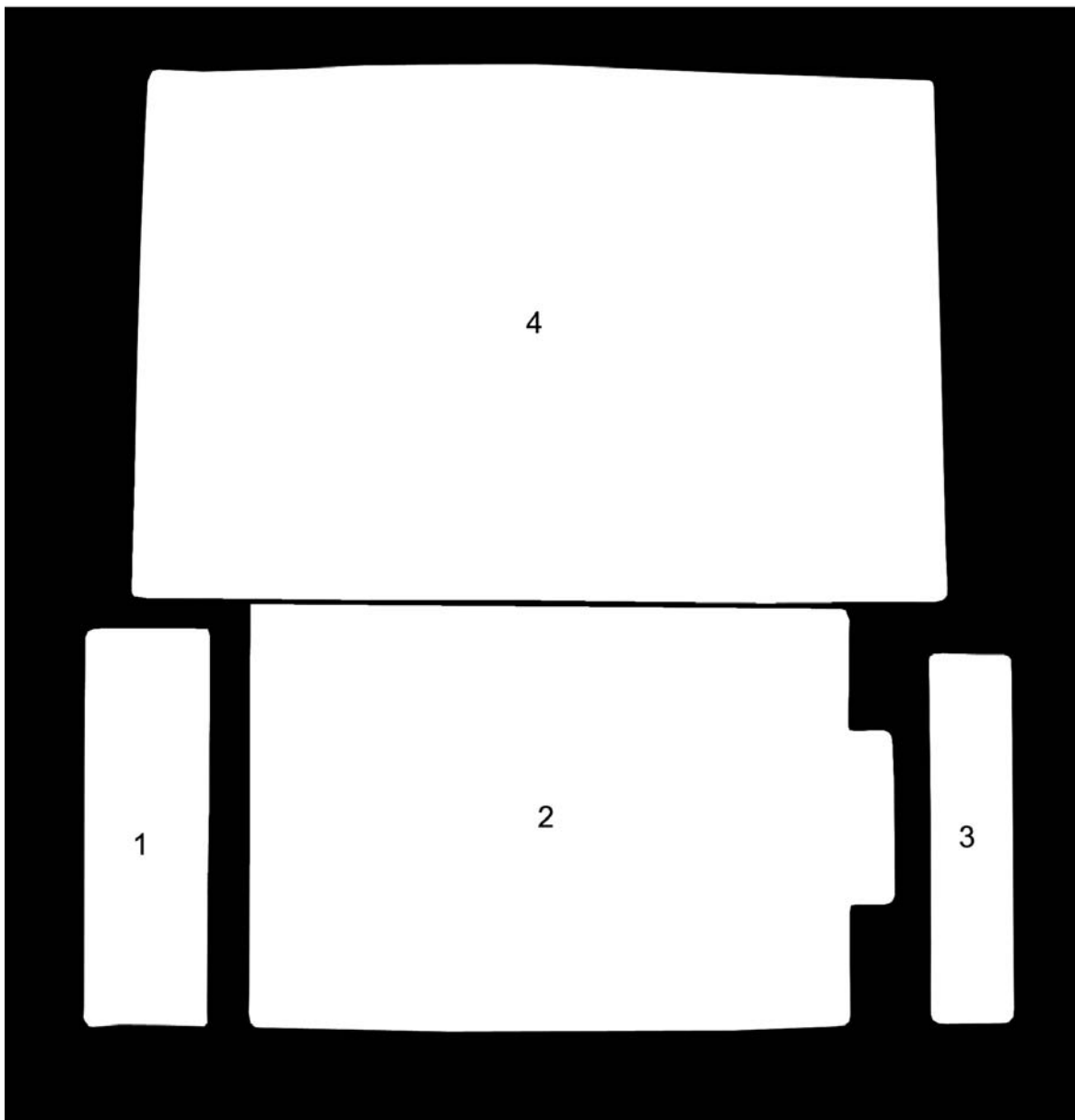

TM 9-4910-783-13&P

SATS BASE TOOL INVENTORY LIST

0058 00

NOMENCLATURE	INVENTORY				
	QTY	RACK	DRAWER	LOCATION	AMOUNT
TAPE, MEASURING, 25'	1	J	9	1	
TOOL KIT, BLIND, FASTENER, INSTALLATION	1	J	9	2	

J, 9

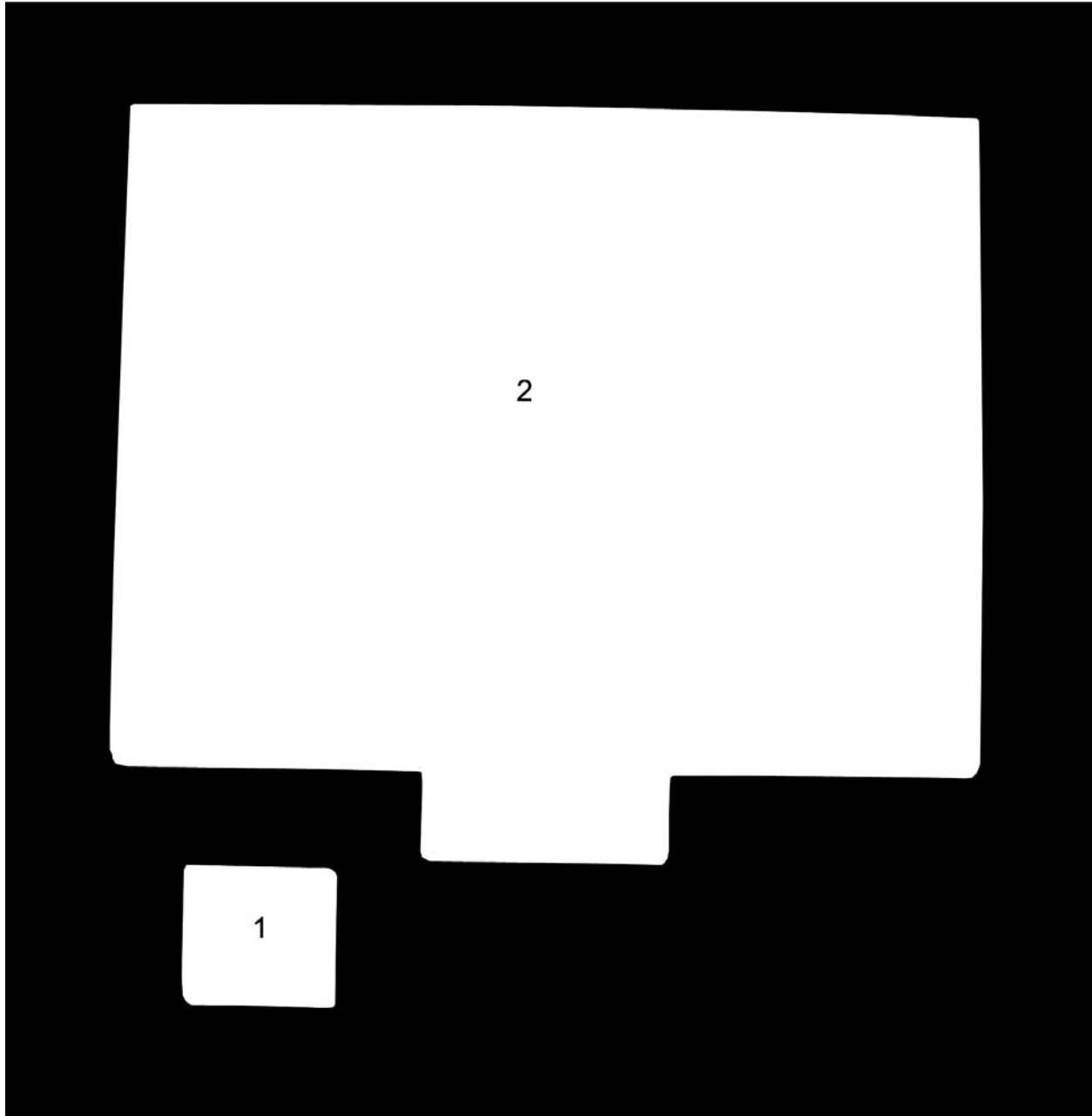

TM 9-4910-783-13&P

SATS BASE TOOL INVENTORY LIST

0058 00

NOMENCLATURE	INVENTORY				
	QTY	RACK	DRAWER	LOCATION	AMOUNT
CRIMPING TOOL, TERMINAL	1	J	10	2	
SOLDERING GUN	1	J	10	3	
PLIERS, WIRE TWISTER	1	J	10	5	
MULTIMETER	2	J	10	1,4	

J, 10

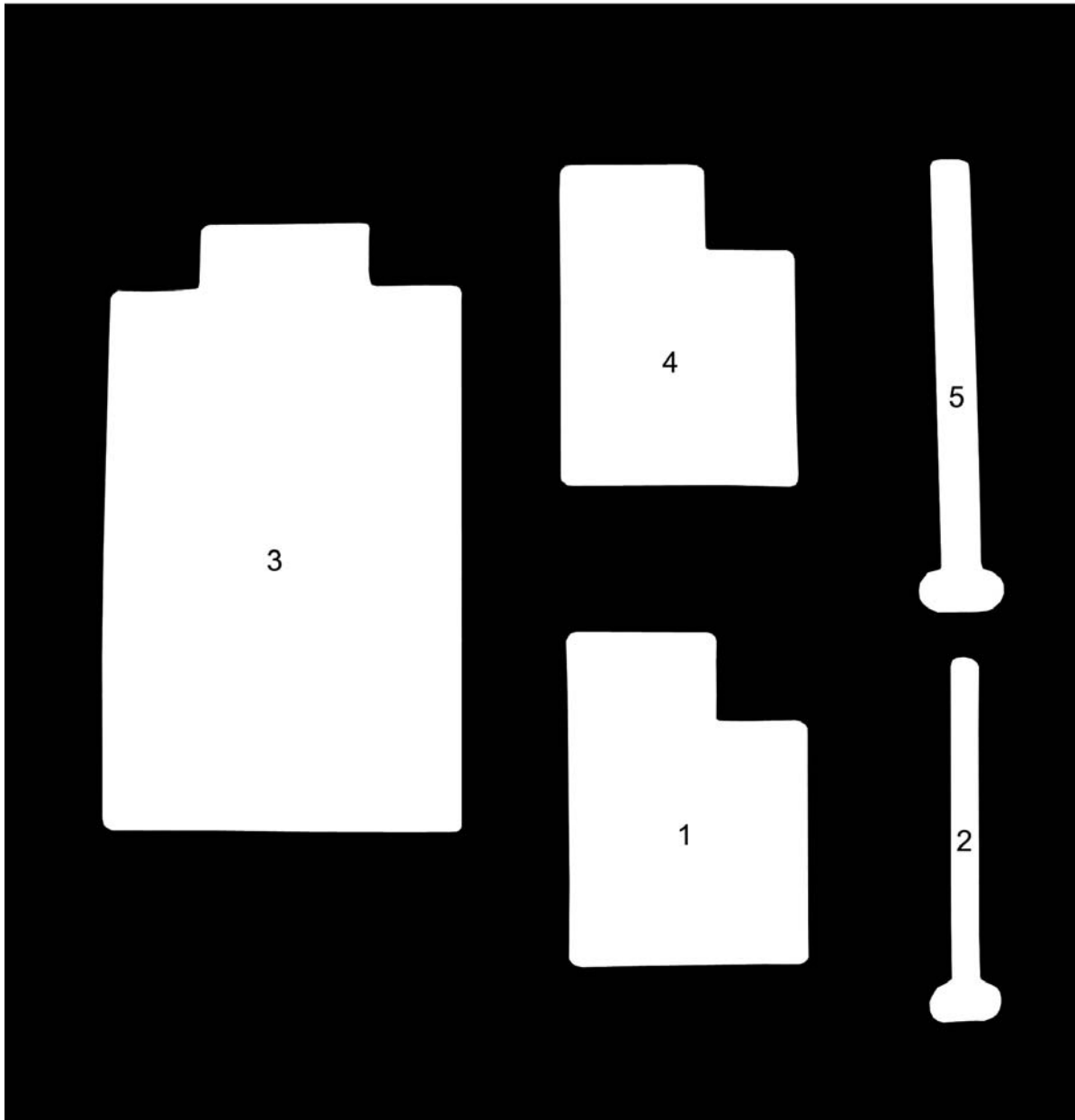

TM 9-4910-783-13&P

SATS BASE TOOL INVENTORY LIST

0058 00

NOMENCLATURE	INVENTORY				
	QTY	RACK	DRAWER	LOCATION	AMOUNT
MULTIPLIER, TORQUE	1	K	1	1	
WRENCH, TORQUE, DIAL, 3/8" DRIVE, 300 LB-IN Nm	1	K	1	2	
MULTIPLIER, TORQUE, BAR	1	K	1	3	
WRENCH, TORQUE, CLICK, 1/2" DRIVE, 345 Nm	1	K	1	4	
WRENCH, TORQUE, CLICK, RATCHETING, 1/2" DRIVE, 250 FT-LB	1	K	1	5	
WRENCH, TORQUE, CLICK, RATCHETING, 3/8" DRIVE, 75 FT-LB	1	K	1	6	
WRENCH, TORQUE, DIAL, 1/4" DRIVE, 30 LB-IN Nm	1	K	1	7	

K, 1

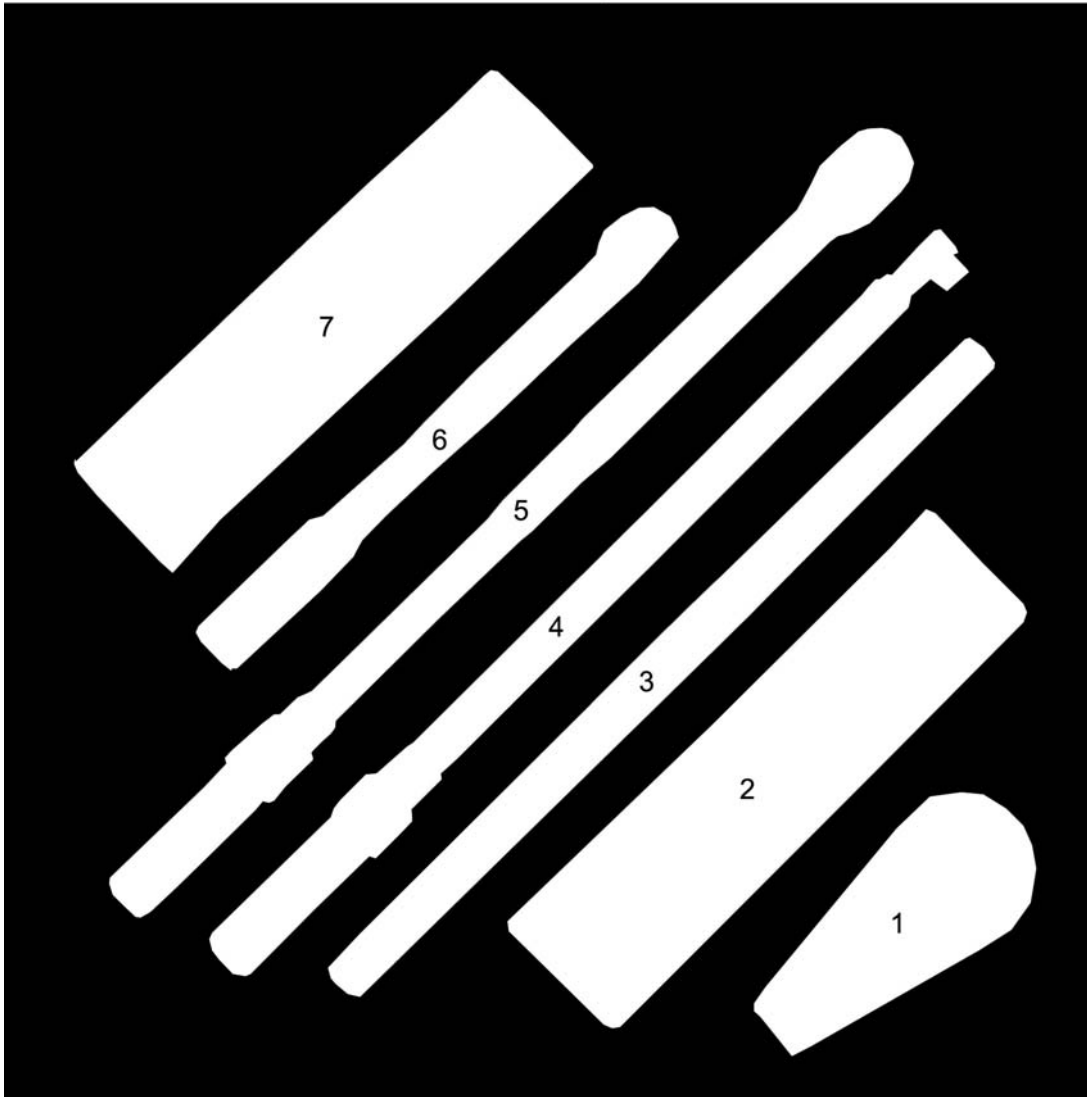

TM 9-4910-783-13&P

SATS BASE TOOL INVENTORY LIST

0058 00

THIS PAGE INTENTIONALLY LEFT BLANK

TM 9-4910-783-13&P

SATS BASE TOOL INVENTORY LIST

0058 00

K, 2

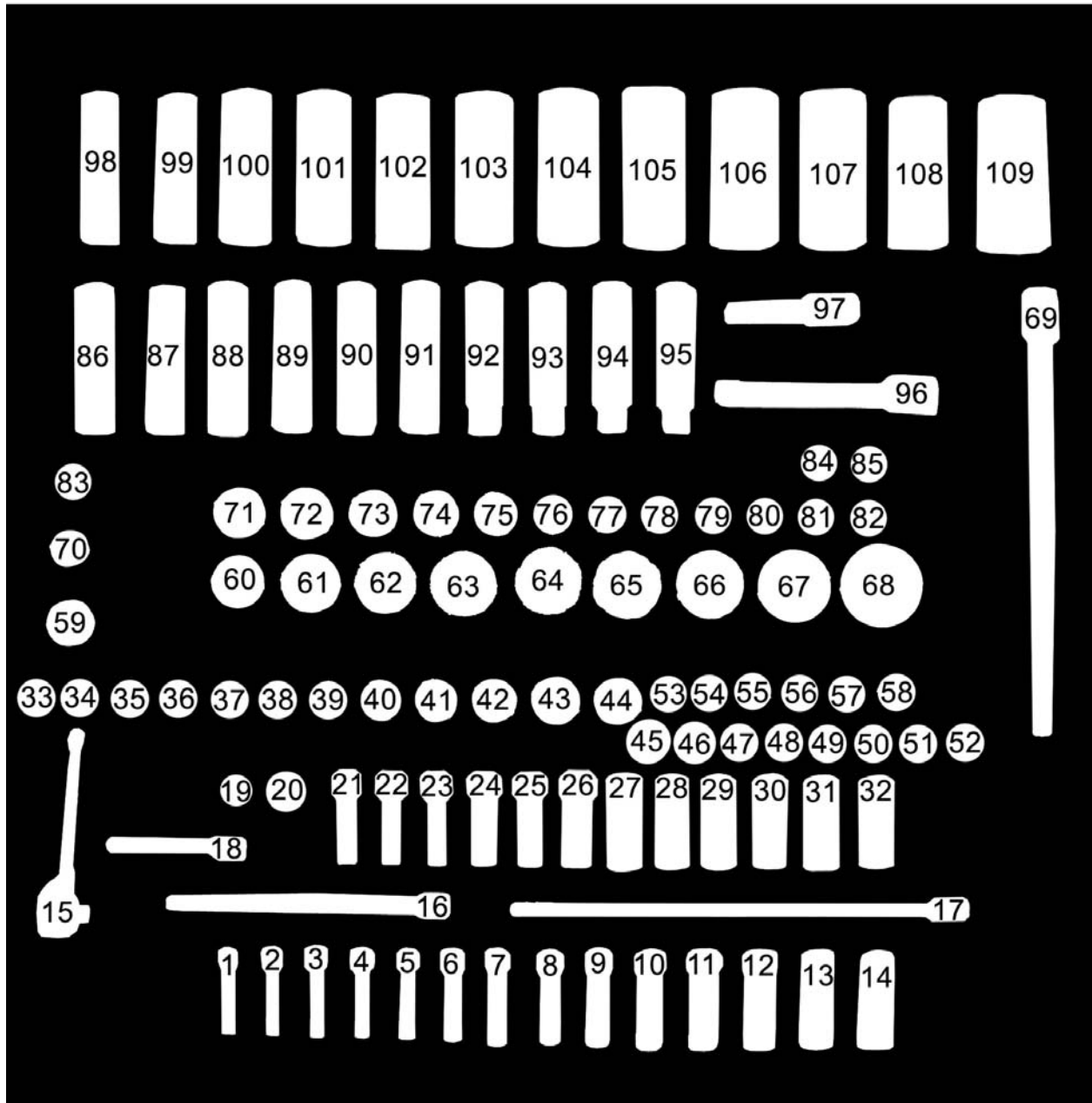

TM 9-4910-783-13&P

SATS BASE TOOL INVENTORY LIST

0058 00

INVENTORY

NOMENCLATURE	QTY	RACK	DRAWER	LOCATION	AMOUNT
SOCKET, SOCKET WRENCH, 1/4" DR, 6 PT, DEEP, 4MM	1	K	2	1	
SOCKET, SOCKET WRENCH, 1/4" DR, 6 PT, DEEP, 4.5MM	1	K	2	2	
SOCKET, SOCKET WRENCH, 1/4" DR, 6 PT, DEEP, 5MM	1	K	2	3	
SOCKET, SOCKET WRENCH, 1/4" DR, 6 PT, DEEP, 5.5MM	1	K	2	4	
SOCKET, SOCKET WRENCH, 1/4" DR, 6 PT, DEEP, 6MM	1	K	2	5	
SOCKET, SOCKET WRENCH, 1/4" DR, 6 PT, DEEP, 7MM	1	K	2	6	
SOCKET, SOCKET WRENCH, 1/4" DR, 6 PT, DEEP, 8MM	1	K	2	7	
SOCKET, SOCKET WRENCH, 1/4" DR, 6 PT, DEEP, 9MM	1	K	2	8	
SOCKET, SOCKET WRENCH, 1/4" DR, 6 PT, DEEP, 10MM	1	K	2	9	
SOCKET, SOCKET WRENCH, 1/4" DR, 6 PT, DEEP, 11MM	1	K	2	10	
SOCKET, SOCKET WRENCH, 1/4" DR, 6 PT, DEEP, 12MM	1	K	2	11	
SOCKET, SOCKET WRENCH, 1/4" DR, 6 PT, DEEP, 13MM	1	K	2	12	
SOCKET, SOCKET WRENCH, 1/4" DR, 6 PT, DEEP, 14MM	1	K	2	13	
SOCKET, SOCKET WRENCH, 1/4" DR, 6 PT, DEEP, 15MM	1	K	2	14	
HANDLE, REVERSIBLE RATCHET, SOCKET WRENCH, 1/4" DR, 4.375" LONG	1	K	2	15	
EXTENSION, 1/4" DR, 5.5" LONG	1	K	2	16	
EXTENSION, 1/4" DR, 9.5" LONG	1	K	2	17	
EXTENSION, 1/4" DR, 2.5" LONG	1	K	2	18	
ADAPTER, SOCKET WRENCH DRIVE, 3/8" MALE - 1/4" FEMALE	1	K	2	19	
JOINT, UNIVERSAL, 1/4" DR	1	K	2	20	
SOCKET, SOCKET WRENCH, 1/4" DR, 6 PT, DEEP, 1/8"	1	K	2	21	
SOCKET, SOCKET WRENCH, 1/4" DR, 6 PT, DEEP, 5/32"	1	K	2	22	
SOCKET, SOCKET WRENCH, 1/4" DR, 6 PT, DEEP, 3/16"	1	K	2	23	
SOCKET, SOCKET WRENCH, 1/4" DR, 6 PT, DEEP, 7/32"	1	K	2	24	
SOCKET, SOCKET WRENCH, 1/4" DR, 6 PT, DEEP, 1/4"	1	K	2	25	
SOCKET, SOCKET WRENCH, 1/4" DR, 6 PT, DEEP, 9/32"	1	K	2	26	
SOCKET, SOCKET WRENCH, 1/4" DR, 6 PT, DEEP, 5/16"	1	K	2	27	
SOCKET, SOCKET WRENCH, 1/4" DR, 6 PT, DEEP, 11/32"	1	K	2	28	
SOCKET, SOCKET WRENCH, 1/4" DR, 6 PT, DEEP, 3/8"	1	K	2	29	
SOCKET, SOCKET WRENCH, 1/4" DR, 6 PT, DEEP, 7/16"	1	K	2	30	
SOCKET, SOCKET WRENCH, 1/4" DR, 6 PT, DEEP, 1/2"	1	K	2	31	
SOCKET, SOCKET WRENCH, 1/4" DR, 6 PT, DEEP, 9/16"	1	K	2	32	
SOCKET, SOCKET WRENCH, 1/4" DR, 6 PT, REGULAR, 9/16"	1	K	2	33	
SOCKET, SOCKET WRENCH, 1/4" DR, 6 PT, REGULAR, 1/2"	1	K	2	34	
SOCKET, SOCKET WRENCH, 1/4" DR, 6 PT, REGULAR, 7/16"	1	K	2	35	
SOCKET, SOCKET WRENCH, 1/4" DR, 6 PT, REGULAR, 3/8"	1	K	2	36	

TM 9-4910-783-13&P

SATS BASE TOOL INVENTORY LIST

0058 00

INVENTORY

NOMENCLATURE	QTY	RACK	DRAWER	LOCATION	AMOUNT
SOCKET, SOCKET WRENCH, 1/4" DR, 6 PT, REGULAR, 11/32"	1	K	2	37	
SOCKET, SOCKET WRENCH, 1/4" DR, 6 PT, REGULAR, 5/16"	1	K	2	38	
SOCKET, SOCKET WRENCH, 1/4" DR, 6 PT, REGULAR, 9/32"	1	K	2	39	
SOCKET, SOCKET WRENCH, 1/4" DR, 6 PT, REGULAR, 1/4"	1	K	2	40	
SOCKET, SOCKET WRENCH, 1/4" DR, 6 PT, REGULAR, 7/32"	1	K	2	41	
SOCKET, SOCKET WRENCH, 1/4" DR, 6 PT, REGULAR, 3/16"	1	K	2	42	
SOCKET, SOCKET WRENCH, 1/4" DR, 6 PT, REGULAR, 5/32"	1	K	2	43	
SOCKET, SOCKET WRENCH, 1/4" DR, 6 PT, REGULAR, 1/8"	1	K	2	44	
SOCKET, SOCKET WRENCH, 1/4" DR, 6 PT, REGULAR, 9MM	1	K	2	45	
SOCKET, SOCKET WRENCH, 1/4" DR, 6 PT, REGULAR, 8MM	1	K	2	46	
SOCKET, SOCKET WRENCH, 1/4" DR, 6 PT, REGULAR, 7MM	1	K	2	47	
SOCKET, SOCKET WRENCH, 1/4" DR, 6 PT, REGULAR, 6MM	1	K	2	48	
SOCKET, SOCKET WRENCH, 1/4" DR, 6 PT, REGULAR, 5.5MM	1	K	2	49	
SOCKET, SOCKET WRENCH, 1/4" DR, 6 PT, REGULAR, 5MM	1	K	2	50	
SOCKET, SOCKET WRENCH, 1/4" DR, 6 PT, REGULAR, 4.5MM	1	K	2	51	
SOCKET, SOCKET WRENCH, 1/4" DR, 6 PT, REGULAR, 4MM	1	K	2	52	
SOCKET, SOCKET WRENCH, 1/4" DR, 6 PT, REGULAR, 10MM	1	K	2	53	
SOCKET, SOCKET WRENCH, 1/4" DR, 6 PT, REGULAR, 11MM	1	K	2	54	
SOCKET, SOCKET WRENCH, 1/4" DR, 6 PT, REGULAR, 12MM	1	K	2	55	
SOCKET, SOCKET WRENCH, 1/4" DR, 6 PT, REGULAR, 13MM	1	K	2	56	
SOCKET, SOCKET WRENCH, 1/4" DR, 6 PT, REGULAR, 14MM	1	K	2	57	
SOCKET, SOCKET WRENCH, 1/4" DR, 6 PT, REGULAR, 15MM	1	K	2	58	
SOCKET, SOCKET WRENCH, 1/2" DR, 12 PT, REGULAR, 25/32"	1	K	2	59	
SOCKET, SOCKET WRENCH, 1/2" DR, 6 PT, REGULAR, 24MM	1	K	2	60	
SOCKET, SOCKET WRENCH, 1/2" DR, 6 PT, REGULAR, 25MM	1	K	2	61	
SOCKET, SOCKET WRENCH, 1/2" DR, 6 PT, REGULAR, 26MM	1	K	2	62	
SOCKET, SOCKET WRENCH, 1/2" DR, 6 PT, REGULAR, 27MM	1	K	2	63	
SOCKET, SOCKET WRENCH, 1/2" DR, 6 PT, REGULAR, 28MM	1	K	2	64	
SOCKET, SOCKET WRENCH, 1/2" DR, 6 PT, REGULAR, 29MM	1	K	2	65	
SOCKET, SOCKET WRENCH, 1/2" DR, 6 PT, REGULAR, 30MM	1	K	2	66	
SOCKET, SOCKET WRENCH, 1/2" DR, 6 PT, REGULAR, 32MM	1	K	2	67	
SOCKET, SOCKET WRENCH, 1/2" DR, 6 PT, REGULAR, 36MM	1	K	2	68	
EXTENSION, 1/2" DR, 10" LONG	1	K	2	69	
SOCKET, SOCKET WRENCH, 1/2" DR, 12 PT, REGULAR, 21/32"	1	K	2	70	
SOCKET, SOCKET WRENCH, 1/2" DR, 6 PT, REGULAR, 23MM	1	K	2	71	
SOCKET, SOCKET WRENCH, 1/2" DR, 6 PT, REGULAR, 22MM	1	K	2	72	
SOCKET, SOCKET WRENCH, 1/2" DR, 6 PT, REGULAR, 21MM	1	K	2	73	

TM 9-4910-783-13&P

SATS BASE TOOL INVENTORY LIST

0058 00

INVENTORY

NOMENCLATURE	QTY	RACK	DRAWER	LOCATION	AMOUNT
SOCKET, SOCKET WRENCH, 1/2" DR, 6 PT, REGULAR, 19MM	1	K	2	74	
SOCKET, SOCKET WRENCH, 1/2" DR, 6 PT, REGULAR, 18MM	1	K	2	75	
SOCKET, SOCKET WRENCH, 1/2" DR, 6 PT, REGULAR, 17MM	1	K	2	76	
SOCKET, SOCKET WRENCH, 1/2" DR, 6 PT, REGULAR, 16MM	1	K	2	77	
SOCKET, SOCKET WRENCH, 1/2" DR, 6 PT, REGULAR, 15MM	1	K	2	78	
SOCKET, SOCKET WRENCH, 1/2" DR, 6 PT, REGULAR, 14MM	1	K	2	79	
SOCKET, SOCKET WRENCH, 1/2" DR, 6 PT, REGULAR, 13MM	1	K	2	80	
SOCKET, SOCKET WRENCH, 1/2" DR, 6 PT, REGULAR, 12MM	1	K	2	81	
SOCKET, SOCKET WRENCH, 1/2" DR, 6 PT, REGULAR, 11MM	1	K	2	82	
SOCKET, SOCKET WRENCH, 1/2" DR, 12 PT, REGULAR, 19/32"	1	K	2	83	
SOCKET, SOCKET WRENCH, 1/2" DR, 6 PT, REGULAR, 9MM	1	K	2	84	
SOCKET, SOCKET WRENCH, 1/2" DR, 6 PT, REGULAR, 10MM	1	K	2	85	
SOCKET, SOCKET WRENCH, 1/2" DR, 12 PT, DEEP, 19MM	1	K	2	86	
SOCKET, SOCKET WRENCH, 1/2" DR, 12 PT, DEEP, 18MM	1	K	2	87	
SOCKET, SOCKET WRENCH, 1/2" DR, 12 PT, DEEP, 17MM	1	K	2	88	
SOCKET, SOCKET WRENCH, 1/2" DR, 12 PT, DEEP, 16MM	1	K	2	89	
SOCKET, SOCKET WRENCH, 1/2" DR, 12 PT, DEEP, 15MM	1	K	2	90	
SOCKET, SOCKET WRENCH, 1/2" DR, 12 PT, DEEP, 14MM	1	K	2	91	
SOCKET, SOCKET WRENCH, 1/2" DR, 12 PT, DEEP, 13MM	1	K	2	92	
SOCKET, SOCKET WRENCH, 1/2" DR, 12 PT, DEEP, 12MM	1	K	2	93	
SOCKET, SOCKET WRENCH, 1/2" DR, 12 PT, DEEP, 11MM	1	K	2	94	
SOCKET, SOCKET WRENCH, 1/2" DR, 12 PT, DEEP, 10MM	1	K	2	95	
EXTENSION, 1/2" DR, 5" LONG	1	K	2	96	
EXTENSION, 1/2" DR, 3" LONG	1	K	2	97	
SOCKET, SOCKET WRENCH, 1/2" DR, 12 PT, DEEP, 20MM	1	K	2	98	
SOCKET, SOCKET WRENCH, 1/2" DR, 12 PT, DEEP, 21MM	1	K	2	99	
SOCKET, SOCKET WRENCH, 1/2" DR, 12 PT, DEEP, 22MM	1	K	2	100	
SOCKET, SOCKET WRENCH, 1/2" DR, 12 PT, DEEP, 23MM	1	K	2	101	
SOCKET, SOCKET WRENCH, 1/2" DR, 12 PT, DEEP, 24MM	1	K	2	102	
SOCKET, SOCKET WRENCH, 1/2" DR, 12 PT, DEEP, 25MM	1	K	2	103	
SOCKET, SOCKET WRENCH, 1/2" DR, 12 PT, DEEP, 26MM	1	K	2	104	
SOCKET, SOCKET WRENCH, 1/2" DR, 12 PT, DEEP, 27MM	1	K	2	105	
SOCKET, SOCKET WRENCH, 1/2" DR, 12 PT, DEEP, 28MM	1	K	2	106	
SOCKET, SOCKET WRENCH, 1/2" DR, 12 PT, DEEP, 29MM	1	K	2	107	
SOCKET, SOCKET WRENCH, 1/2" DR, 12 PT, DEEP, 30MM	1	K	2	108	
SOCKET, SOCKET WRENCH, 1/2" DR, 12 PT, DEEP, 32MM	1	K	2	109	

TM 9-4910-783-13&P

K, 3

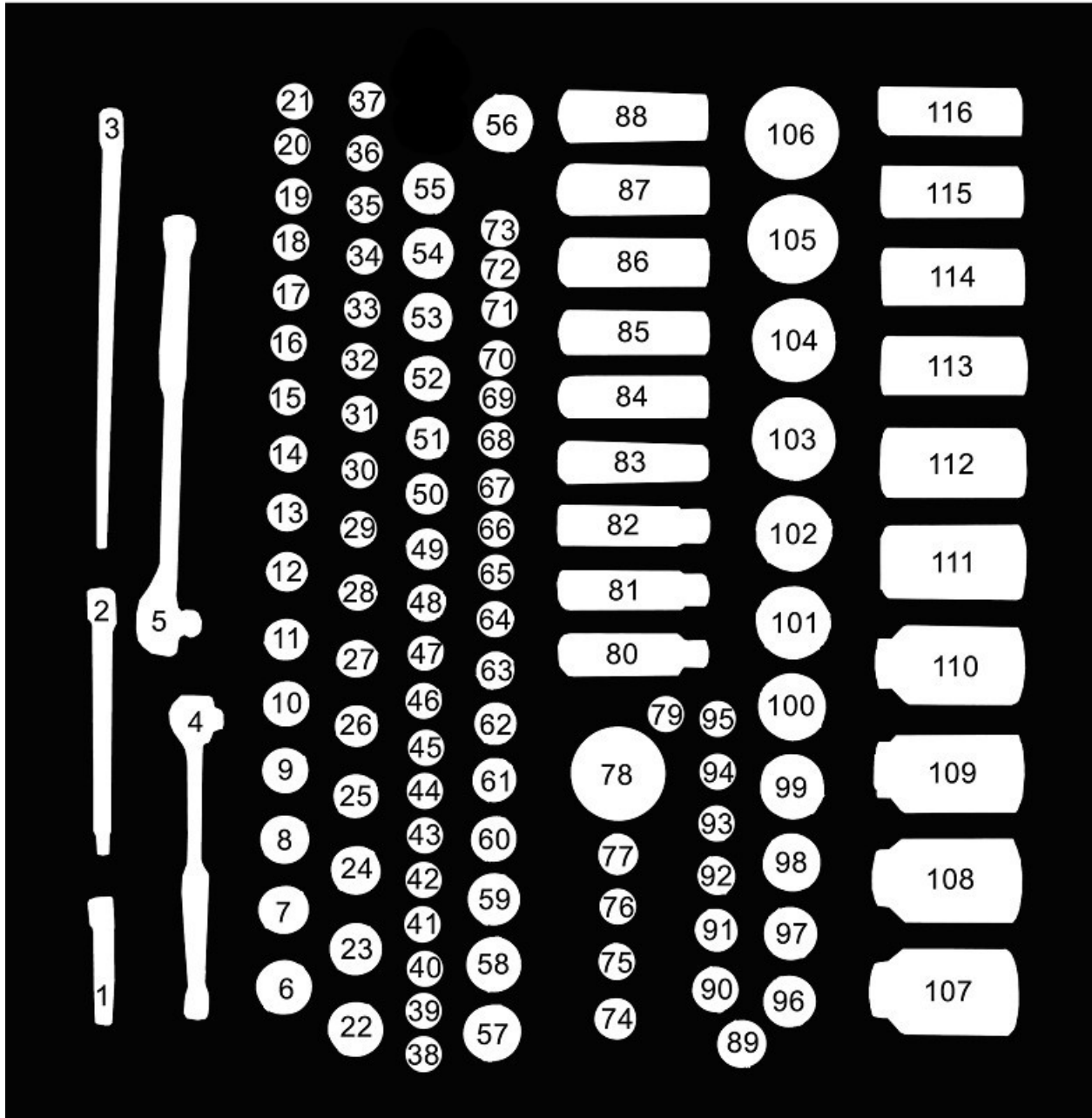

TM 9-4910-783-13&P

SATS BASE TOOL INVENTORY LIST

0058 00

NOMENCLATURE	INVENTORY				AMOUNT
	QTY	RACK	DRAWER	LOCATION	
EXTENSION, 3/8" DR, 3" LONG	1	K	3	1	
EXTENSION, 3/8" DR, 6" LONG	1	K	3	2	
EXTENSION, 3/8" DR, 9.5" LONG	1	K	3	3	
HANDLE, RATCHET, 3/8" DR, 6" LONG	1	K	3	4	
HANDLE, RATCHET, 1/2" DR, 10" LONG	1	K	3	5	
SOCKET, SOCKET WRENCH, 3/8" DR, 6 PT, DEEP, 26MM	1	K	3	6	
SOCKET, SOCKET WRENCH, 3/8" DR, 6 PT, DEEP, 23MM	1	K	3	7	
SOCKET, SOCKET WRENCH, 3/8" DR, 6 PT, DEEP, 22MM	1	K	3	8	
SOCKET, SOCKET WRENCH, 3/8" DR, 6 PT, DEEP, 21MM	1	K	3	9	
SOCKET, SOCKET WRENCH, 3/8" DR, 6 PT, DEEP, 20MM	1	K	3	10	
SOCKET, SOCKET WRENCH, 3/8" DR, 6 PT, DEEP, 19MM	1	K	3	11	
SOCKET, SOCKET WRENCH, 3/8" DR, 6 PT, DEEP, 18MM	1	K	3	12	
SOCKET, SOCKET WRENCH, 3/8" DR, 6 PT, DEEP, 17MM	1	K	3	13	
SOCKET, SOCKET WRENCH, 3/8" DR, 6 PT, DEEP, 16MM	1	K	3	14	
SOCKET, SOCKET WRENCH, 3/8" DR, 6 PT, DEEP, 15MM	1	K	3	15	
SOCKET, SOCKET WRENCH, 3/8" DR, 6 PT, DEEP, 14MM	1	K	3	16	
SOCKET, SOCKET WRENCH, 3/8" DR, 6 PT, DEEP, 13MM	1	K	3	17	
SOCKET, SOCKET WRENCH, 3/8" DR, 6 PT, DEEP, 12MM	1	K	3	18	
SOCKET, SOCKET WRENCH, 3/8" DR, 6 PT, DEEP, 11MM	1	K	3	19	
SOCKET, SOCKET WRENCH, 3/8" DR, 6 PT, DEEP, 10MM	1	K	3	20	
SOCKET, SOCKET WRENCH, 3/8" DR, 6 PT, DEEP, 9MM	1	K	3	21	
SOCKET, SOCKET WRENCH, 3/8" DR, 6 PT, DEEP, 1"	1	K	3	22	
SOCKET, SOCKET WRENCH, 3/8" DR, 6 PT, DEEP, 15/16"	1	K	3	23	
SOCKET, SOCKET WRENCH, 3/8" DR, 6 PT, DEEP, 7/8"	1	K	3	24	
SOCKET, SOCKET WRENCH, 3/8" DR, 6 PT, DEEP, 13/16"	1	K	3	25	
SOCKET, SOCKET WRENCH, 3/8" DR, 6 PT, DEEP, 3/4"	1	K	3	26	
SOCKET, SOCKET WRENCH, 3/8" DR, 6 PT, DEEP, 11/16"	1	K	3	27	
SOCKET, SOCKET WRENCH, 3/8" DR, 6 PT, DEEP, 5/8"	1	K	3	28	
SOCKET, SOCKET WRENCH, 3/8" DR, 6 PT, DEEP, 9/16"	1	K	3	29	
SOCKET, SOCKET WRENCH, 3/8" DR, 6 PT, DEEP, 1/2"	1	K	3	30	
SOCKET, SOCKET WRENCH, 3/8" DR, 6 PT, DEEP, 7/16"	1	K	3	31	
SOCKET, SOCKET WRENCH, 3/8" DR, 6 PT, DEEP, 3/8"	1	K	3	32	
SOCKET, SOCKET WRENCH, 3/8" DR, 6 PT, DEEP, 5/16"	1	K	3	33	
SOCKET, SOCKET WRENCH, 3/8" DR, 6 PT, DEEP, 1/4"	1	K	3	34	
SOCKET, SOCKET WRENCH, 3/8" DR, 6 PT, DEEP, 6MM	1	K	3	35	
SOCKET, SOCKET WRENCH, 3/8" DR, 6 PT, DEEP, 7MM	1	K	3	36	

TM 9-4910-783-13&P

SATS BASE TOOL INVENTORY LIST

0058 00

NOMENCLATURE	INVENTORY				AMOUNT
	QTY	RACK	DRAWER	LOCATION	
SOCKET, SOCKET WRENCH, 3/8" DR, 6 PT, DEEP, 8MM	1	K	3	37	
SOCKET, SOCKET WRENCH, 3/8" DR, 6 PT, REGULAR, 6MM	1	K	3	38	
SOCKET, SOCKET WRENCH, 3/8" DR, 6 PT, REGULAR, 7MM	1	K	3	39	
SOCKET, SOCKET WRENCH, 3/8" DR, 6 PT, REGULAR, 8MM	1	K	3	40	
SOCKET, SOCKET WRENCH, 3/8" DR, 6 PT, REGULAR, 9MM	1	K	3	41	
SOCKET, SOCKET WRENCH, 3/8" DR, 6 PT, REGULAR, 10MM	1	K	3	42	
SOCKET, SOCKET WRENCH, 3/8" DR, 6 PT, REGULAR, 11MM	1	K	3	43	
SOCKET, SOCKET WRENCH, 3/8" DR, 6 PT, REGULAR, 12MM	1	K	3	44	
SOCKET, SOCKET WRENCH, 3/8" DR, 6 PT, REGULAR, 13MM	1	K	3	45	
SOCKET, SOCKET WRENCH, 3/8" DR, 6 PT, REGULAR, 14MM	1	K	3	46	
SOCKET, SOCKET WRENCH, 3/8" DR, 6 PT, REGULAR, 15MM	1	K	3	47	
SOCKET, SOCKET WRENCH, 3/8" DR, 6 PT, REGULAR, 16MM	1	K	3	48	
SOCKET, SOCKET WRENCH, 3/8" DR, 6 PT, REGULAR, 17MM	1	K	3	49	
SOCKET, SOCKET WRENCH, 3/8" DR, 6 PT, REGULAR, 18MM	1	K	3	50	
SOCKET, SOCKET WRENCH, 3/8" DR, 6 PT, REGULAR, 19MM	1	K	3	51	
SOCKET, SOCKET WRENCH, 3/8" DR, 6 PT, REGULAR, 20MM	1	K	3	52	
SOCKET, SOCKET WRENCH, 3/8" DR, 6 PT, REGULAR, 21MM	1	K	3	53	
SOCKET, SOCKET WRENCH, 3/8" DR, 6 PT, REGULAR, 22MM	1	K	3	54	
SOCKET, SOCKET WRENCH, 3/8" DR, 6 PT, REGULAR, 23MM	1	K	3	55	
SOCKET, SOCKET WRENCH, 3/8" DR, 6 PT, REGULAR, 26MM	1	K	3	56	
SOCKET, SOCKET WRENCH, 3/8" DR, 6 PT, REGULAR, 1"	1	K	3	57	
SOCKET, SOCKET WRENCH, 3/8" DR, 6 PT, REGULAR, 15/16"	1	K	3	58	
SOCKET, SOCKET WRENCH, 3/8" DR, 6 PT, REGULAR, 7/8"	1	K	3	59	
SOCKET, SOCKET WRENCH, 3/8" DR, 6 PT, REGULAR, 13/16"	1	K	3	60	
SOCKET, SOCKET WRENCH, 3/8" DR, 6 PT, REGULAR, 3/4"	1	K	3	61	
SOCKET, SOCKET WRENCH, 3/8" DR, 6 PT, REGULAR, 11/16"	1	K	3	62	
SOCKET, SOCKET WRENCH, 3/8" DR, 6 PT, REGULAR, 5/8"	1	K	3	63	
SOCKET, SOCKET WRENCH, 3/8" DR, 6 PT, REGULAR, 9/16"	1	K	3	64	
SOCKET, SOCKET WRENCH, 3/8" DR, 6 PT, REGULAR, 1/2"	1	K	3	65	
SOCKET, SOCKET WRENCH, 3/8" DR, 6 PT, REGULAR, 7/16"	1	K	3	66	
SOCKET, SOCKET WRENCH, 3/8" DR, 6 PT, REGULAR, 3/8"	1	K	3	67	
SOCKET, SOCKET WRENCH, 3/8" DR, 6 PT, REGULAR, 5/16"	1	K	3	68	
SOCKET, SOCKET WRENCH, 3/8" DR, 6 PT, REGULAR, 1/4"	1	K	3	69	
ADAPTER, SOCKET WRENCH DRIVE, 1/4" MALE - 3/8" FEMALE	1	K	3	70	
ADAPTER, SOCKET WRENCH DRIVE, 1/2" MALE - 3/8" FEMALE	1	K	3	71	
EXTENSION, 3/8" DR, 2" LONG	1	K	3	72	
JOINT, UNIVERSAL, 3/8"DR	1	K	3	73	

TM 9-4910-783-13&P

SATS BASE TOOL INVENTORY LIST

0058 00

NOMENCLATURE	QTY	RACK	DRAWER	LOCATION	INVENTORY
					AMOUNT
ADAPTER, SOCKET WRENCH DRIVE, 3/4" MALE - 1/2" FEMALE	1	K	3	74	
ADAPTER, SOCKET WRENCH DRIVE, 3/8" MALE - 1/2" FEMALE	1	K	3	75	
EXTENSION, 1/2" DR, 2" LONG	1	K	3	76	
JOINT, UNIVERSAL, 1/2" DR	1	K	3	77	
STUD REMOVER, 5/16" - 3/4" CAPACITY	1	K	3	78	
SOCKET, SOCKET WRENCH, 1/2" DR, 6 PT, REGULAR, 3/8"	1	K	3	79	
SOCKET, SOCKET WRENCH, 1/2" DR, 6 PT, DEEP, 3/8"	1	K	3	80	
SOCKET, SOCKET WRENCH, 1/2" DR, 6 PT, DEEP, 7/16"	1	K	3	81	
SOCKET, SOCKET WRENCH, 1/2" DR, 6 PT, DEEP, 1/2"	1	K	3	82	
SOCKET, SOCKET WRENCH, 1/2" DR, 6 PT, DEEP, 9/16"	1	K	3	83	
SOCKET, SOCKET WRENCH, 1/2" DR, 6 PT, DEEP, 5/8"	1	K	3	84	
SOCKET, SOCKET WRENCH, 1/2" DR, 6 PT, DEEP, 11/16"	1	K	3	85	
SOCKET, SOCKET WRENCH, 1/2" DR, 6 PT, DEEP, 3/4"	1	K	3	86	
SOCKET, SOCKET WRENCH, 1/2" DR, 6 PT, DEEP, 13/16"	1	K	3	87	
SOCKET, SOCKET WRENCH, 1/2" DR, 6 PT, DEEP, 7/8"	1	K	3	88	
SOCKET, SOCKET WRENCH, 1/2" DR, 6 PT, REGULAR, 13/16"	1	K	3	89	
SOCKET, SOCKET WRENCH, 1/2" DR, 6 PT, REGULAR, 3/4"	1	K	3	90	
SOCKET, SOCKET WRENCH, 1/2" DR, 6 PT, REGULAR, 11/16"	1	K	3	91	
SOCKET, SOCKET WRENCH, 1/2" DR, 6 PT, REGULAR, 5/8"	1	K	3	92	
SOCKET, SOCKET WRENCH, 1/2" DR, 6 PT, REGULAR, 9/16"	1	K	3	93	
SOCKET, SOCKET WRENCH, 1/2" DR, 6 PT, REGULAR, 1/2"	1	K	3	94	
SOCKET, SOCKET WRENCH, 1/2" DR, 6 PT, REGULAR, 7/16"	1	K	3	95	
SOCKET, SOCKET WRENCH, 1/2" DR, 6 PT, REGULAR, 7/8"	1	K	3	96	
SOCKET, SOCKET WRENCH, 1/2" DR, 6 PT, REGULAR, 15/16"	1	K	3	97	
SOCKET, SOCKET WRENCH, 1/2" DR, 6 PT, REGULAR, 1"	1	K	3	98	
SOCKET, SOCKET WRENCH, 1/2" DR, 6 PT, REGULAR, 1-1/16"	1	K	3	99	
SOCKET, SOCKET WRENCH, 1/2" DR, 6 PT, REGULAR, 1-1/8"	1	K	3	100	
SOCKET, SOCKET WRENCH, 1/2" DR, 6 PT, REGULAR, 1-3/16"	1	K	3	101	
SOCKET, SOCKET WRENCH, 1/2" DR, 6 PT, REGULAR, 1-1/4"	1	K	3	102	
SOCKET, SOCKET WRENCH, 1/2" DR, 6 PT, REGULAR, 1-5/16"	1	K	3	103	
SOCKET, SOCKET WRENCH, 1/2" DR, 6 PT, REGULAR, 1-3/8"	1	K	3	104	
SOCKET, SOCKET WRENCH, 1/2" DR, 6 PT, REGULAR, 1-7/16"	1	K	3	105	
SOCKET, SOCKET WRENCH, 1/2" DR, 6 PT, REGULAR, 1-1/2"	1	K	3	106	
SOCKET, SOCKET WRENCH, 1/2" DR, 6 PT, DEEP, 1-1/2"	1	K	3	107	
SOCKET, SOCKET WRENCH, 1/2" DR, 6 PT, DEEP, 1-7/16"	1	K	3	108	
SOCKET, SOCKET WRENCH, 1/2" DR, 6 PT, DEEP, 1-3/8"	1	K	3	109	

TM 9-4910-783-13&P

SATS BASE TOOL INVENTORY LIST

0058 00

NOMENCLATURE	INVENTORY				
	QTY	RACK	DRAWER	LOCATION	AMOUNT
SOCKET, SOCKET WRENCH, 1/2" DR, 6 PT, DEEP, 1-5/16"	1	K	3	110	
SOCKET, SOCKET WRENCH, 1/2" DR, 6 PT, DEEP, 1-1/4"	1	K	3	111	
SOCKET, SOCKET WRENCH, 1/2" DR, 6 PT, DEEP, 1-3/16"	1	K	3	112	
SOCKET, SOCKET WRENCH, 1/2" DR, 6 PT, DEEP, 1-1/8"	1	K	3	113	
SOCKET, SOCKET WRENCH, 1/2" DR, 6 PT, DEEP, 1-1/16"	1	K	3	114	
SOCKET, SOCKET WRENCH, 1/2" DR, 6 PT, DEEP, 1"	1	K	3	115	
SOCKET, SOCKET WRENCH, 1/2" DR, 6 PT, DEEP, 15/16"	1	K	3	116	

TM 9-4910-783-13&P

SATS BASE TOOL INVENTORY LIST

0058 00

INVENTORY

NOMENCLATURE	QTY	RACK	DRAWER	LOCATION	AMOUNT
DRILL, BATTERY, RECHARGEABLE, RIGHT ANGLE, 3/8"	1	K	4	1	
SHARPENER, DRILL, PORTABLE	1	K	4	2	
ACCESSORIES, DRILL SHARPENER	1	K	4	3	
ACCESSORIES, DRILL SHARPENER	1	K	4	4	
ACCESSORIES, DRILL SHARPENER	1	K	4	5	

K, 4

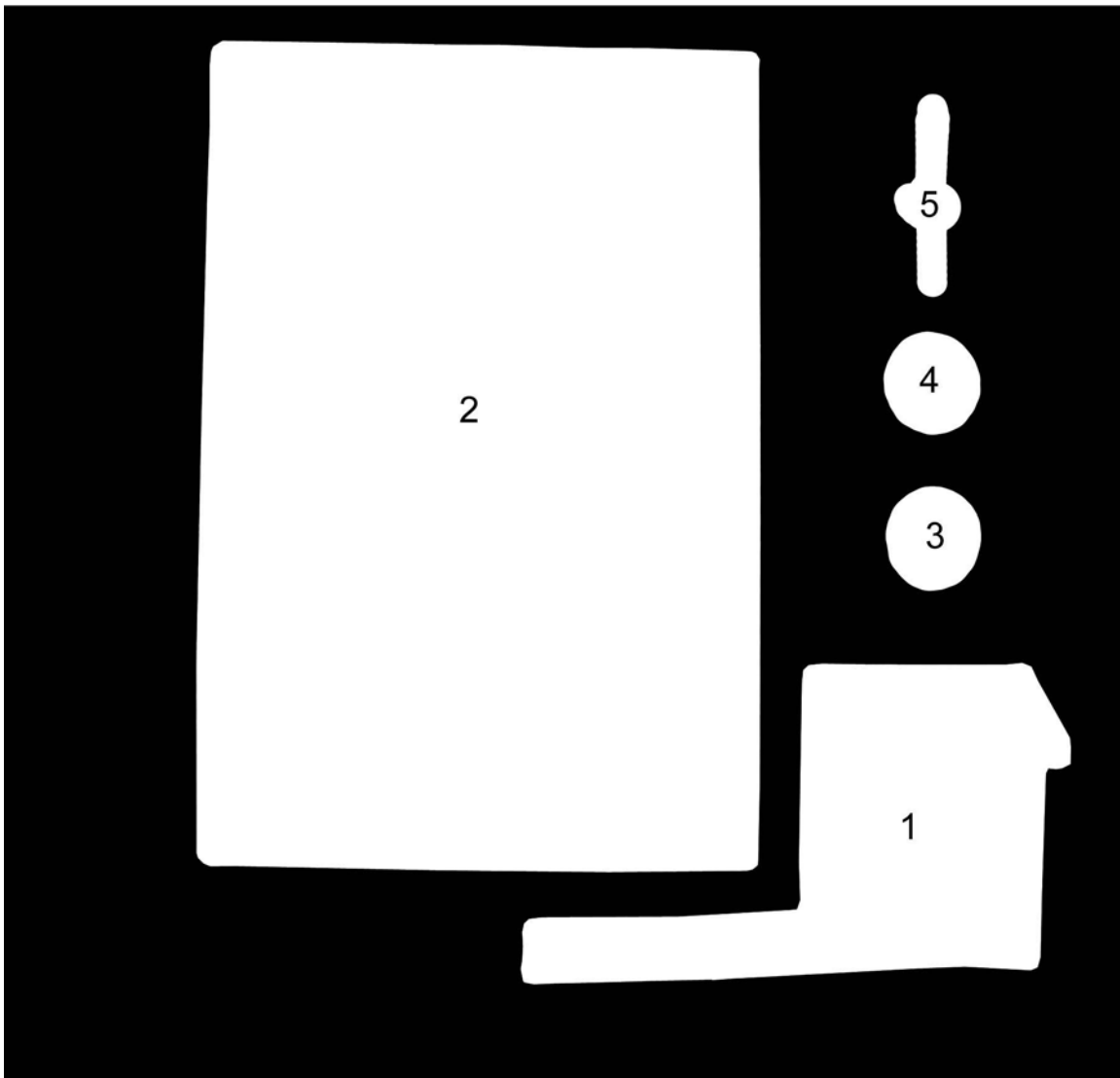

TM 9-4910-783-13&P

SATS BASE TOOL INVENTORY LIST

0058 00

NOMENCLATURE	QTY	RACK	DRAWER	LOCATION	INVENTORY AMOUNT
DRILL SET, TWIST	1	K	5	3	
DRILL SET, TWIST, LEFT HAND	1	K	5	4	
EXTRACTOR SET, SCREW	1	K	5	5	
DRILL-DRIVER, BATTERY OPERATED, RECHARGEABLE, 18V 1/2"	1	K	5	6	
SPLITTING TOOL, NUT	1	K	5	7	
EXTRACTOR SET, HARDENED SCREW	1	K	5	1, 2	

K, 5

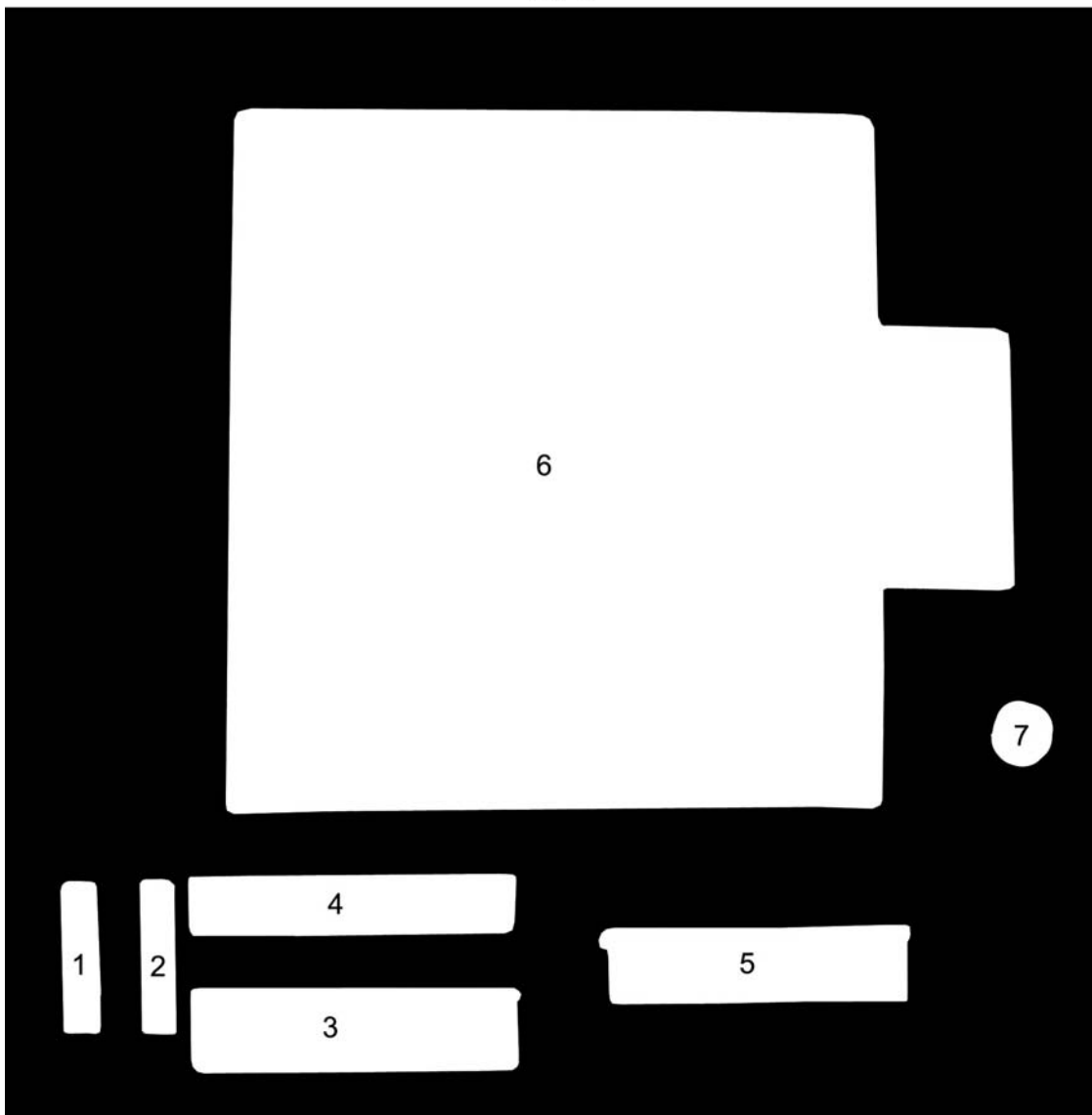

TM 9-4910-783-13&P

SATS BASE TOOL INVENTORY LIST

0058 00

INVENTORY

NOMENCLATURE	QTY	RACK	DRAWER	LOCATION	AMOUNT
DRILL, ELECTRIC, PORTABLE, RIGHT ANGLE, 1/2"	1	K	6	1	
DRILL, ELECTRIC, PORTABLE, RIGHT ANGLE, 3/8"	1	K	6	2	
SANDER/GRINDER, 4-1/2"	1	K	6	3	
DRILL- DRIVER, ELECTRIC, 1/2"	1	K	6	4	
ACCESSORIES, DRILL AND SANDER	1	K	6	5	
ACCESSORIES, DRILL AND SANDER	1	K	6	6	
ACCESSORIES, DRILL AND SANDER	1	K	6	7	
ACCESSORIES, DRILL AND SANDER	1	K	6	8	
ACCESSORIES, DRILL AND SANDER	1	K	6	9	

K, 6

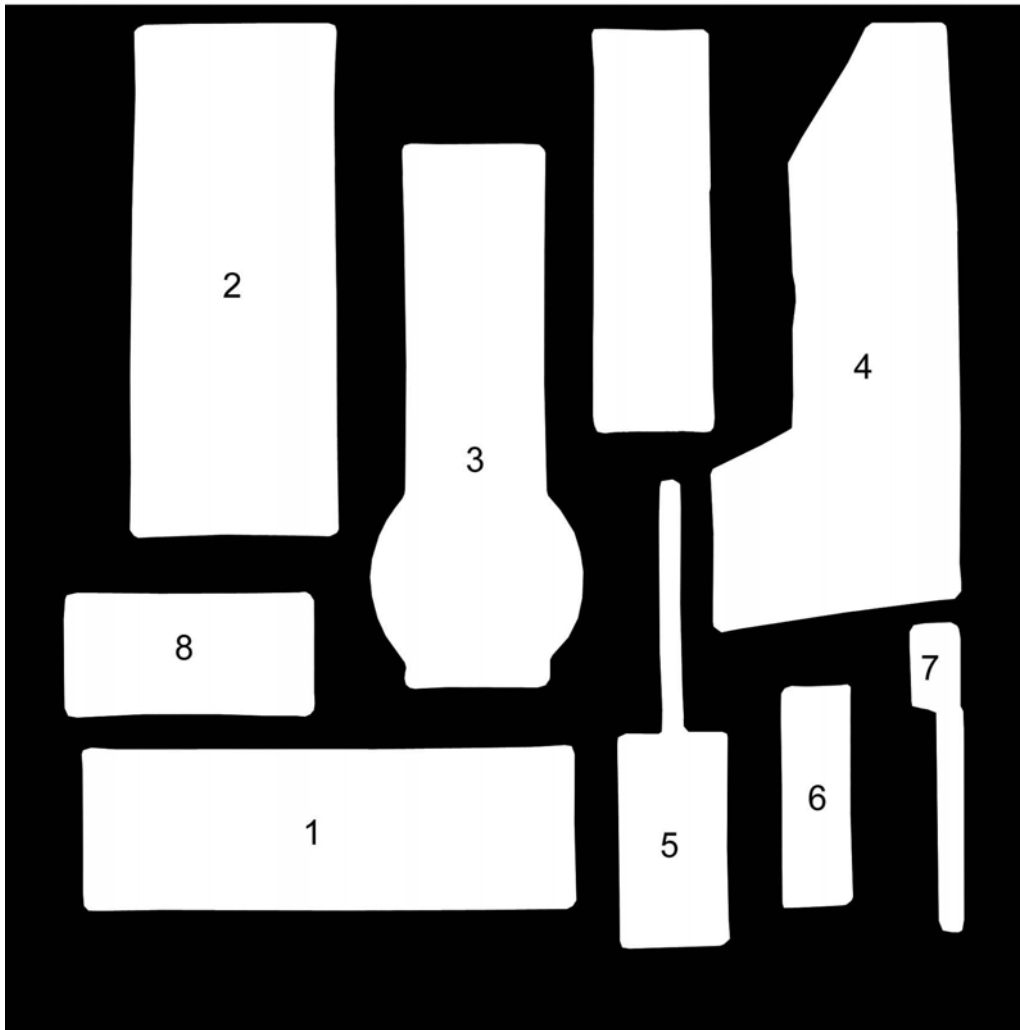

TM 9-4910-783-13&P

SATS BASE TOOL INVENTORY LIST

0058 00

INVENTORY

NOMENCLATURE	QTY	RACK	DRAWER	LOCATION	AMOUNT
DRILL, PNEUMATIC, RIGHT ANGLE	1	K	7	2	
HAMMER, PNEUMATIC	1	K	7	3	
WRENCH KIT, RATCHET, PNEUMATIC	1	K	7	1, 4	

K, 7

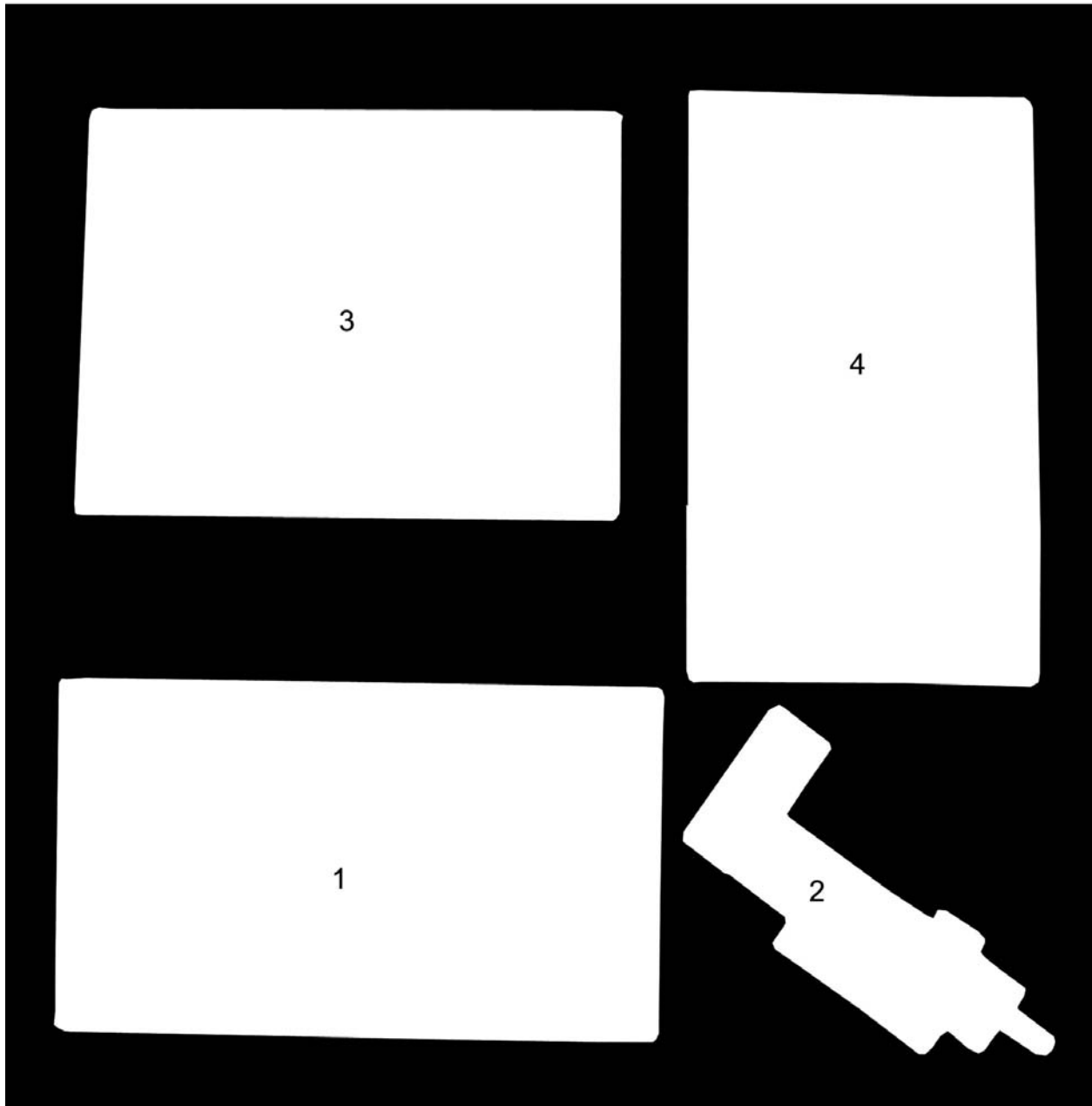

TM 9-4910-783-13&P

SATS BASE TOOL INVENTORY LIST

0058 00

INVENTORY

NOMENCLATURE	QTY	RACK	DRAWER	LOCATION	AMOUNT
TOOL KIT, CUTTING, ABRASIVE, PNEUMATIC	1	K	8	1	
PUNCH SET, CUTTING, DOUBLE BOW, GASKET	1	K	8	2	
SHEARS, BENT, TRIMMER	1	K	8	4	
DRESSER, ABRASIVE WHEEL	1	K	8	5	
BLADE, ABRASIVE, WHEEL	1	K	8	6	
WHEEL, ABRASIVE, TYPE 29 (PROTOTYPE)	1	K	8	7	
WHEEL, ABRASIVE, TYPE 27	1	K	8	8	
WHEEL, ABRASIVE, FINE, 36 GRIT (PROTOTYPE)	1	K	8	9	
WHEEL, ABRASIVE, COARSE, 90 GRIT (PROTOTYPE)	1	K	8	10	
CAPS, VISE JAW	1	K	8	12, 13	
SCRAPER, GASKET	1	K	8	3, 11	

K, 8

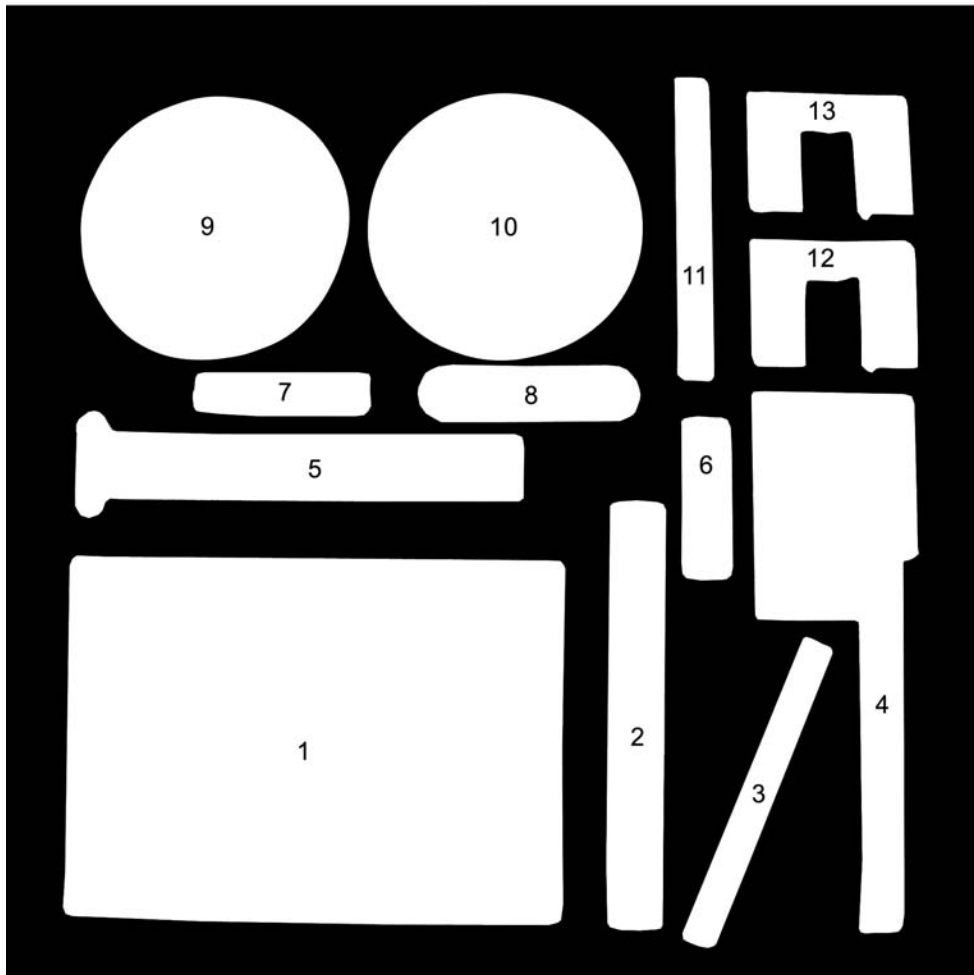

TM 9-4910-783-13&P

SATS BASE TOOL INVENTORY LIST

0058 00

INVENTORY

NOMENCLATURE	QTY	RACK	DRAWER	LOCATION	AMOUNT
FACE SHIELD, INDUSTRIAL	1	K	9	1	
GOGGLES, INDUSTRIAL	1	K	9	2	
APRON, UTILITY	1	K	9	5	
GLOVES, RUBBER, INDUSTRIAL	1	K	9	7	
INFLATOR-GAGE AND HOSE ASSEMBLY, PNEUMATIC TIRE	1	K	9	6	
BLOW GUN, AIR	1	K	9	3, 4	

K, 9

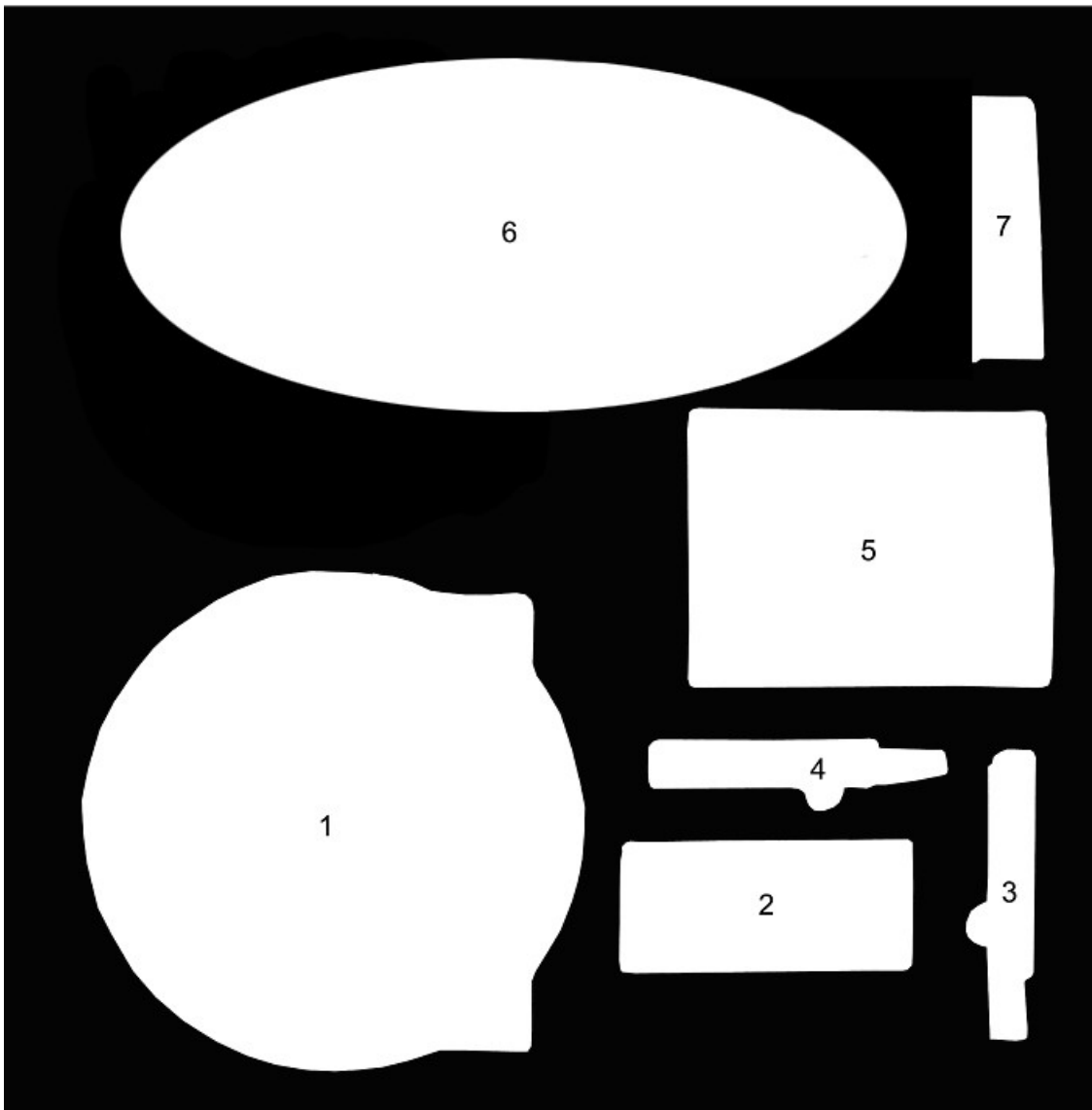

TM 9-4910-783-13&P

SATS BASE TOOL INVENTORY LIST

0058 00

THIS PAGE INTENTIONALLY LEFT BLANK

TM 9-4910-783-13&P

SATS BASE TOOL INVENTORY LIST

0058 00

L,1

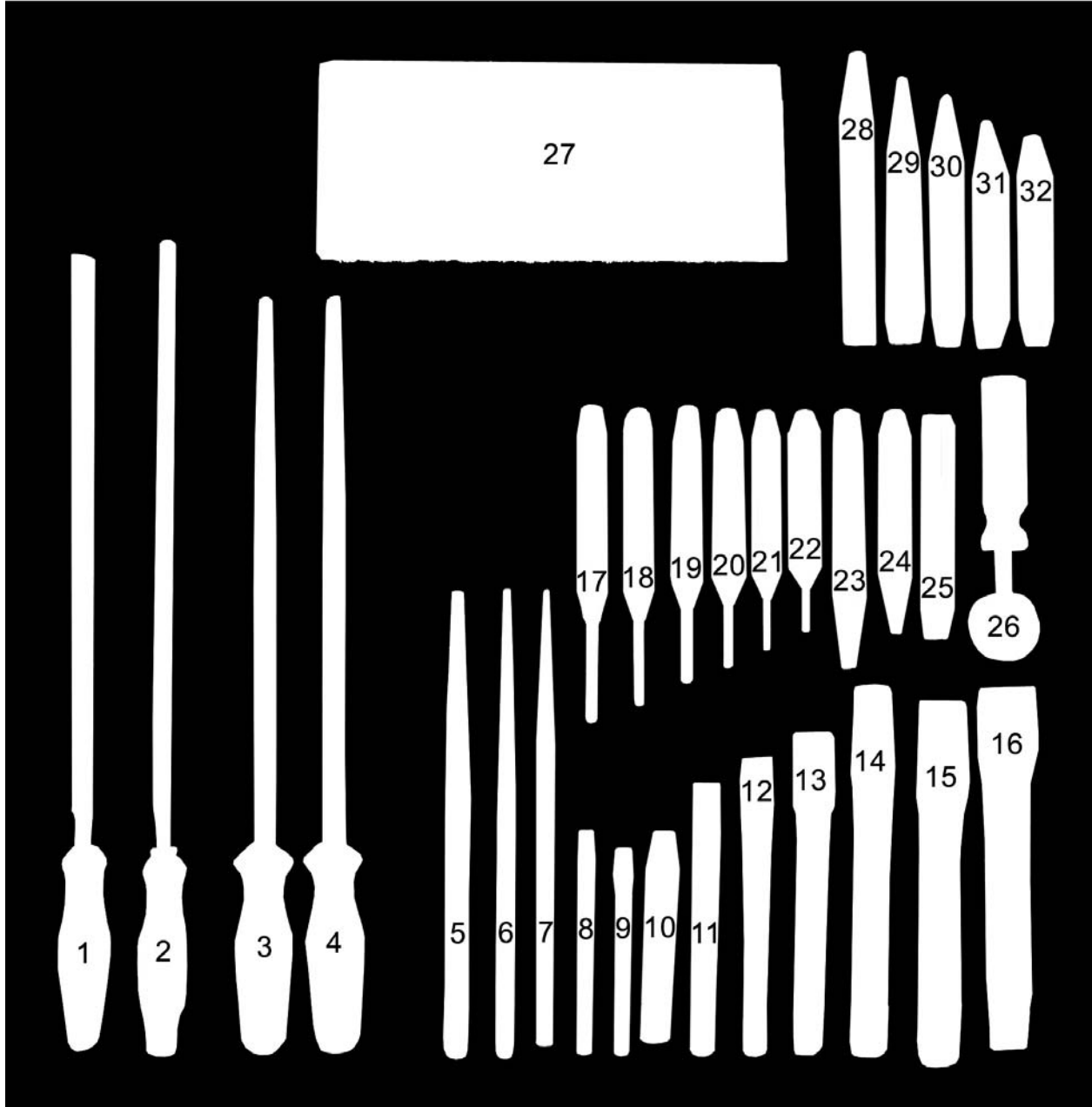

TM 9-4910-783-13&P

SATS BASE TOOL INVENTORY LIST

0058 00

INVENTORY

NOMENCLATURE	QTY	RACK	DRAWER	LOCATION	AMOUNT
FILE SET, HAND, HALF RD, AMER, BAS, 12"	1	L	1	1	
FILE SET, HAND, HALF RD, AMER, BAS, 12"	1	L	1	2	
FILE SET, HAND, 1/2" RD AMER BAS, 12"	1	L	1	3	
FILE SET, HAND, 1/2" RD AMER BAS, 12"	1	L	1	4	
PUNCH AND CHISEL SET, PUNCH, 1/2" DIA, 1/4" PT	1	L	1	5	
PUNCH AND CHISEL SET, PUNCH, 3/8" DIA, 3/16" PT	1	L	1	6	
PUNCH AND CHISEL SET, PUNCH, 5/16" DIA, 1/8" PT	1	L	1	7	
PUNCH AND CHISEL SET, CHISEL, 3/16" DIA, 1/4"	1	L	1	8	
PUNCH AND CHISEL SET, CHISEL, 1/4" DIA, 5/16"	1	L	1	9	
PUNCH AND CHISEL SET, CHISEL, 5/16" DIA, 3/8"	1	L	1	10	
PUNCH AND CHISEL SET, CHISEL, 7/16" DIA, 1/2"	1	L	1	11	
PUNCH AND CHISEL SET, CHISEL, 1/2" DIA, 5/8"	1	L	1	12	
PUNCH AND CHISEL SET, CHISEL, 5/8" DIA, 3/4"	1	L	1	13	
PUNCH AND CHISEL SET, CHISEL, 3/4" DIA, 7/8"	1	L	1	14	
PUNCH AND CHISEL SET, CHISEL, 7/8" DIA, 1"	1	L	1	15	
PUNCH AND CHISEL SET, CHISEL, 1" DIA, 1-3/16"	1	L	1	16	
PUNCH AND CHISEL SET, PUNCH, 1/2", 1/4" PT	1	L	1	17	
PUNCH AND CHISEL SET, PUNCH, 7/16", 7/32" PT	1	L	1	18	
PUNCH AND CHISEL SET, PUNCH, 3/8", 3/16" PT	1	L	1	19	
PUNCH AND CHISEL SET, PUNCH, 5/16", 5/32" PT	1	L	1	20	
PUNCH AND CHISEL SET, PUNCH, 5/16", 1/8" PT	1	L	1	21	
PUNCH AND CHISEL SET, PUNCH, 1/4", 3/32" PT	1	L	1	22	
PUNCH AND CHISEL SET, PUNCH, 1/2"	1	L	1	23	
PUNCH AND CHISEL SET, PUNCH, 3/8"	1	L	1	24	
PUNCH AND CHISEL SET, PUNCH, 5/16"	1	L	1	25	
PUNCH, CHISEL, HOLDER	1	L	1	26	
FILE THREAD RESTORER KIT	1	L	1	27	
PUNCH AND CHISEL SET, PUNCH, 1/2" DIA, 1/4" PT	1	L	1	28	
PUNCH AND CHISEL SET, PUNCH, 7/16" DIA, 7/32" PT	1	L	1	29	
PUNCH AND CHISEL SET, PUNCH, 3/8" DIA, 3/16" PT	1	L	1	30	
PUNCH AND CHISEL SET, PUNCH, 5/16" DIA, 1/8" PT	1	L	1	31	
PUNCH AND CHISEL SET, PUNCH, 1/4" DIA, 3/32" PT	1	L	1	32	

TM 9-4910-783-13&P

SATS BASE TOOL INVENTORY LIST

0058 00

NOMENCLATURE	INVENTORY				
	QTY	RACK	DRAWER	LOCATION	AMOUNT
SCALE, WEIGHING	1	L	2	1	
FINGER, MECHANICAL	1	L	2	3	
BAR, WRECKING	1	L	2	4	
SAW, HAND, CROSSCUT	1	L	2	6	
BAR, PINCH, 26"	1	L	2	2,5	

L,2

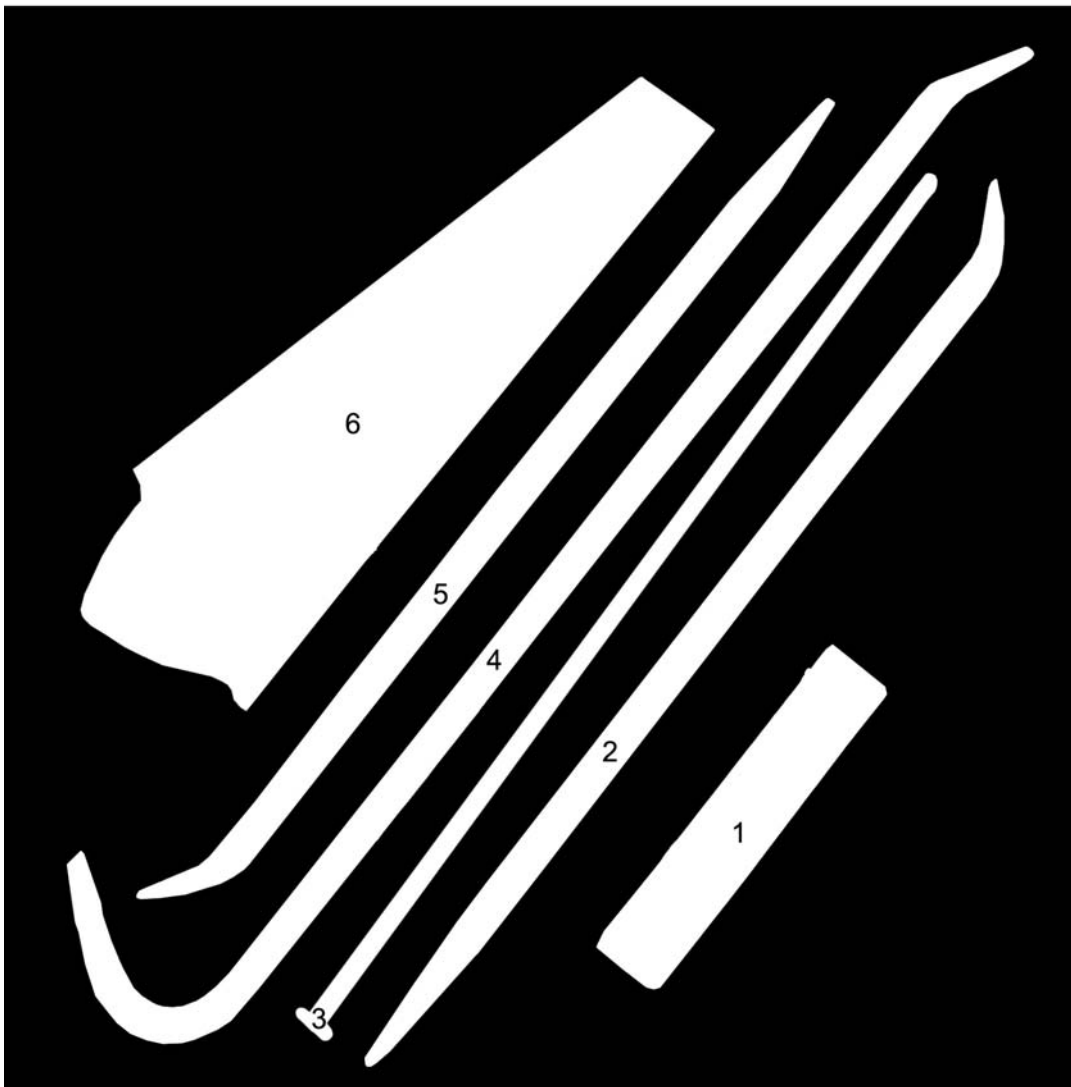

TM 9-4910-783-13&P

SATS BASE TOOL INVENTORY LIST

0058 00

INVENTORY

NOMENCLATURE	QTY	RACK	DRAWER	LOCATION	AMOUNT
HAMMER, SOFT FACE, 2", WITH TIPS TOUGH, EXTRA TOUGH	1	L	3	2	
HAMMER, HAND, SOFT FACE, DEAD BLOW, 10 OZ	1	L	3	1, 6	
HAMMER, HAND, CARPENTER'S, CURVED CLAW, 16 OZ	1	L	3	3, 9	
HAMMER, HAND, SOFT FACE, DEAD BLOW, 52 OZ	1	L	3	4, 5	
HAMMER, HAND, DEAD BLOW, BALL PEEN, 40 OZ	1	L	3	7, 8	
HAMMER, HAND, SOFT FACE, DEAD BLOW, 1-1/2"	1	L	3	10	

L,3

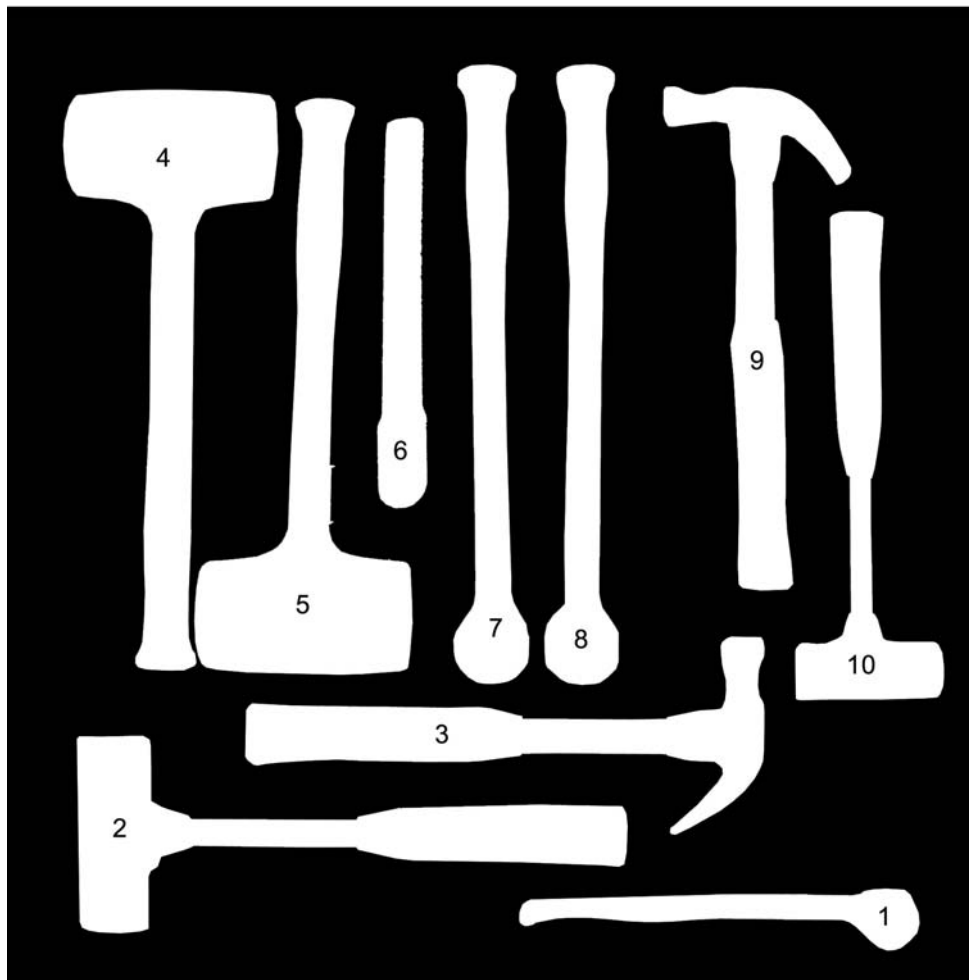

TM 9-4910-783-13&P

SATS BASE TOOL INVENTORY LIST

0058 00

NOMENCLATURE	QTY	RACK	DRAWER	LOCATION	INVENTORY AMOUNT
BLADE, HACKSAW, HAND	1	L	4	1	
CUTTING AND FLARING KIT, TUBE	1	L	4	2	
SAW, HAND, METAL CUTTING, CLOSE QUARTERS	1	L	4	3	
SAW, HAND, METAL CUTTING, CLOSE QUARTERS	1	L	4	4	
BENDER SET, TUBE, HAND ACTUATED, 5/8" OD	1	L	4	5	
BENDER SET, TUBE, HAND ACTUATED, 1/2" OD	1	L	4	6	
BENDER SET, TUBE, HAND ACTUATED, 7/16" OD	1	L	4	7	
BENDER SET, TUBE, HAND ACTUATED, 3/8" OD	1	L	4	8	
BENDER SET, TUBE, HAND ACTUATED, 5/16" OD	1	L	4	9	
BENDER SET, TUBE, HAND ACTUATED, 1/4" OD	1	L	4	10	
SAW, HAND, METAL CUTTING	1	L	4	11	
SAW, HAND, METAL CUTTING	1	L	4	12	

L,4

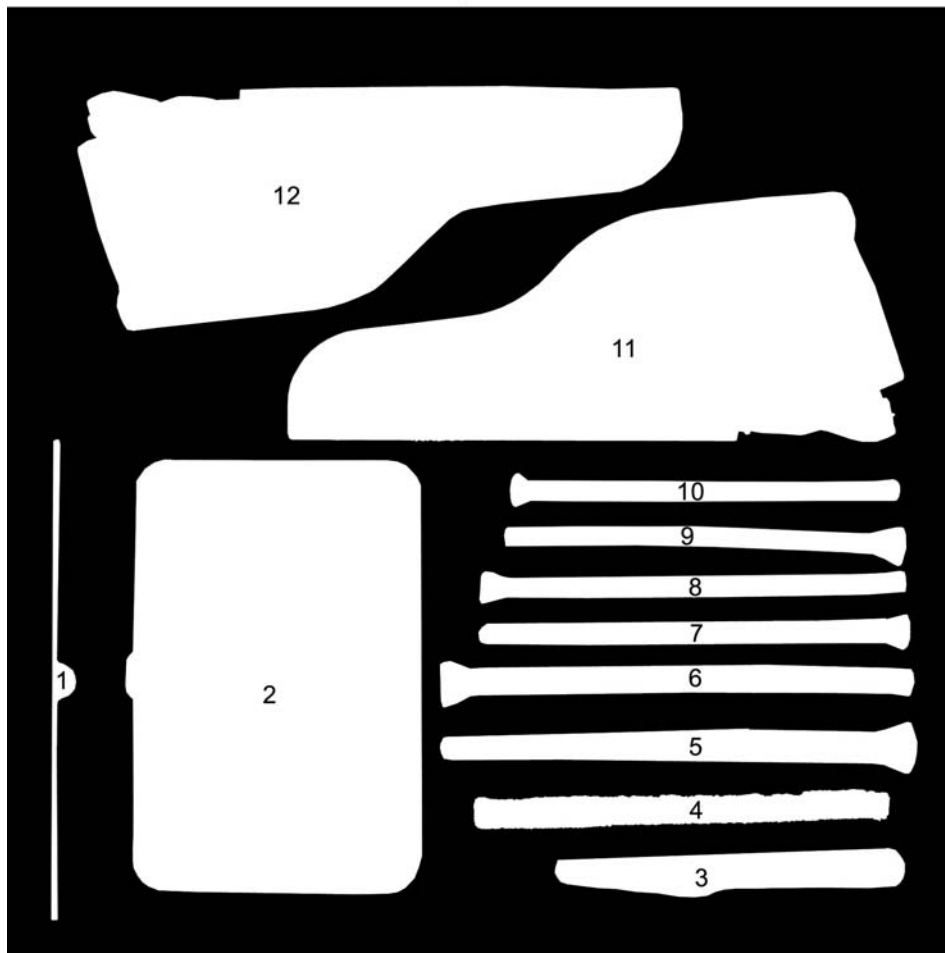

TM 9-4910-783-13&P

SATS BASE TOOL INVENTORY LIST

0058 00

INVENTORY

NOMENCLATURE	QTY	RACK	DRAWER	LOCATION	AMOUNT
CUTTER, BOLT, REPLACEMENT HEAD	1	L	5	1	
CUTTER, BOLT, LIGHTWEIGHT, 24"	1	L	5	3	
CLAMP, C	1	L	5	2, 4	

L,5

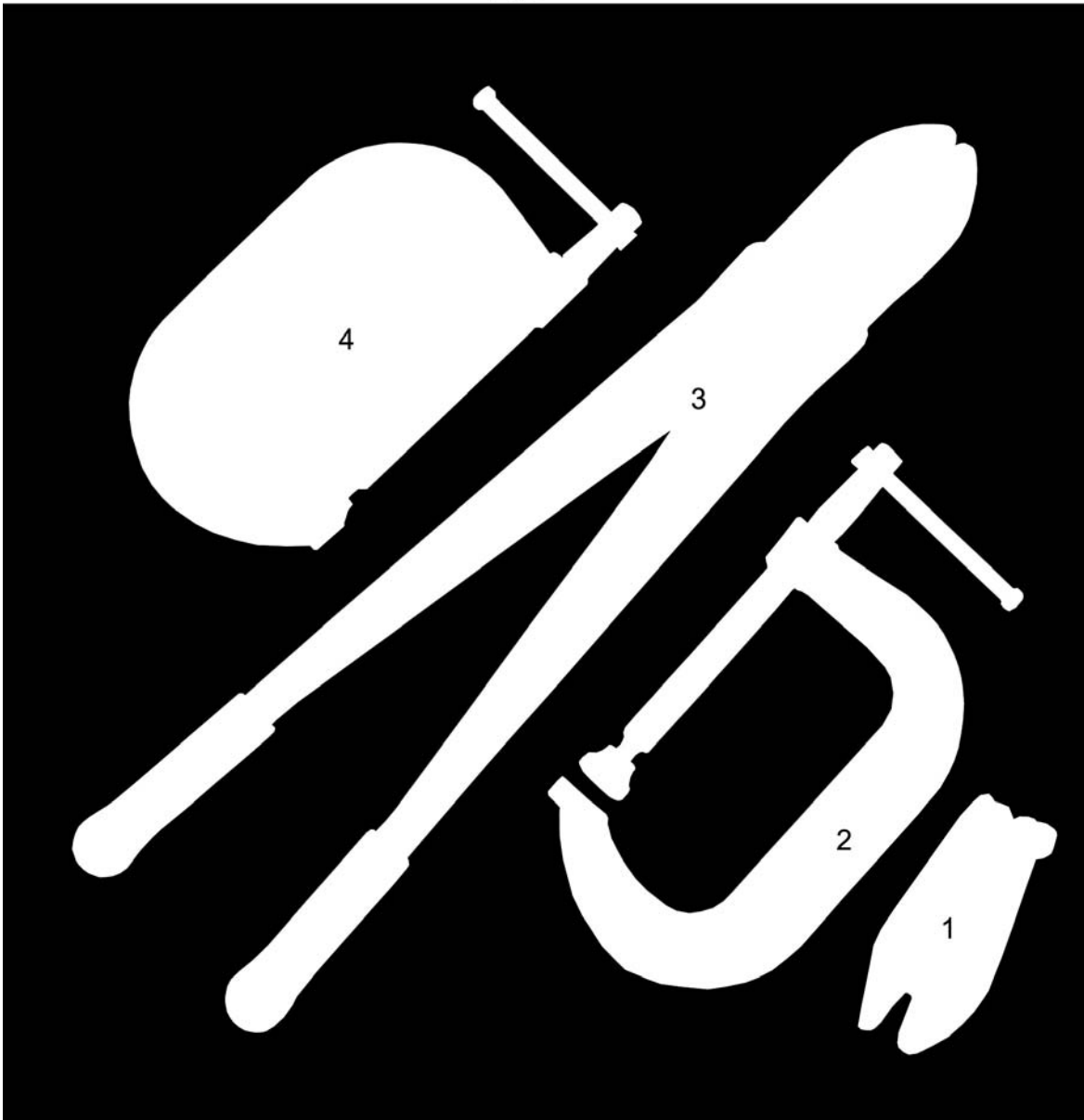

TM 9-4910-783-13&P

SATS BASE TOOL INVENTORY LIST

0058 00

INVENTORY

NOMENCLATURE	QTY	RACK	DRAWER	LOCATION	AMOUNT
WRENCH, PIPE, 10 INCH	1	L	6	1,2	
WRENCH, ADJUSTABLE, AUTOMOTIVE, 18 INCH	1	L	6	3,4	
WRENCH, ADJUSTABLE, AUTOMOTIVE, 15 INCH	1	L	6	5,6	
WRENCH, PIPE, 18 INCH	1	L	6	7,8	

L,6

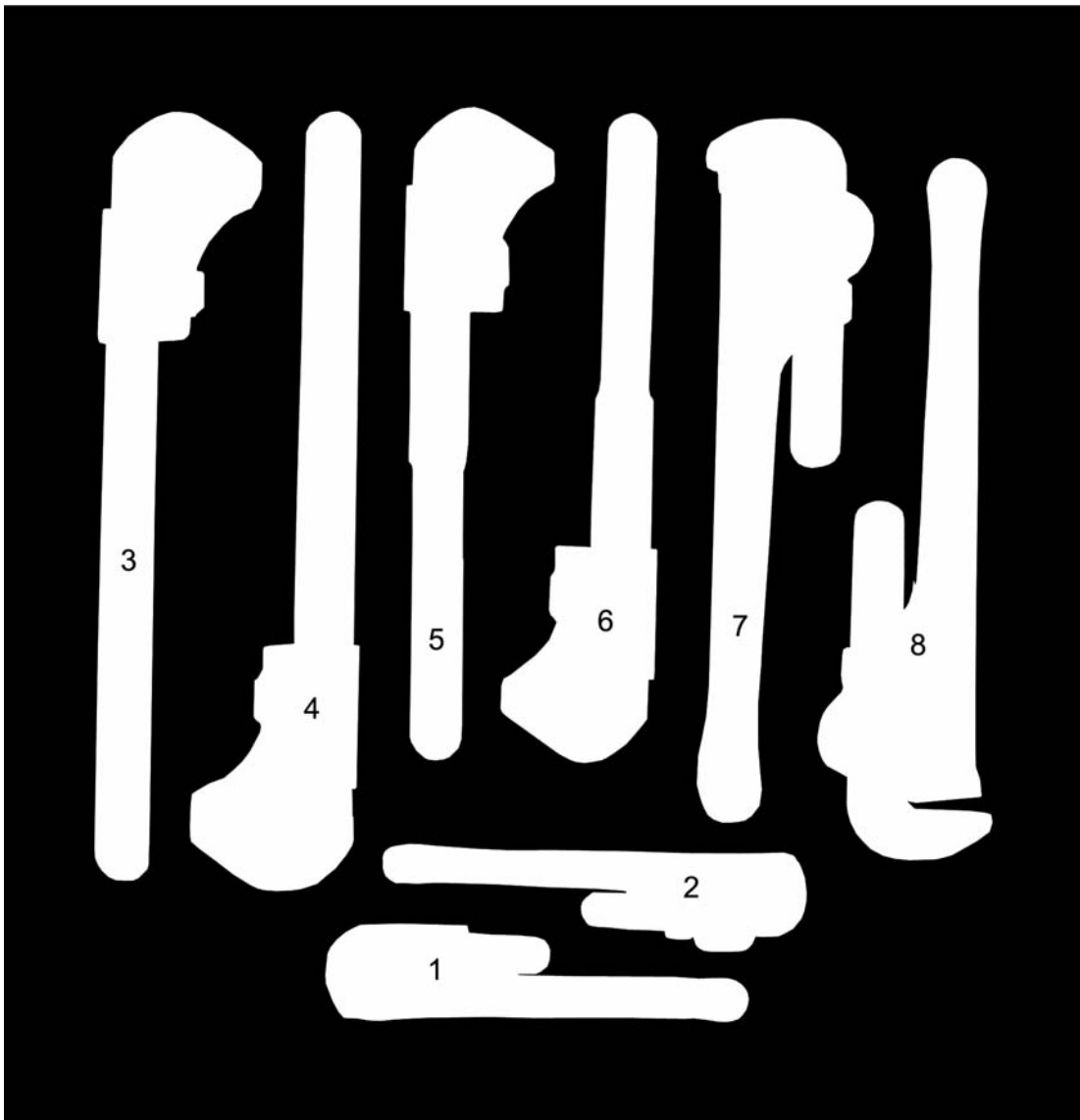

TM 9-4910-783-13&P

SATS BASE TOOL INVENTORY LIST

0058 00

THIS PAGE INTENTIONALLY LEFT BLANK

TM 9-4910-783-13&P

L,7

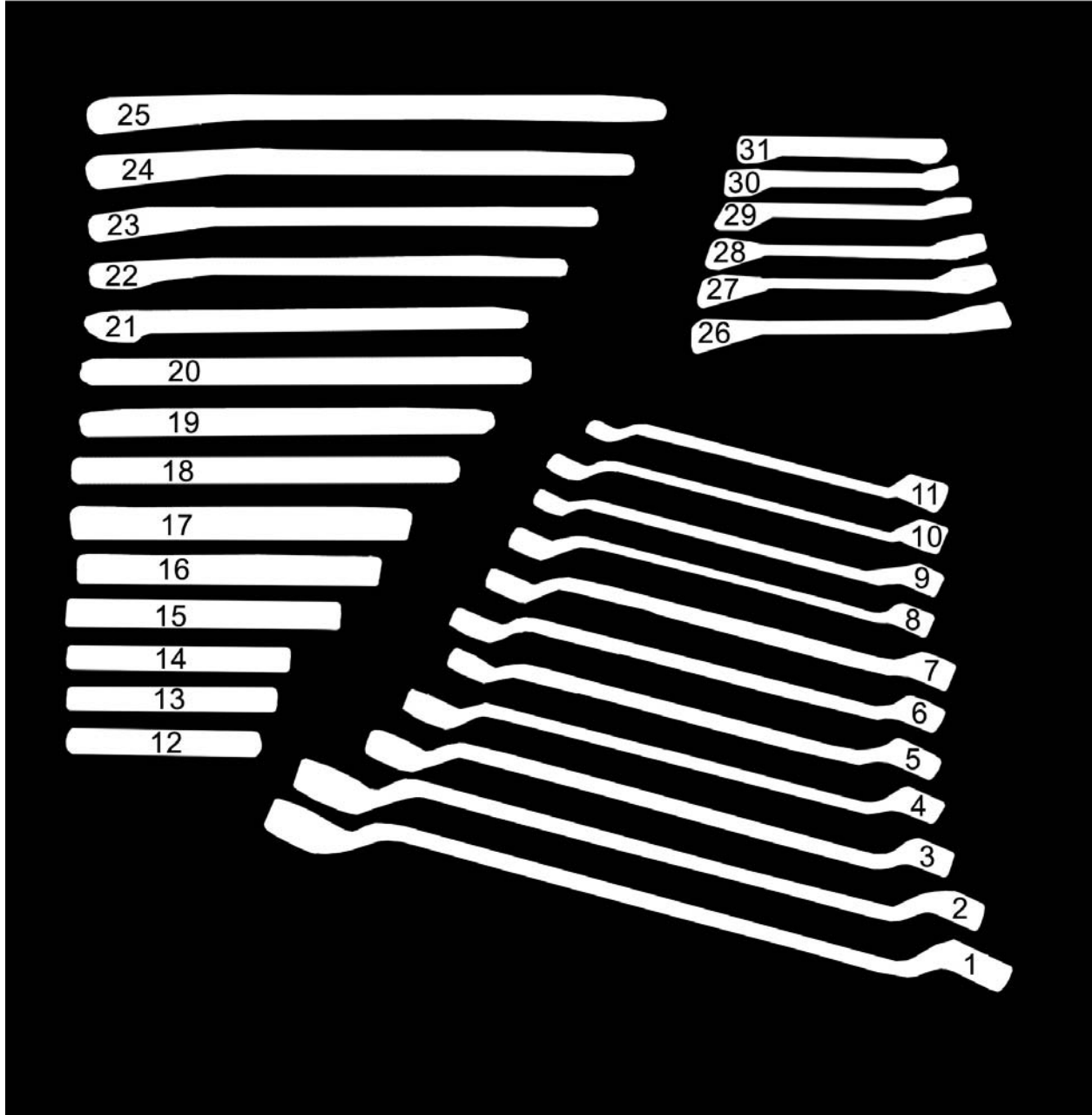

TM 9-4910-783-13&P

SATS BASE TOOL INVENTORY LIST

0058 00

INVENTORY

NOMENCLATURE	QTY	RACK	DRAWER	LOCATION	AMOUNT
WRENCH, BOX, 12PT, 30MM X 32MM	1	L	7	1	
WRENCH, BOX, 12PT, 27MM X 30MM	1	L	7	2	
WRENCH, BOX, 12PT, 22MM X 24MM	1	L	7	3	
WRENCH, BOX, 12PT, 19MM X 22MM	1	L	7	4	
WRENCH, BOX, 12PT, 18MM X 21MM	1	L	7	5	
WRENCH, BOX, 12PT, 17MM X 19MM	1	L	7	6	
WRENCH, BOX, 12PT, 16MM X 18MM	1	L	7	7	
WRENCH, BOX, 12PT, 14MM X 15MM	1	L	7	8	
WRENCH, BOX, 12PT, 13MM X 15MM	1	L	7	9	
WRENCH, BOX, 12PT, 12MM X 14MM	1	L	7	10	
WRENCH, BOX, 12PT, 10MM X 11MM	1	L	7	11	
WRENCH, OPEN-END, 6MM X 8MM	1	L	7	12	
WRENCH, OPEN-END, 7MM X 9MM	1	L	7	13	
WRENCH, OPEN-END, 10MM X 11MM	1	L	7	14	
WRENCH, OPEN-END, 12MM X 14MM	1	L	7	15	
WRENCH, OPEN-END, 13MM X 15MM	1	L	7	16	
WRENCH, OPEN-END, 16MM X 18MM	1	L	7	17	
WRENCH, OPEN-END, 17MM X 19MM	1	L	7	18	
WRENCH, OPEN-END, 20MM X 22MM	1	L	7	19	
WRENCH, OPEN-END, 22MM X 24MM	1	L	7	20	
WRENCH, OPEN-END, 21MM X 23MM	1	L	7	21	
WRENCH, OPEN-END, 24MM X 26MM	1	L	7	22	
WRENCH, OPEN-END, 25MM X 27MM	1	L	7	23	
WRENCH, OPEN-END, 28MM X 30MM	1	L	7	24	
WRENCH, OPEN-END, 30MM X 32MM	1	L	7	25	
WRENCH, FLARE NUT, 19MM X 21MM	1	L	7	26	
WRENCH, FLARE NUT, 16MM X 18MM	1	L	7	27	
WRENCH, FLARE NUT, 15MM X 17MM	1	L	7	28	
WRENCH, FLARE NUT, 13MM X 14MM	1	L	7	29	
WRENCH, FLARE NUT, 10MM X 12MM	1	L	7	30	
WRENCH, FLARE NUT, 9MM X 11MM	1	L	7	31	

TM 9-4910-783-13&P

SATS BASE TOOL INVENTORY LIST

0058 00

INVENTORY

NOMENCLATURE	QTY	RACK	DRAWER	LOCATION	AMOUNT
WRENCH, BOX, 12PT, 9/16" X 5/8"	1	L	8	1	
WRENCH, BOX, 12PT, 3/8" X 7/16"	1	L	8	2	
WRENCH, BOX, 12PT, 7/16" X 1/2"	1	L	8	3	
WRENCH, BOX, 12PT, 1/2" X 9/16"	1	L	8	4	
WRENCH, BOX, 12PT, 5/8" X 11/16"	1	L	8	5	
WRENCH, BOX, 12PT, 5/8" X 3/4"	1	L	8	6	
WRENCH, BOX, 12PT, 11/16" X 3/4"	1	L	8	7	
WRENCH, BOX, 12PT, 3/4" X 13/16"	1	L	8	8	
WRENCH, BOX, 12PT, 3/4" X 7/8"	1	L	8	9	
WRENCH, BOX, 12PT, 13/16" X 7/8"	1	L	8	10	
WRENCH, BOX, 12PT, 7/8" X 15/16"	1	L	8	11	
WRENCH, BOX, 12PT, 15/16" X 1"	1	L	8	12	
WRENCH, BOX, 12PT, 1" X 1-1/16"	1	L	8	13	
WRENCH, BOX, 12PT, 1-1/16" X 1-1/4"	1	L	8	14	
WRENCH, BOX, 12PT, 1-1/8" X 1-3/16"	1	L	8	15	
WRENCH, BOX, 12PT, 1-1/4" X 1-5/16"	1	L	8	16	
WRENCH, BOX, 12PT, 1-3/8" X 1-7/16"	1	L	8	17	
WRENCH, BOX, 12PT, 1-1/2" X 1-5/8"	1	L	8	18	

L,8

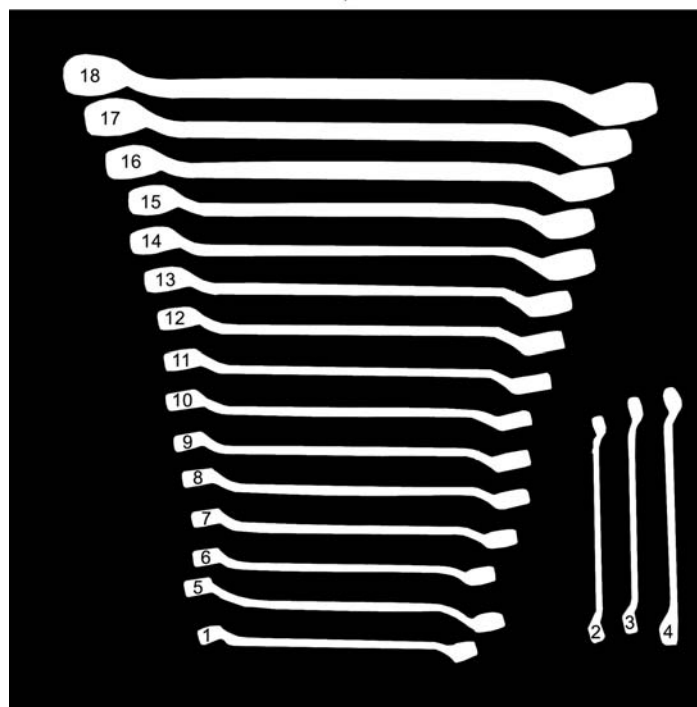

TM 9-4910-783-13&P

SATS BASE TOOL INVENTORY LIST

0058 00

THIS PAGE INTENTIONALLY LEFT BLANK

TM 9-4910-783-13&P

L, 9

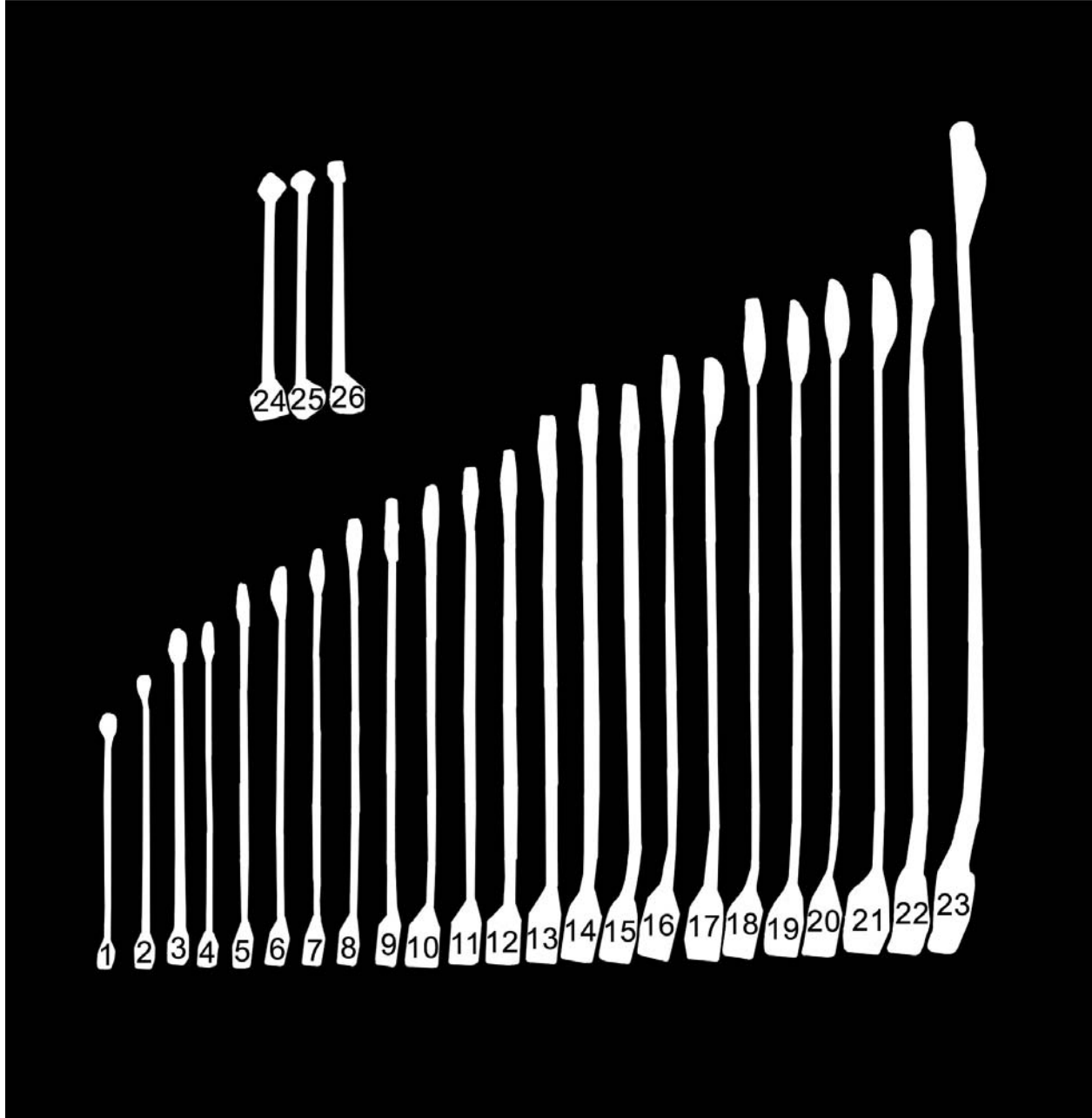

TM 9-4910-783-13&P

SATS BASE TOOL INVENTORY LIST

0058 00

					INVENTORY
NOMENCLATURE	QTY	RACK	DRAWER	LOCATION	AMOUNT
WRENCH, COMBINATION, 10MM	1	L	9	1	
WRENCH, COMBINATION, 11MM	1	L	9	2	
WRENCH, COMBINATION, 12MM	1	L	9	3	
WRENCH, COMBINATION, 13MM	1	L	9	4	
WRENCH, COMBINATION, 14MM	1	L	9	5	
WRENCH, COMBINATION, 15MM	1	L	9	6	
WRENCH, COMBINATION, 16MM	1	L	9	7	
WRENCH, COMBINATION, 17MM	1	L	9	8	
WRENCH, COMBINATION, 18MM	1	L	9	9	
WRENCH, COMBINATION, 19MM	1	L	9	10	
WRENCH, COMBINATION, 20MM	1	L	9	11	
WRENCH, COMBINATION, 21MM	1	L	9	12	
WRENCH, COMBINATION, 22MM	1	L	9	13	
WRENCH, COMBINATION, 23MM	1	L	9	14	
WRENCH, COMBINATION, 24MM	1	L	9	15	
WRENCH, COMBINATION, 25MM	1	L	9	16	
WRENCH, COMBINATION, 26MM	1	L	9	17	
WRENCH, COMBINATION, 27MM	1	L	9	18	
WRENCH, COMBINATION, 28MM	1	L	9	19	
WRENCH, COMBINATION, 29MM	1	L	9	20	
WRENCH, COMBINATION, 30MM	1	L	9	21	
WRENCH, COMBINATION, 32MM	1	L	9	22	
WRENCH, COMBINATION, 36MM	1	L	9	23	
WRENCH, COMBINATION, 7MM	1	L	9	24	
WRENCH, COMBINATION, 8MM	1	L	9	25	
WRENCH, COMBINATION, 9MM	1	L	9	26	

TM 9-4910-783-13&P

L,10

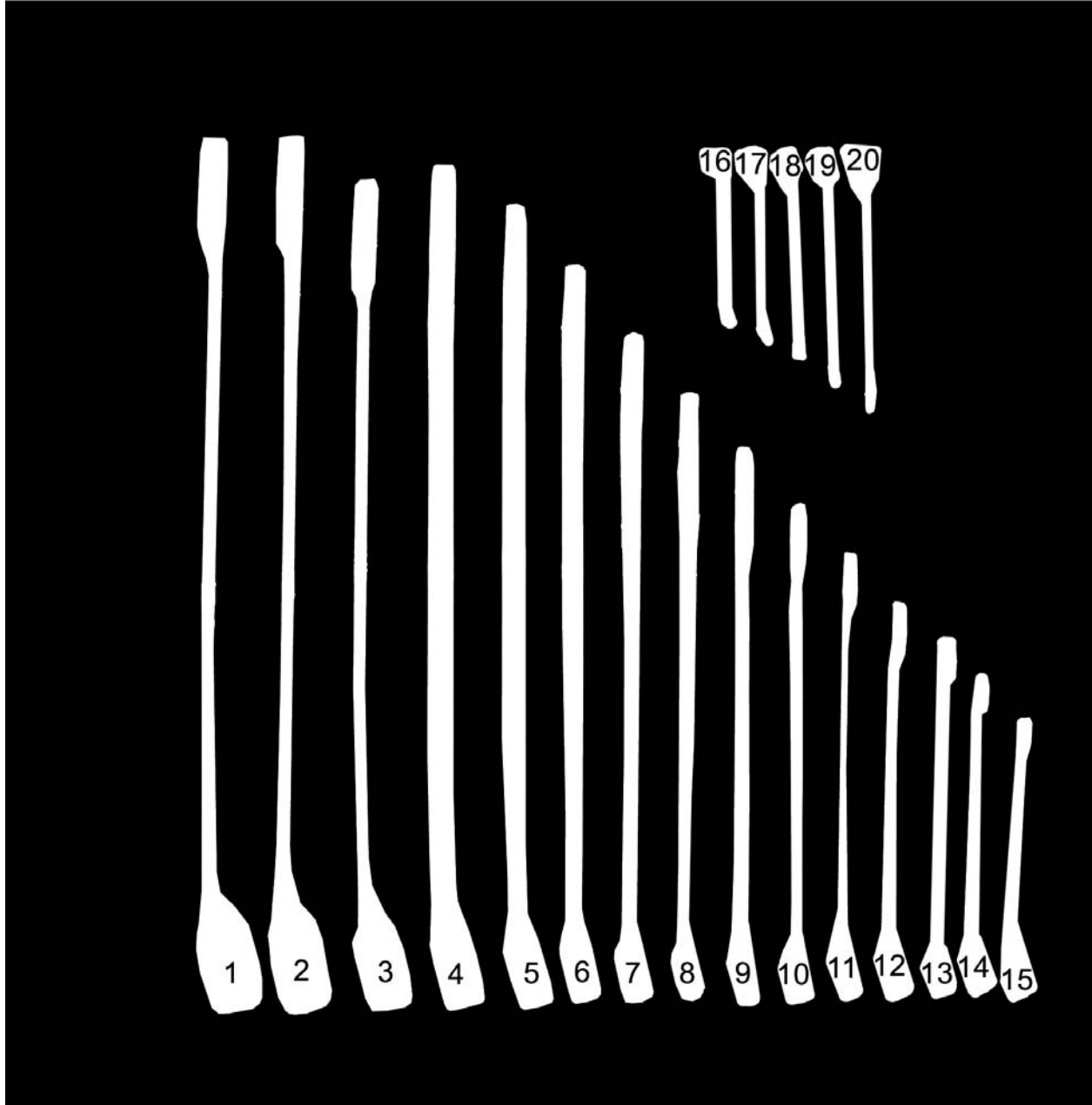

TM 9-4910-783-13&P

SATS BASE TOOL INVENTORY LIST

0058 00

INVENTORY

NOMENCLATURE	QTY	RACK	DRAWER	LOCATION	AMOUNT
WRENCH, COMBINATION, 1-1/2"	1	L	10	1	
WRENCH, COMBINATION, 1-7/16"	1	L	10	2	
WRENCH, COMBINATION, 1-3/8"	1	L	10	3	
WRENCH, COMBINATION, 1-5/16"	1	L	10	4	
WRENCH, COMBINATION, 1-1/4"	1	L	10	5	
WRENCH, COMBINATION, 1-1/8"	1	L	10	6	
WRENCH, COMBINATION, 1-1/16"	1	L	10	7	
WRENCH, COMBINATION, 1"	1	L	10	8	
WRENCH, COMBINATION, 15/16"	1	L	10	9	
WRENCH, COMBINATION, 7/8"	1	L	10	10	
WRENCH, COMBINATION, 13/16"	1	L	10	11	
WRENCH, COMBINATION, 3/4"	1	L	10	12	
WRENCH, COMBINATION, 11/16"	1	L	10	13	
WRENCH, COMBINATION, 5/8"	1	L	10	14	
WRENCH, COMBINATION, 9/16"	1	L	10	15	
WRENCH, COMBINATION, 1/4"	1	L	10	16	
WRENCH, COMBINATION, 5/16"	1	L	10	17	
WRENCH, COMBINATION, 3/8"	1	L	10	18	
WRENCH, COMBINATION, 7/16"	1	L	10	19	
WRENCH, COMBINATION, 1/2"	1	L	10	20	

TM 9-4910-783-13&P

L, 11

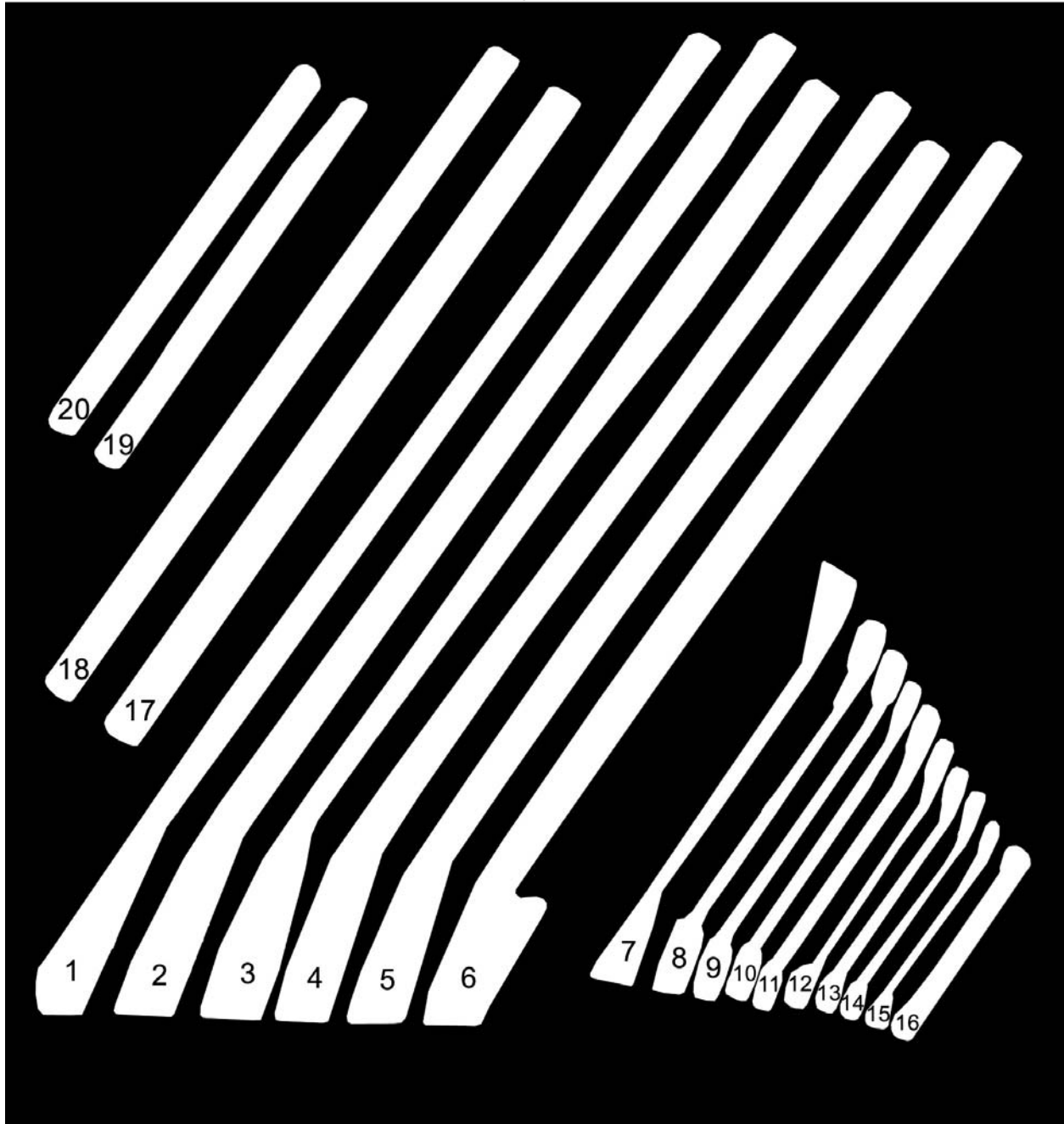

TM 9-4910-783-13&P

SATS BASE TOOL INVENTORY LIST

0058 00

INVENTORY

NOMENCLATURE	QTY	RACK	DRAWER	LOCATION	AMOUNT
WRENCH, COMBINATION, 2"	1	L	11	1	
WRENCH, COMBINATION, 1-7/8"	1	L	11	2	
WRENCH, COMBINATION, 1-13/16"	1	L	11	3	
WRENCH, COMBINATION, 1-3/4"	1	L	11	4	
WRENCH, COMBINATION, 1-11/16"	1	L	11	5	
WRENCH, COMBINATION, 1-5/8"	1	L	11	6	
WRENCH, FLARE NUT, 6PT, 7/8" X 1-1/8"	1	L	11	7	
WRENCH, FLARE NUT, 6PT, 3/4" X 1"	1	L	11	8	
WRENCH, FLARE NUT, 6PT, 3/4" X 13/16"	1	L	11	9	
WRENCH, FLARE NUT, 6PT, 5/8" X 3/4"	1	L	11	10	
WRENCH, FLARE NUT, 6PT, 5/8" X 11/16"	1	L	11	11	
WRENCH, FLARE NUT, 6PT, 1/2" X 9/16"	1	L	11	12	
WRENCH, FLARE NUT, 6PT, 7/16" X 1/2"	1	L	11	13	
WRENCH, FLARE NUT, 6PT, 3/8" X 7/16"	1	L	11	14	
WRENCH, FLARE NUT, 6PT, 5/16" X 3/8"	1	L	11	15	
WRENCH, FLARE NUT, 6PT, 1/4" X 5/16"	1	L	11	16	
WRENCH, ADJUSTABLE, 18 INCH	1	L	11	17, 18	
WRENCH, ADJUSTABLE, 10 INCH	1	L	11	19, 20	

TM 9-4910-783-13&P

SATS BASE TOOL INVENTORY LIST

0058 00

INVENTORY

NOMENCLATURE	QTY	RACK	DRAWER	LOCATION	AMOUNT
WRENCH, OPEN END, 11/16" X 3/4"	1	L	12	1	
WRENCH, OPEN END, 5/8" X 3/4"	1	L	12	2	
WRENCH, OPEN END, 13/16" X 7/8"	1	L	12	3	
WRENCH, OPEN END, 1/2" X 9/16"	1	L	12	4	
WRENCH, OPEN END, 15/16" X 1"	1	L	12	5	
WRENCH, OPEN END, 7/16" X 1/2"	1	L	12	6	
WRENCH, OPEN END, 1-1/16" X 1-1/8"	1	L	12	7	
WRENCH, OPEN END, 3/8" X 7/16"	1	L	12	8	
WRENCH, OPEN END, 1-1/4" X 1-5/16"	1	L	12	9	
WRENCH, OPEN END, 1-3/8" X 1-7/16"	1	L	12	10	
WRENCH, OPEN END, 1-1/2" X 1-5/8"	1	L	12	11	
WRENCH, OPEN END, 1-11/16" X 1-13/16"	1	L	12	12	
WRENCH, OPEN END, 1-7/8" X 2"	1	L	12	13	

L, 12

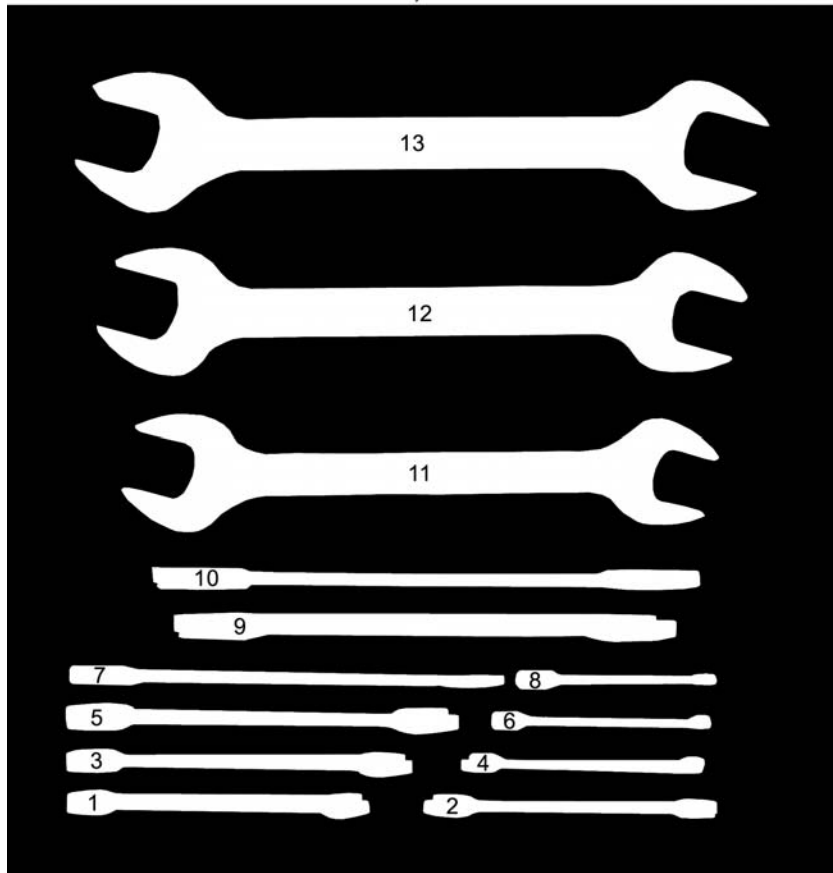

TM 9-4910-783-13&P

SATS BASE TOOL INVENTORY LIST

0058 00

INVENTORY

NOMENCLATURE	QTY	RACK	DRAWER	LOCATION	AMOUNT
BAR, PINCH, 60" (CROWBAR)	1	M		2	
EXTINGUISHER, FIRE, 5 LB CAPACITY (PROTOTYPE)	2	M		3	
TOOL KIT, TIRE SERVICE (NOTE: Stowage hooks must be clear from back of component when stowing)	1	M		4	
FOUNTAIN, EYE AND FACE	1	N		2	
PLATE, BOLSTER, 12 TON JACK, 24" X 24"	2	N		3	
PLATE, BOLSTER, 1 TON JACK, TRANSMISSION, 40" X 72"	1	N		5	
CABLE ASSEMBLY, BOOSTER	2	N		6	

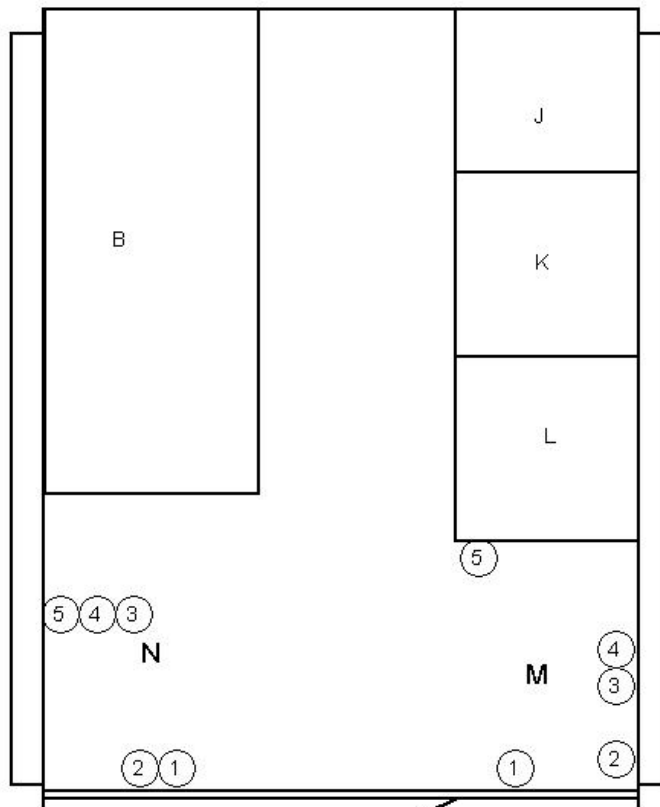

TM 9-4910-783-13&P

SATS BASE TOOL INVENTORY LIST

0058 00

INVENTORY

NOMENCLATURE	QTY	RACK	DRAWER	LOCATION	AMOUNT
CHARGER, BATTERY (NOTE: GFE ITEM)	1	P		1	
FUNNEL	1	P		2	
FUNNEL, FLEXIBLE SPOUT	1	P		2	
MEASURE, LIQUID, 2 QUART	1	P		2	
MEASURE, LIQUID, 8 QUART	1	P		2	
GREASE GUN KIT	1	P		3	
GAGE, WHEEL ALIGNMENT (NOTE: GFE)	1	P		3	
WRENCH, WHEEL STUD NUT, GEARED SOCKET	1	P		3	
CLEANING COMPOUND (PROTOTYPE ITEM ONLY)	1	P		5	
BALANCER, WHEEL	1	P		6	
BOX, TOTE	5	P		7	
WRENCH, TORQUE, CLICK, RATCHETING, 3/4" DRIVE, 600 FT-LB	1	P		8	

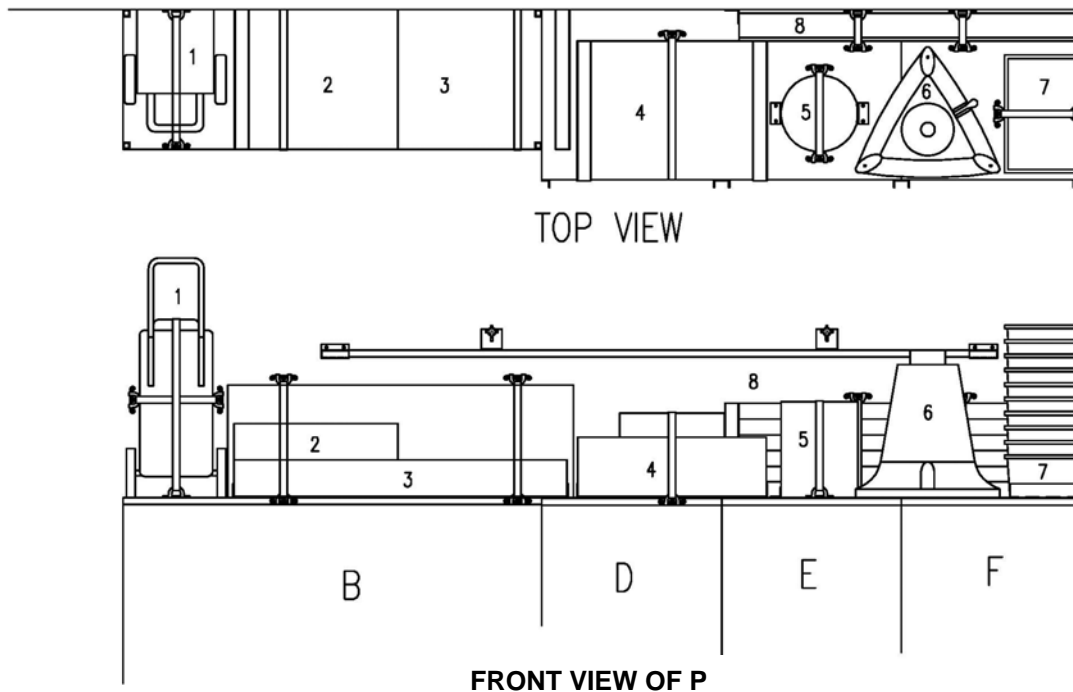

TM 9-4910-783-13&P

SATS BASE TOOL INVENTORY LIST

0058 00

NOMENCLATURE	QTY	RACK	DRAWER	LOCATION	INVENTORY AMOUNT
CREEPER, MECHANIC'S	5	Q		1	
CAN, RADIATOR FILLING	2	Q		2	
TRESTLE, HOIST, PORTABLE (NOTE: GFE ITEM)	4	Q		3	

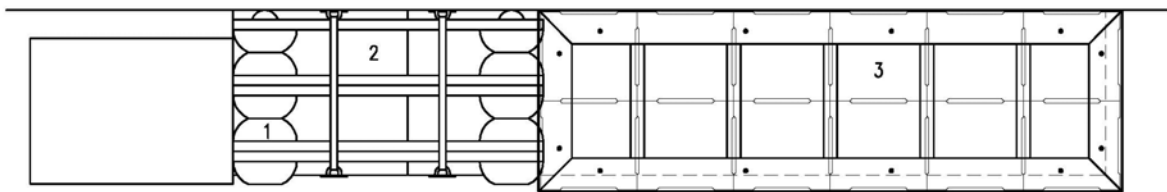

TOP VIEW

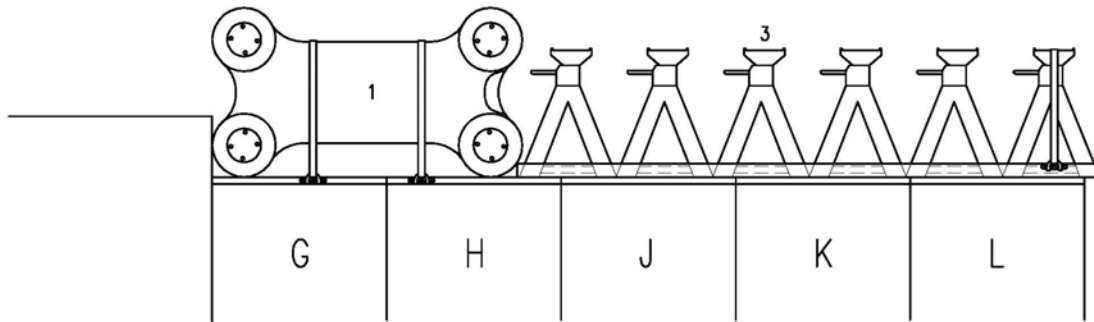

FRONT VIEW OF Q

TM 9-4910-783-13&P

SATS BASE TOOL INVENTORY LIST

0058 00

INVENTORY

NOMENCLATURE	QTY	RACK	DRAWER	LOCATION	AMOUNT
PAN, DRAIN	1	R		1	
HAMMER, SLEDGE, DOUBLE FACED, 10 LB	2	R		2	
BAR, PINCH, 36"	1	R		3	

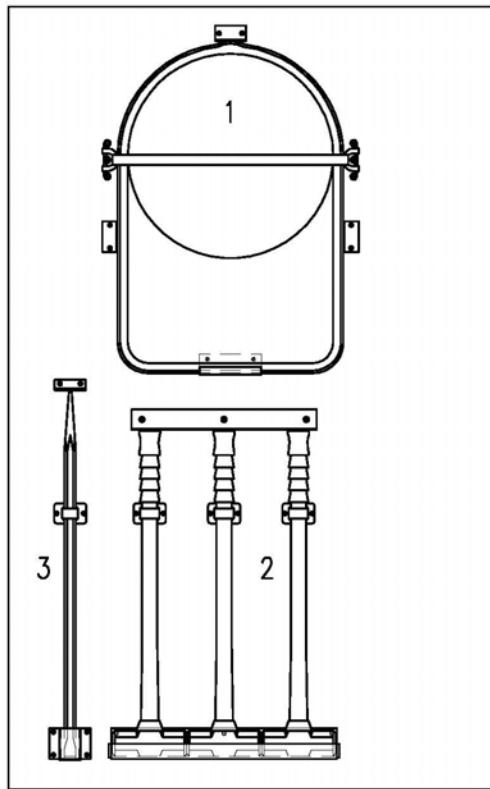

FRONT INTERIOR
N

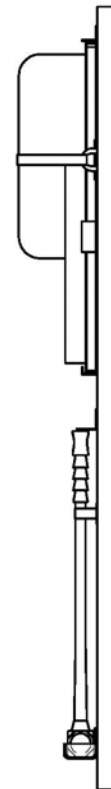

SIDE VIEW

VIEW OF R

TM 9-4910-783-13&P

APPENDIX B

FIELD MAINTENANCE MODULE 1 (FMM1) TOOLS

INVENTORY GUIDE

STANDARD AUTOMOTIVE TOOL SET (SATS)

TM 9-4910-783-13&P

SATS FIELD MAINTENANCE MODULE #1 (FMM1) COMPONENT LIST

0059 00

NOMENCLATURE	QTY	RACK	DRAWER	LOCATION
ADAPTER, 3/4" DR TO 1/2" DR, 1/2"	1	E	1	8
ADAPTER, 3/8" DR MALE TO 1/2" DR FEMALE	1	E	4	88
ADAPTER, SOCKET WRENCH DRIVE, 1/2" MALE - 3/8" FEMALE	1	F	8	71
ADAPTER, SOCKET WRENCH DRIVE, 1/2" MALE - 3/8" FEMALE	1	F	10	71
ADAPTER, SOCKET WRENCH DRIVE, 1/2" FEMALE - 1/2" MALE	1	F	8	76
ADAPTER, SOCKET WRENCH DRIVE, 1/2" FEMALE - 1/2" MALE	1	F	10	76
ADAPTER, SOCKET WRENCH DRIVE, 1/4" MALE - 3/8" FEMALE	1	F	8	70
ADAPTER, SOCKET WRENCH DRIVE, 1/4" MALE - 3/8" FEMALE	1	F	10	70
ADAPTER, SOCKET WRENCH DRIVE, 3/4" MALE - 1/2" FEMALE	1	F	8	74
ADAPTER, SOCKET WRENCH DRIVE, 3/4" MALE - 1/2" FEMALE	1	F	10	74
ADAPTER, SOCKET WRENCH DRIVE, 3/8" MALE - 1/2" FEMALE	1	F	8	75
ADAPTER, SOCKET WRENCH DRIVE, 3/8" MALE - 1/2" FEMALE	1	F	10	75
ADAPTER, SOCKET WRENCH DRIVE, 3/8" MALE - 1/4" FEMALE	1	F	9	19
ADAPTER, SOCKET WRENCH DRIVE, 3/8" MALE - 1/4" FEMALE	1	F	11	19
BAR, EXTENSION, 1/2" DR, 2.5"	1	E	4	80
BAR, EXTENSION, 1/2" DR, 4.55"	1	E	4	83
BAR, EXTENSION, 1/2" DR, 9.5"	1	E	4	85
BAR, EXTENSION, IMPACT WRENCH, 3/8" DR, 2.5"	1	E	4	91
BAR, EXTENSION, IMPACT WRENCH, 3/8" DR, 5.5"	1	E	4	87
BAR, TORQUE WRENCH	1	P		4
BEARING CUP PULLER ATTACHMENT	1	E	6	2
BEARING SPLITTER 15/16" MAX	1	E	6	5
BEARING SPLITTER, 2" MAX	1	E	6	6
BEARING SPLITTER, 4-5/8" MAX	1	E	6	3
BOLTS	1	E	7	5
BOLTS FOR MECHANICAL PULLER SET	1	E	7	7
BOLTS FOR SLIDE HAMMER PULLER	1	E	7	8
CALIPER, MICROMETER, INSIDE	1	E	5	1
CALIPER, VERNIER	1	E	5	8
DIE SET, METAL STAMPING, HAND, ALPHABETIC	1	G	6	1
DIE SET, METAL STAMPING, HAND, ALPHABETIC AND NUMERIC	1	G	6	6
DRESSER, ABRASIVE WHEEL	1	G	3	4
DRILL, ELECTRIC, PORTABLE, RIGHT ANGLE, 3/8"	2	G	4	1,2
DRILL, ELECTRIC, PORTABLE, RIGHT ANGLE, 1/2"	1	G	5	2
DRILL, ELECTRIC, PORTABLE, 3/8"	1	G	5	1
DRILL-DRIVER, BATTERY OPERATED, RECHARGEABLE, RIGHT ANGLE, 3/8"	1	G	4	3
DRILL-DRIVER, BATTERY OPERATED, RECHARGEABLE	1	G	5	3

TM 9-4910-783-13&P

SATS FIELD MAINTENANCE MODULE #1 (FMM1) COMPONENT LIST

0059 00

NOMENCLATURE	QTY	RACK	DRAWER	LOCATION
EXTENSION ROD	1	E	7	3
EXTENSION ROD	1	E	7	4
EXTENSION, 1/2" DR, 10" LONG	1	F	9	69
EXTENSION, 1/2" DR, 10" LONG	1	F	11	69
EXTENSION, 1/2" DR, 3" LONG	1	F	9	97
EXTENSION, 1/2" DR, 3" LONG	1	F	11	97
EXTENSION, 1/2" DR, 5" LONG	1	F	9	96
EXTENSION, 1/2" DR, 5" LONG	1	F	11	96
EXTENSION, 1/4" DR, 10" LONG	1	F	9	17
EXTENSION, 1/4" DR, 10" LONG	1	F	11	17
EXTENSION, 1/4" DR, 3" LONG	1	F	9	18
EXTENSION, 1/4" DR, 3" LONG	1	F	11	18
EXTENSION, 1/4" DR, 6" LONG	1	F	9	16
EXTENSION, 1/4" DR, 6" LONG	1	F	11	16
EXTENSION, 1" DR, 17" LONG	1	E	2	3
EXTENSION, 3/4" DR, 15" LONG	1	E	1	1
EXTENSION, 3/4" DR, 4.5" LONG	1	E	1	3
EXTENSION, 3/4" DR, 7.5" LONG	1	E	1	2
EXTENSION, 3/8" DR, 3" LONG	1	F	8	1
EXTENSION, 3/8" DR, 3" LONG	1	F	10	1
EXTENSION, 3/8" DR, 6" LONG	1	F	8	2
EXTENSION, 3/8" DR, 6" LONG	1	F	10	2
EXTENSION, 3/8" DR, 9.5" LONG	1	F	8	3
EXTENSION, 3/8" DR, 9.5" LONG	1	F	10	3
EXTENSION, 1" DR, 8" LONG	1	E	2	2
FEMALE THREADED ADAPTER, 1-1/4"	1	E	7	17
FEMALE THREADED ADAPTER, 1-1/8"	1	E	7	21
FEMALE THREADED ADAPTER, 1"	1	E	7	23
FEMALE THREADED ADAPTER, 1/2"	1	E	7	14
FEMALE THREADED ADAPTER, 3/4"	1	E	7	27
FEMALE THREADED ADAPTER, 5/8"	1	E	7	28
FEMALE THREADED ADAPTER, 7/8"	1	E	7	25
FLANGE-TYPE PULLER	1	E	7	1
GAGE, STOCK SET, THICKNESS	3	E	5	4,5,7
GEAR AND PULLEY PULLERS, 13"	1	E	7	29
GOGGLES, INDUSTRIAL	1	G	7	31
GREASE GUN KIT	1	P		3

TM 9-4910-783-13&P

SATS FIELD MAINTENANCE MODULE #1 (FMM1) COMPONENT LIST

0059 00

NOMENCLATURE	QTY	RACK	DRAWER	LOCATION
GRINDING MACHINE, UTILITY	1	B	3	2
HANDLE, RATCHET, 1/2" DR, 10" LONG	1	F	8	5
HANDLE, RATCHET, 1/2" DR, 10" LONG	1	F	10	5
HANDLE, RATCHET, 3/4" DR, 17" LONG	1	E	1	11
HANDLE, RATCHET, 3/8" DR, 6" LONG	1	F	8	4
HANDLE, RATCHET, 3/8" DR, 6" LONG	1	F	10	4
HANDLE, REVERSIBLE RATCHET, SOCKET WRENCH, 1/4" DR, 4.375" LONG	1	F	9	15
HANDLE, REVERSIBLE RATCHET, SOCKET WRENCH, 1/4" DR, 4.375" LONG	1	F	11	15
HANDLE, SLIDING-T, 3/4" DR, 17" LONG	1	E	1	10
HANDLE, TEE SLIDING, 1" DR, 28" LONG	1	E	2	5
HOLDER, PUNCH AND CHISEL	1	G	7	23
INDICATOR, DIAL	1	E	5	6
JACK KIT, HYDRAULIC, HAND	1	B	4	2
JACK, BOTTLE, HYDRAULIC, HAND, 30 TON	1	B	3	3
2-JAW PULLER, 13 TON, 11"	1	E	6	4
2-JAW PULLER, 2 TON, 3-1/4"	1	E	6	7
2-JAW PULLER, 5 TON, 3-1/4"	1	E	6	9
2-JAW PULLER, 7 TON, 5"	1	E	6	8
JOINT, UNIVERSAL, 1/2" DR	1	E	4	84
JOINT, UNIVERSAL, 1/2" DR	1	F	8	77
JOINT, UNIVERSAL, 1/2" DR	1	F	10	77
JOINT, UNIVERSAL, 1/4" DR	1	F	9	20
JOINT, UNIVERSAL, 1/4" DR	1	F	11	20
JOINT, UNIVERSAL, 3/4" DR	1	E	1	9
JOINT, UNIVERSAL, 3/8" DR	1	E	4	89
JOINT, UNIVERSAL, 3/8" DR	1	F	8	73
JOINT, UNIVERSAL, 3/8" DR	1	F	10	73
LIFT, TRANSMISSION AND DIFFERENTIAL	1	A		3a
LIGHT, BATTERY 18V, RECHARGEABLE, CASE	1	G	8	1
MULTIMETER	1	G	7	25
PILOT BEARING PULLER	1	E	7	2
PLATE, BOLSTER, 1 TON JACK, TRANSMISSION, 48" X 72"	1	N		5
PLATE, BOLSTER, 36" X 36"	1	N		4
PLIERS SET, RETAINING RING	1	G	8	2
PLIERS, MULTIPLE POSITION	1	G	6	3
PLIERS, MULTIPLE POSITION, ELECTRICAL CONNECTOR	1	G	7	24
PULLER KIT, UNIVERSAL	1	G	8	3

TM 9-4910-783-13&P

SATS FIELD MAINTENANCE MODULE #1 (FMM1) COMPONENT LIST

0059 00

NOMENCLATURE	QTY	RACK	DRAWER	LOCATION
PULLER SET, MECHANICAL	1	E	6	1-9
PULLER SET, MECHANICAL	1	E	7	1-29
PULLER, PITTMAN ARM	1	E	6	1
PUNCH AND CHISEL SET, CHISEL, 1" DIA, 1-3/16"	1	G	7	13
PUNCH AND CHISEL SET, CHISEL, 1/2" DIA, 5/8"	1	G	7	9
PUNCH AND CHISEL SET, CHISEL, 1/4" DIA, 5/16"	1	G	7	6
PUNCH AND CHISEL SET, CHISEL, 3/16" DIA, 1/4"	1	G	7	5
PUNCH AND CHISEL SET, CHISEL, 3/4" DIA, 7/8"	1	G	7	11
PUNCH AND CHISEL SET, CHISEL, 5/16" DIA, 3/8"	1	G	7	7
PUNCH AND CHISEL SET, CHISEL, 5/8" DIA, 3/4"	1	G	7	10
PUNCH AND CHISEL SET, CHISEL, 7/16" DIA, 1/2"	1	G	7	8
PUNCH AND CHISEL SET, CHISEL, 7/8" DIA, 1"	1	G	7	12
PUNCH AND CHISEL SET, PUNCH, 1/2"	1	G	7	20
PUNCH AND CHISEL SET, PUNCH, 1/2", 1/4" PT	1	G	7	14
PUNCH AND CHISEL SET, PUNCH, 1/4", 3/32" PT	1	G	7	19
PUNCH AND CHISEL SET, PUNCH, 3/8"	1	G	7	21
PUNCH AND CHISEL SET, PUNCH, 3/8", 3/16" PT	1	G	7	16
PUNCH AND CHISEL SET, PUNCH, 5/16"	1	G	7	22
PUNCH AND CHISEL SET, PUNCH, 5/16", 1/8" PT	1	G	7	18
PUNCH AND CHISEL SET, PUNCH, 5/16", 5/32" PT	1	G	7	17
PUNCH AND CHISEL SET, PUNCH, 7/16", 7/32" PT	1	G	7	15
PUNCH AND CHISEL SET, PUNCH, 1/2" DIA, 1/4" PT	1	G	7	2
PUNCH AND CHISEL SET, PUNCH, 1/2" DIA, 1/4" PT	1	G	7	26
PUNCH AND CHISEL SET, PUNCH, 1/4" DIA, 3/32" PT	1	G	7	30
PUNCH AND CHISEL SET, PUNCH, 3/8" DIA, 3/16" PT	1	G	7	3
PUNCH AND CHISEL SET, PUNCH, 3/8" DIA, 3/16" PT	1	G	7	28
PUNCH AND CHISEL SET, PUNCH, 5/16" DIA, 1/8" PT	1	G	7	4
PUNCH AND CHISEL SET, PUNCH, 5/16" DIA, 1/8" PT	1	G	7	29
PUNCH AND CHISEL SET, PUNCH, 7/16" DIA, 7/32" PT	1	G	7	27
PUSH PULLER W/ 6-3/4" LEGS	1	E	7	18
RATCHET, REVERSIBLE, 1" DR	1	E	2	4
SCREWDRIVER ATTACHMENT, TORX BIT, 1/4" DR, T-8	1	E	2	12
SCREWDRIVER ATTACHMENT, TORX BIT, 1/4" DR, T-10	1	E	2	13
SCREWDRIVER ATTACHMENT, TORX BIT, 1/4" DR, T-15	1	E	2	14
SCREWDRIVER ATTACHMENT, TORX BIT, 1/4" DR, T-20	1	E	2	15
SCREWDRIVER ATTACHMENT, TORX BIT, 1/4" DR, T-25	1	E	2	16
SCREWDRIVER ATTACHMENT, TORX BIT, 1/4" DR, T-27	1	E	2	17

TM 9-4910-783-13&P

SATS FIELD MAINTENANCE MODULE #1 (FMM1) COMPONENT LIST

0059 00

NOMENCLATURE	QTY	RACK	DRAWER	LOCATION
SCREWDRIVER ATTACHMENT, TORX BIT, 3/8" DR, T-40	1	E	2	7
SCREWDRIVER ATTACHMENT, TORX BIT, 3/8" DR, T-45	1	E	2	8
SCREWDRIVER ATTACHMENT, TORX BIT, 3/8" DR, T-47	1	E	2	9
SCREWDRIVER ATTACHMENT, TORX BIT, 3/8" DR, T-50	1	E	2	10
SCREWDRIVER ATTACHMENT, TORX BIT, 3/8" DR, T-55	1	E	2	11
SCREWDRIVER ATTACHMENT, TORX BIT, T-30	1	E	2	6
SLIDE HAMMER PULLER	1	E	7	6
SLIDING DRIVE PLUG, 1" DR, 2-1/72"	1	E	2	1
SLING, ENGINE AND TRANSMISSION, 2 TON	2	B	4	1
SLING, ENGINE AND TRANSMISSION, 3 TON	1	M		1
SOCKET, DOUBLE-END IMPACT, 3/4" X 13/16"	1	E	4	24
SOCKET, IMPACT WRENCH, 1/2" DR, 6 PT, 1"	1	E	4	76
SOCKET, IMPACT WRENCH, 1/2" DR, 6 PT, 1/2"	1	E	4	71
SOCKET, IMPACT WRENCH, 1/2" DR, 6 PT, 11/16"	1	E	4	65
SOCKET, IMPACT WRENCH, 1/2" DR, 6 PT, 1-1/16"	1	E	4	75
SOCKET, IMPACT WRENCH, 1/2" DR, 6 PT, 12MM	1	E	4	52
SOCKET, IMPACT WRENCH, 1/2" DR, 6 PT, 13/16"	1	E	4	79
SOCKET, IMPACT WRENCH, 1/2" DR, 6 PT, 13MM	1	E	4	63
SOCKET, IMPACT WRENCH, 1/2" DR, 6 PT, 14MM	1	E	4	68
SOCKET, IMPACT WRENCH, 1/2" DR, 6 PT, 15/16"	1	E	4	77
SOCKET, IMPACT WRENCH, 1/2" DR, 6 PT, 15MM	1	E	4	74
SOCKET, IMPACT WRENCH, 1/2" DR, 6 PT, 16MM	1	E	4	81
SOCKET, IMPACT WRENCH, 1/2" DR, 6 PT, 17MM	1	E	4	86
SOCKET, IMPACT WRENCH, 1/2" DR, 6 PT, 18MM	1	E	4	90
SOCKET, IMPACT WRENCH, 1/2" DR, 6 PT, 19MM	1	E	4	93
SOCKET, IMPACT WRENCH, 1/2" DR, 6 PT, 21MM	1	E	4	94
SOCKET, IMPACT WRENCH, 1/2" DR, 6 PT, 22MM	1	E	4	95
SOCKET, IMPACT WRENCH, 1/2" DR, 6 PT, 24MM	1	E	4	96
SOCKET, IMPACT WRENCH, 1/2" DR, 6 PT, 27MM	1	E	4	97
SOCKET, IMPACT WRENCH, 1/2" DR, 6 PT, 3/4"	1	E	4	73
SOCKET, IMPACT WRENCH, 1/2" DR, 6 PT, 3/8"	1	E	4	69
SOCKET, IMPACT WRENCH, 1/2" DR, 6 PT, 5/8"	1	E	4	64
SOCKET, IMPACT WRENCH, 1/2" DR, 6 PT, 7/16"	1	E	4	70
SOCKET, IMPACT WRENCH, 1/2" DR, 6 PT, 7/8"	1	E	4	78
SOCKET, IMPACT WRENCH, 1/2" DR, 6 PT, 9/16"	1	E	4	72
SOCKET, IMPACT WRENCH, 1/2" DR, 6 PT, DEEP, 1"	1	E	4	14
SOCKET, IMPACT WRENCH, 1/2" DR, 6 PT, DEEP, 1/2"	1	E	4	22

TM 9-4910-783-13&P

SATS FIELD MAINTENANCE MODULE #1 (FMM1) COMPONENT LIST

0059 00

NOMENCLATURE	QTY	RACK	DRAWER	LOCATION
SOCKET, IMPACT WRENCH, 1/2" DR, 6 PT, DEEP, 11/16"	1	E	4	19
SOCKET, IMPACT WRENCH, 1/2" DR, 6 PT, DEEP, 1-1/16"	1	E	4	13
SOCKET, IMPACT WRENCH, 1/2" DR, 6 PT, DEEP, 12MM	1	E	4	1
SOCKET, IMPACT WRENCH, 1/2" DR, 6 PT, DEEP, 13/16"	1	E	4	17
SOCKET, IMPACT WRENCH, 1/2" DR, 6 PT, DEEP, 13MM	1	E	4	2
SOCKET, IMPACT WRENCH, 1/2" DR, 6 PT, DEEP, 14MM	1	E	4	3
SOCKET, IMPACT WRENCH, 1/2" DR, 6 PT, DEEP, 15/16"	1	E	4	15
SOCKET, IMPACT WRENCH, 1/2" DR, 6 PT, DEEP, 15MM	1	E	4	4
SOCKET, IMPACT WRENCH, 1/2" DR, 6 PT, DEEP, 16MM	1	E	4	5
SOCKET, IMPACT WRENCH, 1/2" DR, 6 PT, DEEP, 17MM	1	E	4	6
SOCKET, IMPACT WRENCH, 1/2" DR, 6 PT, DEEP, 18MM	1	E	4	7
SOCKET, IMPACT WRENCH, 1/2" DR, 6 PT, DEEP, 19MM	1	E	4	8
SOCKET, IMPACT WRENCH, 1/2" DR, 6 PT, DEEP, 21MM	1	E	4	9
SOCKET, IMPACT WRENCH, 1/2" DR, 6 PT, DEEP, 22MM	1	E	4	10
SOCKET, IMPACT WRENCH, 1/2" DR, 6 PT, DEEP, 24MM	1	E	4	11
SOCKET, IMPACT WRENCH, 1/2" DR, 6 PT, DEEP, 27MM	1	E	4	12
SOCKET, IMPACT WRENCH, 1/2" DR, 6 PT, DEEP, 3/4"	1	E	4	18
SOCKET, IMPACT WRENCH, 1/2" DR, 6 PT, DEEP, 3/8"	1	E	4	38
SOCKET, IMPACT WRENCH, 1/2" DR, 6 PT, DEEP, 5/8"	1	E	4	20
SOCKET, IMPACT WRENCH, 1/2" DR, 6 PT, DEEP, 7/16"	1	E	4	23
SOCKET, IMPACT WRENCH, 1/2" DR, 6 PT, DEEP, 7/8"	1	E	4	16
SOCKET, IMPACT WRENCH, 1/2" DR, 6 PT, DEEP, 9/16"	1	E	4	21
SOCKET, IMPACT WRENCH, 3/8" DR, 6 PT, 1/2"	1	E	4	50
SOCKET, IMPACT WRENCH, 3/8" DR, 6 PT, 1/4"	1	E	4	66
SOCKET, IMPACT WRENCH, 3/8" DR, 6 PT, 10MM	1	E	4	28
SOCKET, IMPACT WRENCH, 3/8" DR, 6 PT, 11/16"	1	E	4	47
SOCKET, IMPACT WRENCH, 3/8" DR, 6 PT, 11MM	1	E	4	29
SOCKET, IMPACT WRENCH, 3/8" DR, 6 PT, 12MM	1	E	4	30
SOCKET, IMPACT WRENCH, 3/8" DR, 6 PT, 13MM	1	E	4	31
SOCKET, IMPACT WRENCH, 3/8" DR, 6 PT, 14MM	1	E	4	32
SOCKET, IMPACT WRENCH, 3/8" DR, 6 PT, 15MM	1	E	4	33
SOCKET, IMPACT WRENCH, 3/8" DR, 6 PT, 16MM	1	E	4	34
SOCKET, IMPACT WRENCH, 3/8" DR, 6 PT, 17MM	1	E	4	35
SOCKET, IMPACT WRENCH, 3/8" DR, 6 PT, 18MM	1	E	4	36
SOCKET, IMPACT WRENCH, 3/8" DR, 6 PT, 19MM	1	E	4	37
SOCKET, IMPACT WRENCH, 3/8" DR, 6 PT, 3/4"	1	E	4	46
SOCKET, IMPACT WRENCH, 3/8" DR, 6 PT, 3/8"	1	E	4	62

TM 9-4910-783-13&P

SATS FIELD MAINTENANCE MODULE #1 (FMM1) COMPONENT LIST

0059 00

NOMENCLATURE	QTY	RACK	DRAWER	LOCATION
SOCKET, IMPACT WRENCH, 3/8" DR, 6 PT, 5/16"	1	E	4	67
SOCKET, IMPACT WRENCH, 3/8" DR, 6 PT, 5/8"	1	E	4	48
SOCKET, IMPACT WRENCH, 3/8" DR, 6 PT, 7/16"	1	E	4	51
SOCKET, IMPACT WRENCH, 3/8" DR, 6 PT, 9/16"	1	E	4	49
SOCKET, IMPACT WRENCH, 3/8" DR, 6 PT, DEEP, 1/2"	1	E	4	57
SOCKET, IMPACT WRENCH, 3/8" DR, 6 PT, DEEP, 1/4"	1	E	4	61
SOCKET, IMPACT WRENCH, 3/8" DR, 6 PT, DEEP, 10MM	1	E	4	27
SOCKET, IMPACT WRENCH, 3/8" DR, 6 PT, DEEP, 11/16"	1	E	4	54
SOCKET, IMPACT WRENCH, 3/8" DR, 6 PT, DEEP, 11MM	1	E	4	26
SOCKET, IMPACT WRENCH, 3/8" DR, 6 PT, DEEP, 12MM	1	E	4	25
SOCKET, IMPACT WRENCH, 3/8" DR, 6 PT, DEEP, 13MM	1	E	4	39
SOCKET, IMPACT WRENCH, 3/8" DR, 6 PT, DEEP, 14MM	1	E	4	40
SOCKET, IMPACT WRENCH, 3/8" DR, 6 PT, DEEP, 15MM	1	E	4	41
SOCKET, IMPACT WRENCH, 3/8" DR, 6 PT, DEEP, 16MM	1	E	4	42
SOCKET, IMPACT WRENCH, 3/8" DR, 6 PT, DEEP, 17MM	1	E	4	43
SOCKET, IMPACT WRENCH, 3/8" DR, 6 PT, DEEP, 18MM	1	E	4	44
SOCKET, IMPACT WRENCH, 3/8" DR, 6 PT, DEEP, 19MM	1	E	4	45
SOCKET, IMPACT WRENCH, 3/8" DR, 6 PT, DEEP, 3/4"	1	E	4	53
SOCKET, IMPACT WRENCH, 3/8" DR, 6 PT, DEEP, 3/8"	1	E	4	59
SOCKET, IMPACT WRENCH, 3/8" DR, 6 PT, DEEP, 5/16"	1	E	4	60
SOCKET, IMPACT WRENCH, 3/8" DR, 6 PT, DEEP, 5/8"	1	E	4	55
SOCKET, IMPACT WRENCH, 3/8" DR, 6 PT, DEEP, 7/16"	1	E	4	58
SOCKET, IMPACT WRENCH, 3/8" DR, 6 PT, DEEP, 9/16"	1	E	4	56
SOCKET, SOCKET WRENCH, 1" DR, 1-1/2"	1	E	3	2
SOCKET, SOCKET WRENCH, 1" DR, 1-7/16"	1	E	3	1
SOCKET, SOCKET WRENCH, 1" DR, 1-11/16"	1	E	3	4
SOCKET, SOCKET WRENCH, 1" DR, 1-13/16"	1	E	3	5
SOCKET, SOCKET WRENCH, 1" DR, 1-5/8"	1	E	3	3
SOCKET, SOCKET WRENCH, 1" DR, 1-7/8"	1	E	3	6
SOCKET, SOCKET WRENCH, 1" DR, 2"	1	E	3	7
SOCKET, SOCKET WRENCH, 1" DR, 2-1/2"	1	E	3	18
SOCKET, SOCKET WRENCH, 1" DR, 2-1/4"	1	E	3	16
SOCKET, SOCKET WRENCH, 1" DR, 2-1/8"	1	E	3	14
SOCKET, SOCKET WRENCH, 1" DR, 2-3/16"	1	E	3	15
SOCKET, SOCKET WRENCH, 1" DR, 2-3/4"	1	E	3	9
SOCKET, SOCKET WRENCH, 1" DR, 2-3/8"	1	E	3	17
SOCKET, SOCKET WRENCH, 1" DR, 2-5/8"	1	E	3	8

TM 9-4910-783-13&P

SATS FIELD MAINTENANCE MODULE #1 (FMM1) COMPONENT LIST

0059 00

NOMENCLATURE	QTY	RACK	DRAWER	LOCATION
SOCKET, SOCKET WRENCH, 1" DR, 2-9/16"	1	E	3	12
SOCKET, SOCKET WRENCH, 1" DR, 2-13/16"	1	E	3	13
SOCKET, SOCKET WRENCH, 1" DR, 3"	1	E	3	10
SOCKET, SOCKET WRENCH, 1" DR, 3-1/8"	1	E	3	11
SOCKET, SOCKET WRENCH, 1/2" DR, 12 PT, DEEP, 10MM	1	F	9	95
SOCKET, SOCKET WRENCH, 1/2" DR, 12 PT, DEEP, 10MM	1	F	11	95
SOCKET, SOCKET WRENCH, 1/2" DR, 12 PT, DEEP, 11MM	1	F	9	94
SOCKET, SOCKET WRENCH, 1/2" DR, 12 PT, DEEP, 11MM	1	F	11	94
SOCKET, SOCKET WRENCH, 1/2" DR, 12 PT, DEEP, 12MM	1	F	9	93
SOCKET, SOCKET WRENCH, 1/2" DR, 12 PT, DEEP, 12MM	1	F	11	93
SOCKET, SOCKET WRENCH, 1/2" DR, 12 PT, DEEP, 13MM	1	F	9	92
SOCKET, SOCKET WRENCH, 1/2" DR, 12 PT, DEEP, 13MM	1	F	11	92
SOCKET, SOCKET WRENCH, 1/2" DR, 12 PT, DEEP, 14MM	1	F	9	91
SOCKET, SOCKET WRENCH, 1/2" DR, 12 PT, DEEP, 14MM	1	F	11	91
SOCKET, SOCKET WRENCH, 1/2" DR, 12 PT, DEEP, 15MM	1	F	9	90
SOCKET, SOCKET WRENCH, 1/2" DR, 12 PT, DEEP, 15MM	1	F	11	90
SOCKET, SOCKET WRENCH, 1/2" DR, 12 PT, DEEP, 16MM	1	F	9	89
SOCKET, SOCKET WRENCH, 1/2" DR, 12 PT, DEEP, 16MM	1	F	11	89
SOCKET, SOCKET WRENCH, 1/2" DR, 12 PT, DEEP, 17MM	1	F	9	88
SOCKET, SOCKET WRENCH, 1/2" DR, 12 PT, DEEP, 17MM	1	F	11	88
SOCKET, SOCKET WRENCH, 1/2" DR, 12 PT, DEEP, 18MM	1	F	9	87
SOCKET, SOCKET WRENCH, 1/2" DR, 12 PT, DEEP, 18MM	1	F	11	87
SOCKET, SOCKET WRENCH, 1/2" DR, 12 PT, DEEP, 19MM	1	F	9	86
SOCKET, SOCKET WRENCH, 1/2" DR, 12 PT, DEEP, 19MM	1	F	11	86
SOCKET, SOCKET WRENCH, 1/2" DR, 12 PT, DEEP, 20MM	1	F	9	98
SOCKET, SOCKET WRENCH, 1/2" DR, 12 PT, DEEP, 20MM	1	F	11	98
SOCKET, SOCKET WRENCH, 1/2" DR, 12 PT, DEEP, 21MM	1	F	9	99
SOCKET, SOCKET WRENCH, 1/2" DR, 12 PT, DEEP, 21MM	1	F	11	99
SOCKET, SOCKET WRENCH, 1/2" DR, 12 PT, DEEP, 22MM	1	F	9	100
SOCKET, SOCKET WRENCH, 1/2" DR, 12 PT, DEEP, 22MM	1	F	11	100
SOCKET, SOCKET WRENCH, 1/2" DR, 12 PT, DEEP, 23MM	1	F	9	101
SOCKET, SOCKET WRENCH, 1/2" DR, 12 PT, DEEP, 23MM	1	F	11	101
SOCKET, SOCKET WRENCH, 1/2" DR, 12 PT, DEEP, 24MM	1	F	9	102
SOCKET, SOCKET WRENCH, 1/2" DR, 12 PT, DEEP, 24MM	1	F	11	102
SOCKET, SOCKET WRENCH, 1/2" DR, 12 PT, DEEP, 25MM	1	F	9	103
SOCKET, SOCKET WRENCH, 1/2" DR, 12 PT, DEEP, 25MM	1	F	11	103
SOCKET, SOCKET WRENCH, 1/2" DR, 12 PT, DEEP, 26MM	1	F	9	104

TM 9-4910-783-13&P

SATS FIELD MAINTENANCE MODULE #1 (FMM1) COMPONENT LIST

0059 00

NOMENCLATURE	QTY	RACK	DRAWER	LOCATION
SOCKET, SOCKET WRENCH, 1/2" DR, 12 PT, DEEP, 26MM	1	F	11	104
SOCKET, SOCKET WRENCH, 1/2" DR, 12 PT, DEEP, 27MM	1	F	9	105
SOCKET, SOCKET WRENCH, 1/2" DR, 12 PT, DEEP, 27MM	1	F	11	105
SOCKET, SOCKET WRENCH, 1/2" DR, 12 PT, DEEP, 28MM	1	F	9	106
SOCKET, SOCKET WRENCH, 1/2" DR, 12 PT, DEEP, 28MM	1	F	11	106
SOCKET, SOCKET WRENCH, 1/2" DR, 12 PT, DEEP, 29MM	1	F	9	107
SOCKET, SOCKET WRENCH, 1/2" DR, 12 PT, DEEP, 29MM	1	F	11	107
SOCKET, SOCKET WRENCH, 1/2" DR, 12 PT, DEEP, 30MM	1	F	9	108
SOCKET, SOCKET WRENCH, 1/2" DR, 12 PT, DEEP, 30MM	1	F	11	108
SOCKET, SOCKET WRENCH, 1/2" DR, 12 PT, DEEP, 32MM	1	F	9	109
SOCKET, SOCKET WRENCH, 1/2" DR, 12 PT, DEEP, 32MM	1	F	11	109
SOCKET, SOCKET WRENCH, 1/2" DR, 12 PT, REGULAR, 19/32"	1	F	9	83
SOCKET, SOCKET WRENCH, 1/2" DR, 12 PT, REGULAR, 19/32"	1	F	11	83
SOCKET, SOCKET WRENCH, 1/2" DR, 12 PT, REGULAR, 21/32"	1	F	9	70
SOCKET, SOCKET WRENCH, 1/2" DR, 12 PT, REGULAR, 21/32"	1	F	11	70
SOCKET, SOCKET WRENCH, 1/2" DR, 12 PT, REGULAR, 25/32"	1	F	9	59
SOCKET, SOCKET WRENCH, 1/2" DR, 12 PT, REGULAR, 25/32"	1	F	11	59
SOCKET, SOCKET WRENCH, 1/2" DR, 6 PT, DEEP, 1"	1	F	8	115
SOCKET, SOCKET WRENCH, 1/2" DR, 6 PT, DEEP, 1"	1	F	10	115
SOCKET, SOCKET WRENCH, 1/2" DR, 6 PT, DEEP, 1/2"	1	F	8	82
SOCKET, SOCKET WRENCH, 1/2" DR, 6 PT, DEEP, 1/2"	1	F	10	82
SOCKET, SOCKET WRENCH, 1/2" DR, 6 PT, DEEP, 11/16"	1	F	8	85
SOCKET, SOCKET WRENCH, 1/2" DR, 6 PT, DEEP, 11/16"	1	F	10	85
SOCKET, SOCKET WRENCH, 1/2" DR, 6 PT, DEEP, 1-1/16"	1	F	8	114
SOCKET, SOCKET WRENCH, 1/2" DR, 6 PT, DEEP, 1-1/16"	1	F	10	114
SOCKET, SOCKET WRENCH, 1/2" DR, 6 PT, DEEP, 1-1/2"	1	F	8	107
SOCKET, SOCKET WRENCH, 1/2" DR, 6 PT, DEEP, 1-1/2"	1	F	10	107
SOCKET, SOCKET WRENCH, 1/2" DR, 6 PT, DEEP, 1-1/4"	1	F	8	111
SOCKET, SOCKET WRENCH, 1/2" DR, 6 PT, DEEP, 1-1/4"	1	F	10	111
SOCKET, SOCKET WRENCH, 1/2" DR, 6 PT, DEEP, 1-1/8"	1	F	8	113
SOCKET, SOCKET WRENCH, 1/2" DR, 6 PT, DEEP, 1-1/8"	1	F	10	113
SOCKET, SOCKET WRENCH, 1/2" DR, 6 PT, DEEP, 13/16"	1	F	8	87
SOCKET, SOCKET WRENCH, 1/2" DR, 6 PT, DEEP, 13/16"	1	F	10	87
SOCKET, SOCKET WRENCH, 1/2" DR, 6 PT, DEEP, 1-3/16"	1	F	8	112
SOCKET, SOCKET WRENCH, 1/2" DR, 6 PT, DEEP, 1-3/16"	1	F	10	112
SOCKET, SOCKET WRENCH, 1/2" DR, 6 PT, DEEP, 1-3/8"	1	F	8	109
SOCKET, SOCKET WRENCH, 1/2" DR, 6 PT, DEEP, 1-3/8"	1	F	10	109

TM 9-4910-783-13&P

SATS FIELD MAINTENANCE MODULE #1 (FMM1) COMPONENT LIST

0059 00

NOMENCLATURE	QTY	RACK	DRAWER	LOCATION
SOCKET, SOCKET WRENCH, 1/2" DR, 6 PT, DEEP, 15/16"	1	F	8	116
SOCKET, SOCKET WRENCH, 1/2" DR, 6 PT, DEEP, 15/16"	1	F	10	116
SOCKET, SOCKET WRENCH, 1/2" DR, 6 PT, DEEP, 1-5/16"	1	F	8	110
SOCKET, SOCKET WRENCH, 1/2" DR, 6 PT, DEEP, 1-5/16"	1	F	10	110
SOCKET, SOCKET WRENCH, 1/2" DR, 6 PT, DEEP, 1-7/16"	1	F	8	108
SOCKET, SOCKET WRENCH, 1/2" DR, 6 PT, DEEP, 1-7/16"	1	F	10	108
SOCKET, SOCKET WRENCH, 1/2" DR, 6 PT, DEEP, 3/4"	1	F	8	86
SOCKET, SOCKET WRENCH, 1/2" DR, 6 PT, DEEP, 3/4"	1	F	10	86
SOCKET, SOCKET WRENCH, 1/2" DR, 6 PT, DEEP, 3/8"	1	F	8	80
SOCKET, SOCKET WRENCH, 1/2" DR, 6 PT, DEEP, 3/8"	1	F	10	80
SOCKET, SOCKET WRENCH, 1/2" DR, 6 PT, DEEP, 5/8"	1	F	8	84
SOCKET, SOCKET WRENCH, 1/2" DR, 6 PT, DEEP, 5/8"	1	F	10	84
SOCKET, SOCKET WRENCH, 1/2" DR, 6 PT, DEEP, 7/16"	1	F	8	81
SOCKET, SOCKET WRENCH, 1/2" DR, 6 PT, DEEP, 7/16"	1	F	10	81
SOCKET, SOCKET WRENCH, 1/2" DR, 6 PT, DEEP, 7/8"	1	F	8	88
SOCKET, SOCKET WRENCH, 1/2" DR, 6 PT, DEEP, 7/8"	1	F	10	88
SOCKET, SOCKET WRENCH, 1/2" DR, 6 PT, DEEP, 9/16"	1	F	8	83
SOCKET, SOCKET WRENCH, 1/2" DR, 6 PT, DEEP, 9/16"	1	F	10	83
SOCKET, SOCKET WRENCH, 1/2" DR, 6 PT, REGULAR, 1"	1	F	8	98
SOCKET, SOCKET WRENCH, 1/2" DR, 6 PT, REGULAR, 1"	1	F	10	98
SOCKET, SOCKET WRENCH, 1/2" DR, 6 PT, REGULAR, 1/2"	1	F	8	94
SOCKET, SOCKET WRENCH, 1/2" DR, 6 PT, REGULAR, 1/2"	1	F	10	94
SOCKET, SOCKET WRENCH, 1/2" DR, 6 PT, REGULAR, 10MM	1	F	9	85
SOCKET, SOCKET WRENCH, 1/2" DR, 6 PT, REGULAR, 10MM	1	F	11	85
SOCKET, SOCKET WRENCH, 1/2" DR, 6 PT, REGULAR, 11/16"	1	F	8	91
SOCKET, SOCKET WRENCH, 1/2" DR, 6 PT, REGULAR, 11/16"	1	F	10	91
SOCKET, SOCKET WRENCH, 1/2" DR, 6 PT, REGULAR, 1-1/16"	1	F	8	99
SOCKET, SOCKET WRENCH, 1/2" DR, 6 PT, REGULAR, 1-1/16"	1	F	10	99
SOCKET, SOCKET WRENCH, 1/2" DR, 6 PT, REGULAR, 1-1/2"	1	F	8	106
SOCKET, SOCKET WRENCH, 1/2" DR, 6 PT, REGULAR, 1-1/2"	1	F	10	106
SOCKET, SOCKET WRENCH, 1/2" DR, 6 PT, REGULAR, 1-1/4"	1	F	8	102
SOCKET, SOCKET WRENCH, 1/2" DR, 6 PT, REGULAR, 1-1/4"	1	F	10	102
SOCKET, SOCKET WRENCH, 1/2" DR, 6 PT, REGULAR, 1-1/8"	1	F	8	100
SOCKET, SOCKET WRENCH, 1/2" DR, 6 PT, REGULAR, 1-1/8"	1	F	10	100
SOCKET, SOCKET WRENCH, 1/2" DR, 6 PT, REGULAR, 11MM	1	F	9	82
SOCKET, SOCKET WRENCH, 1/2" DR, 6 PT, REGULAR, 11MM	1	F	11	82
SOCKET, SOCKET WRENCH, 1/2" DR, 6 PT, REGULAR, 12MM	1	F	9	81

TM 9-4910-783-13&P

SATS FIELD MAINTENANCE MODULE #1 (FMM1) COMPONENT LIST

0059 00

NOMENCLATURE	QTY	RACK	DRAWER	LOCATION
SOCKET, SOCKET WRENCH, 1/2" DR, 6 PT, REGULAR, 12MM	1	F	11	81
SOCKET, SOCKET WRENCH, 1/2" DR, 6 PT, REGULAR, 13/16"	1	F	8	89
SOCKET, SOCKET WRENCH, 1/2" DR, 6 PT, REGULAR, 13/16"	1	F	10	89
SOCKET, SOCKET WRENCH, 1/2" DR, 6 PT, REGULAR, 1-3/16"	1	F	8	101
SOCKET, SOCKET WRENCH, 1/2" DR, 6 PT, REGULAR, 1-3/16"	1	F	10	101
SOCKET, SOCKET WRENCH, 1/2" DR, 6 PT, REGULAR, 1-3/8"	1	F	8	104
SOCKET, SOCKET WRENCH, 1/2" DR, 6 PT, REGULAR, 1-3/8"	1	F	10	104
SOCKET, SOCKET WRENCH, 1/2" DR, 6 PT, REGULAR, 13MM	1	F	9	80
SOCKET, SOCKET WRENCH, 1/2" DR, 6 PT, REGULAR, 13MM	1	F	11	80
SOCKET, SOCKET WRENCH, 1/2" DR, 6 PT, REGULAR, 14MM	1	F	9	79
SOCKET, SOCKET WRENCH, 1/2" DR, 6 PT, REGULAR, 14MM	1	F	11	79
SOCKET, SOCKET WRENCH, 1/2" DR, 6 PT, REGULAR, 15/16"	1	F	8	97
SOCKET, SOCKET WRENCH, 1/2" DR, 6 PT, REGULAR, 15/16"	1	F	10	97
SOCKET, SOCKET WRENCH, 1/2" DR, 6 PT, REGULAR, 15MM	1	F	9	78
SOCKET, SOCKET WRENCH, 1/2" DR, 6 PT, REGULAR, 15MM	1	F	11	78
SOCKET, SOCKET WRENCH, 1/2" DR, 6 PT, REGULAR, 16MM	1	F	9	77
SOCKET, SOCKET WRENCH, 1/2" DR, 6 PT, REGULAR, 16MM	1	F	11	77
SOCKET, SOCKET WRENCH, 1/2" DR, 6 PT, REGULAR, 1-7/16"	1	F	8	105
SOCKET, SOCKET WRENCH, 1/2" DR, 6 PT, REGULAR, 1-7/16"	1	F	10	105
SOCKET, SOCKET WRENCH, 1/2" DR, 6 PT, REGULAR, 17MM	1	F	9	76
SOCKET, SOCKET WRENCH, 1/2" DR, 6 PT, REGULAR, 17MM	1	F	11	76
SOCKET, SOCKET WRENCH, 1/2" DR, 6 PT, REGULAR, 18MM	1	F	9	75
SOCKET, SOCKET WRENCH, 1/2" DR, 6 PT, REGULAR, 18MM	1	F	11	75
SOCKET, SOCKET WRENCH, 1/2" DR, 6 PT, REGULAR, 19MM	1	F	9	74
SOCKET, SOCKET WRENCH, 1/2" DR, 6 PT, REGULAR, 19MM	1	F	11	74
SOCKET, SOCKET WRENCH, 1/2" DR, 6 PT, REGULAR, 21MM	1	F	9	73
SOCKET, SOCKET WRENCH, 1/2" DR, 6 PT, REGULAR, 21MM	1	F	11	73
SOCKET, SOCKET WRENCH, 1/2" DR, 6 PT, REGULAR, 22MM	1	F	9	72
SOCKET, SOCKET WRENCH, 1/2" DR, 6 PT, REGULAR, 22MM	1	F	11	72
SOCKET, SOCKET WRENCH, 1/2" DR, 6 PT, REGULAR, 23MM	1	F	9	71
SOCKET, SOCKET WRENCH, 1/2" DR, 6 PT, REGULAR, 23MM	1	F	11	71
SOCKET, SOCKET WRENCH, 1/2" DR, 6 PT, REGULAR, 24MM	1	F	9	60
SOCKET, SOCKET WRENCH, 1/2" DR, 6 PT, REGULAR, 24MM	1	F	11	60
SOCKET, SOCKET WRENCH, 1/2" DR, 6 PT, REGULAR, 25MM	1	F	9	61
SOCKET, SOCKET WRENCH, 1/2" DR, 6 PT, REGULAR, 25MM	1	F	11	61
SOCKET, SOCKET WRENCH, 1/2" DR, 6 PT, REGULAR, 26MM	1	F	9	62
SOCKET, SOCKET WRENCH, 1/2" DR, 6 PT, REGULAR, 26MM	1	F	11	62

TM 9-4910-783-13&P

SATS FIELD MAINTENANCE MODULE #1 (FMM1) COMPONENT LIST

0059 00

NOMENCLATURE	QTY	RACK	DRAWER	LOCATION
SOCKET, SOCKET WRENCH, 1/2" DR, 6 PT, REGULAR, 27MM	1	F	9	63
SOCKET, SOCKET WRENCH, 1/2" DR, 6 PT, REGULAR, 27MM	1	F	11	63
SOCKET, SOCKET WRENCH, 1/2" DR, 6 PT, REGULAR, 28MM	1	F	9	64
SOCKET, SOCKET WRENCH, 1/2" DR, 6 PT, REGULAR, 28MM	1	F	11	64
SOCKET, SOCKET WRENCH, 1/2" DR, 6 PT, REGULAR, 29MM	1	F	9	65
SOCKET, SOCKET WRENCH, 1/2" DR, 6 PT, REGULAR, 29MM	1	F	11	65
SOCKET, SOCKET WRENCH, 1/2" DR, 6 PT, REGULAR, 3/4"	1	F	8	90
SOCKET, SOCKET WRENCH, 1/2" DR, 6 PT, REGULAR, 3/4"	1	F	10	90
SOCKET, SOCKET WRENCH, 1/2" DR, 6 PT, REGULAR, 3/8"	1	F	8	79
SOCKET, SOCKET WRENCH, 1/2" DR, 6 PT, REGULAR, 3/8"	1	F	10	79
SOCKET, SOCKET WRENCH, 1/2" DR, 6 PT, REGULAR, 30MM	1	F	9	66
SOCKET, SOCKET WRENCH, 1/2" DR, 6 PT, REGULAR, 30MM	1	F	11	66
SOCKET, SOCKET WRENCH, 1/2" DR, 6 PT, REGULAR, 32MM	1	F	9	67
SOCKET, SOCKET WRENCH, 1/2" DR, 6 PT, REGULAR, 32MM	1	F	11	67
SOCKET, SOCKET WRENCH, 1/2" DR, 6 PT, REGULAR, 36MM	1	F	9	68
SOCKET, SOCKET WRENCH, 1/2" DR, 6 PT, REGULAR, 36MM	1	F	11	68
SOCKET, SOCKET WRENCH, 1/2" DR, 6 PT, REGULAR, 5/8"	1	F	8	92
SOCKET, SOCKET WRENCH, 1/2" DR, 6 PT, REGULAR, 5/8"	1	F	10	92
SOCKET, SOCKET WRENCH, 1/2" DR, 6 PT, REGULAR, 7/16"	1	F	8	95
SOCKET, SOCKET WRENCH, 1/2" DR, 6 PT, REGULAR, 7/16"	1	F	10	95
SOCKET, SOCKET WRENCH, 1/2" DR, 6 PT, REGULAR, 7/8"	1	F	8	96
SOCKET, SOCKET WRENCH, 1/2" DR, 6 PT, REGULAR, 7/8"	1	F	10	96
SOCKET, SOCKET WRENCH, 1/2" DR, 6 PT, REGULAR, 9/16"	1	F	8	93
SOCKET, SOCKET WRENCH, 1/2" DR, 6 PT, REGULAR, 9/16"	1	F	10	93
SOCKET, SOCKET WRENCH, 1/2" DR, 6 PT, REGULAR, 9MM	1	F	9	84
SOCKET, SOCKET WRENCH, 1/2" DR, 6 PT, REGULAR, 9MM	1	F	11	84
SOCKET, SOCKET WRENCH, 1/2" DR, 6 PT, REGULAR, 1-5/16"	1	F	8	103
SOCKET, SOCKET WRENCH, 1/2" DR, 6 PT, REGULAR, 1-5/16"	1	F	10	103
SOCKET, SOCKET WRENCH, 1/4" DR, 6 PT, DEEP, 1/2"	1	F	9	31
SOCKET, SOCKET WRENCH, 1/4" DR, 6 PT, DEEP, 1/2"	1	F	11	31
SOCKET, SOCKET WRENCH, 1/4" DR, 6 PT, DEEP, 1/4"	1	F	9	25
SOCKET, SOCKET WRENCH, 1/4" DR, 6 PT, DEEP, 1/8"	1	F	9	21
SOCKET, SOCKET WRENCH, 1/4" DR, 6 PT, DEEP, 1/8"	1	F	11	21
SOCKET, SOCKET WRENCH, 1/4" DR, 6 PT, DEEP, 10MM	1	F	9	9
SOCKET, SOCKET WRENCH, 1/4" DR, 6 PT, DEEP, 10MM	1	F	11	9
SOCKET, SOCKET WRENCH, 1/4" DR, 6 PT, DEEP, 11/32"	1	F	9	28
SOCKET, SOCKET WRENCH, 1/4" DR, 6 PT, DEEP, 11/32"	1	F	11	28

TM 9-4910-783-13&P

SATS FIELD MAINTENANCE MODULE #1 (FMM1) COMPONENT LIST

0059 00

NOMENCLATURE	QTY	RACK	DRAWER	LOCATION
SOCKET, SOCKET WRENCH, 1/4" DR, 6 PT, DEEP, 11MM	1	F	9	10
SOCKET, SOCKET WRENCH, 1/4" DR, 6 PT, DEEP, 11MM	1	F	11	10
SOCKET, SOCKET WRENCH, 1/4" DR, 6 PT, DEEP, 12MM	1	F	9	11
SOCKET, SOCKET WRENCH, 1/4" DR, 6 PT, DEEP, 12MM	1	F	11	11
SOCKET, SOCKET WRENCH, 1/4" DR, 6 PT, DEEP, 13MM	1	F	9	12
SOCKET, SOCKET WRENCH, 1/4" DR, 6 PT, DEEP, 13MM	1	F	11	12
SOCKET, SOCKET WRENCH, 1/4" DR, 6 PT, DEEP, 14MM	1	F	9	13
SOCKET, SOCKET WRENCH, 1/4" DR, 6 PT, DEEP, 14MM	1	F	11	13
SOCKET, SOCKET WRENCH, 1/4" DR, 6 PT, DEEP, 15MM	1	F	9	14
SOCKET, SOCKET WRENCH, 1/4" DR, 6 PT, DEEP, 15MM	1	F	11	14
SOCKET, SOCKET WRENCH, 1/4" DR, 6 PT, DEEP, 3/16"	1	F	9	23
SOCKET, SOCKET WRENCH, 1/4" DR, 6 PT, DEEP, 3/16"	1	F	11	23
SOCKET, SOCKET WRENCH, 1/4" DR, 6 PT, DEEP, 3/8"	1	F	9	29
SOCKET, SOCKET WRENCH, 1/4" DR, 6 PT, DEEP, 3/8"	1	F	11	29
SOCKET, SOCKET WRENCH, 1/4" DR, 6 PT, DEEP, 4.5MM	1	F	9	2
SOCKET, SOCKET WRENCH, 1/4" DR, 6 PT, DEEP, 4.5MM	1	F	11	2
SOCKET, SOCKET WRENCH, 1/4" DR, 6 PT, DEEP, 4MM	1	F	9	1
SOCKET, SOCKET WRENCH, 1/4" DR, 6 PT, DEEP, 4MM	1	F	11	1
SOCKET, SOCKET WRENCH, 1/4" DR, 6 PT, DEEP, 5.5MM	1	F	9	4
SOCKET, SOCKET WRENCH, 1/4" DR, 6 PT, DEEP, 5.5MM	1	F	11	4
SOCKET, SOCKET WRENCH, 1/4" DR, 6 PT, DEEP, 5/16"	1	F	9	27
SOCKET, SOCKET WRENCH, 1/4" DR, 6 PT, DEEP, 5/16"	1	F	11	27
SOCKET, SOCKET WRENCH, 1/4" DR, 6 PT, DEEP, 5/32"	1	F	9	22
SOCKET, SOCKET WRENCH, 1/4" DR, 6 PT, DEEP, 5/32"	1	F	11	22
SOCKET, SOCKET WRENCH, 1/4" DR, 6 PT, DEEP, 5MM	1	F	9	3
SOCKET, SOCKET WRENCH, 1/4" DR, 6 PT, DEEP, 5MM	1	F	11	3
SOCKET, SOCKET WRENCH, 1/4" DR, 6 PT, DEEP, 6MM	1	F	9	5
SOCKET, SOCKET WRENCH, 1/4" DR, 6 PT, DEEP, 6MM	1	F	11	5
SOCKET, SOCKET WRENCH, 1/4" DR, 6 PT, DEEP, 7/16"	1	F	9	30
SOCKET, SOCKET WRENCH, 1/4" DR, 6 PT, DEEP, 7/16"	1	F	11	30
SOCKET, SOCKET WRENCH, 1/4" DR, 6 PT, DEEP, 7/32"	1	F	9	24
SOCKET, SOCKET WRENCH, 1/4" DR, 6 PT, DEEP, 7/32"	1	F	11	24
SOCKET, SOCKET WRENCH, 1/4" DR, 6 PT, DEEP, 7MM	1	F	9	6
SOCKET, SOCKET WRENCH, 1/4" DR, 6 PT, DEEP, 7MM	1	F	11	6
SOCKET, SOCKET WRENCH, 1/4" DR, 6 PT, DEEP, 8MM	1	F	9	7
SOCKET, SOCKET WRENCH, 1/4" DR, 6 PT, DEEP, 8MM	1	F	11	7
SOCKET, SOCKET WRENCH, 1/4" DR, 6 PT, DEEP, 9/16"	1	F	9	32

TM 9-4910-783-13&P

SATS FIELD MAINTENANCE MODULE #1 (FMM1) COMPONENT LIST

0059 00

NOMENCLATURE	QTY	RACK	DRAWER	LOCATION
SOCKET, SOCKET WRENCH, 1/4" DR, 6 PT, DEEP, 9/16"	1	F	11	32
SOCKET, SOCKET WRENCH, 1/4" DR, 6 PT, DEEP, 9/32"	1	F	9	26
SOCKET, SOCKET WRENCH, 1/4" DR, 6 PT, DEEP, 9/32"	1	F	11	26
SOCKET, SOCKET WRENCH, 1/4" DR, 6 PT, DEEP, 9MM	1	F	9	8
SOCKET, SOCKET WRENCH, 1/4" DR, 6 PT, DEEP, 9MM	1	F	11	8
SOCKET, SOCKET WRENCH, 1/4" DR, 6 PT, REGULAR, 1/2"	1	F	9	34
SOCKET, SOCKET WRENCH, 1/4" DR, 6 PT, REGULAR, 1/2"	1	F	11	34
SOCKET, SOCKET WRENCH, 1/4" DR, 6 PT, REGULAR, 1/4"	1	F	9	40
SOCKET, SOCKET WRENCH, 1/4" DR, 6 PT, REGULAR, 1/4"	1	F	11	40
SOCKET, SOCKET WRENCH, 1/4" DR, 6 PT, REGULAR, 1/8"	1	F	9	44
SOCKET, SOCKET WRENCH, 1/4" DR, 6 PT, REGULAR, 1/8"	1	F	11	44
SOCKET, SOCKET WRENCH, 1/4" DR, 6 PT, REGULAR, 10MM	1	F	9	53
SOCKET, SOCKET WRENCH, 1/4" DR, 6 PT, REGULAR, 10MM	1	F	11	53
SOCKET, SOCKET WRENCH, 1/4" DR, 6 PT, REGULAR, 11/32"	1	F	9	37
SOCKET, SOCKET WRENCH, 1/4" DR, 6 PT, REGULAR, 11/32"	1	F	11	37
SOCKET, SOCKET WRENCH, 1/4" DR, 6 PT, REGULAR, 11MM	1	F	9	54
SOCKET, SOCKET WRENCH, 1/4" DR, 6 PT, REGULAR, 11MM	1	F	11	54
SOCKET, SOCKET WRENCH, 1/4" DR, 6 PT, REGULAR, 12MM	1	F	9	55
SOCKET, SOCKET WRENCH, 1/4" DR, 6 PT, REGULAR, 12MM	1	F	11	55
SOCKET, SOCKET WRENCH, 1/4" DR, 6 PT, REGULAR, 13MM	1	F	9	56
SOCKET, SOCKET WRENCH, 1/4" DR, 6 PT, REGULAR, 13MM	1	F	11	56
SOCKET, SOCKET WRENCH, 1/4" DR, 6 PT, REGULAR, 14MM	1	F	9	57
SOCKET, SOCKET WRENCH, 1/4" DR, 6 PT, REGULAR, 14MM	1	F	11	57
SOCKET, SOCKET WRENCH, 1/4" DR, 6 PT, REGULAR, 15MM	1	F	9	58
SOCKET, SOCKET WRENCH, 1/4" DR, 6 PT, REGULAR, 15MM	1	F	11	58
SOCKET, SOCKET WRENCH, 1/4" DR, 6 PT, REGULAR, 3/16"	1	F	9	42
SOCKET, SOCKET WRENCH, 1/4" DR, 6 PT, REGULAR, 3/16"	1	F	11	42
SOCKET, SOCKET WRENCH, 1/4" DR, 6 PT, REGULAR, 3/8"	1	F	9	36
SOCKET, SOCKET WRENCH, 1/4" DR, 6 PT, REGULAR, 3/8"	1	F	11	36
SOCKET, SOCKET WRENCH, 1/4" DR, 6 PT, REGULAR, 4.5MM	1	F	9	51
SOCKET, SOCKET WRENCH, 1/4" DR, 6 PT, REGULAR, 4.5MM	1	F	11	51
SOCKET, SOCKET WRENCH, 1/4" DR, 6 PT, REGULAR, 4MM	1	F	9	52
SOCKET, SOCKET WRENCH, 1/4" DR, 6 PT, REGULAR, 4MM	1	F	11	52
SOCKET, SOCKET WRENCH, 1/4" DR, 6 PT, REGULAR, 5.5MM	1	F	9	49
SOCKET, SOCKET WRENCH, 1/4" DR, 6 PT, REGULAR, 5.5MM	1	F	11	49
SOCKET, SOCKET WRENCH, 1/4" DR, 6 PT, REGULAR, 5/16"	1	F	9	38
SOCKET, SOCKET WRENCH, 1/4" DR, 6 PT, REGULAR, 5/16"	1	F	11	38

TM 9-4910-783-13&P

SATS FIELD MAINTENANCE MODULE #1 (FMM1) COMPONENT LIST

0059 00

NOMENCLATURE	QTY	RACK	DRAWER	LOCATION
SOCKET, SOCKET WRENCH, 1/4" DR, 6 PT, REGULAR, 5/32"	1	F	9	43
SOCKET, SOCKET WRENCH, 1/4" DR, 6 PT, REGULAR, 5/32"	1	F	11	43
SOCKET, SOCKET WRENCH, 1/4" DR, 6 PT, REGULAR, 5MM	1	F	9	50
SOCKET, SOCKET WRENCH, 1/4" DR, 6 PT, REGULAR, 5MM	1	F	11	50
SOCKET, SOCKET WRENCH, 1/4" DR, 6 PT, REGULAR, 6MM	1	F	9	48
SOCKET, SOCKET WRENCH, 1/4" DR, 6 PT, REGULAR, 6MM	1	F	11	48
SOCKET, SOCKET WRENCH, 1/4" DR, 6 PT, REGULAR, 7/16"	1	F	9	35
SOCKET, SOCKET WRENCH, 1/4" DR, 6 PT, REGULAR, 7/16"	1	F	11	35
SOCKET, SOCKET WRENCH, 1/4" DR, 6 PT, REGULAR, 7/32"	1	F	9	41
SOCKET, SOCKET WRENCH, 1/4" DR, 6 PT, REGULAR, 7/32"	1	F	11	41
SOCKET, SOCKET WRENCH, 1/4" DR, 6 PT, REGULAR, 7MM	1	F	9	47
SOCKET, SOCKET WRENCH, 1/4" DR, 6 PT, REGULAR, 7MM	1	F	11	47
SOCKET, SOCKET WRENCH, 1/4" DR, 6 PT, REGULAR, 8MM	1	F	9	46
SOCKET, SOCKET WRENCH, 1/4" DR, 6 PT, REGULAR, 8MM	1	F	11	46
SOCKET, SOCKET WRENCH, 1/4" DR, 6 PT, REGULAR, 9/16"	1	F	9	33
SOCKET, SOCKET WRENCH, 1/4" DR, 6 PT, REGULAR, 9/16"	1	F	11	33
SOCKET, SOCKET WRENCH, 1/4" DR, 6 PT, REGULAR, 9/32"	1	F	9	39
SOCKET, SOCKET WRENCH, 1/4" DR, 6 PT, REGULAR, 9/32"	1	F	11	39
SOCKET, SOCKET WRENCH, 1/4" DR, 6 PT, REGULAR, 9MM	1	F	9	45
SOCKET, SOCKET WRENCH, 1/4" DR, 6 PT, REGULAR, 9MM	1	F	11	45
SOCKET, SOCKET WRENCH, 3/4" DR, 12 PT, 1-1/16"	1	E	1	4
SOCKET, SOCKET WRENCH, 3/4" DR, 12 PT, 1-1/2"	1	E	1	21
SOCKET, SOCKET WRENCH, 3/4" DR, 12 PT, 1-1/4"	1	E	1	13
SOCKET, SOCKET WRENCH, 3/4" DR, 12 PT, 1-1/8"	1	E	1	12
SOCKET, SOCKET WRENCH, 3/4" DR, 12 PT, 1-13/16"	1	E	1	22
SOCKET, SOCKET WRENCH, 3/4" DR, 12 PT, 1-3/4"	1	E	1	17
SOCKET, SOCKET WRENCH, 3/4" DR, 12 PT, 1-3/8"	1	E	1	15
SOCKET, SOCKET WRENCH, 3/4" DR, 12 PT, 1-5/16"	1	E	1	14
SOCKET, SOCKET WRENCH, 3/4" DR, 12 PT, 1-5/8"	1	E	1	19
SOCKET, SOCKET WRENCH, 3/4" DR, 12 PT, 1-7/16"	1	E	1	16
SOCKET, SOCKET WRENCH, 3/4" DR, 12 PT, 1-7/8"	1	E	1	23
SOCKET, SOCKET WRENCH, 3/4" DR, 12 PT, 1-9/16"	1	E	1	20
SOCKET, SOCKET WRENCH, 3/4" DR, 12 PT, 1"	1	E	1	5
SOCKET, SOCKET WRENCH, 3/4" DR, 12 PT, 15/16"	1	E	1	6
SOCKET, SOCKET WRENCH, 3/4" DR, 12 PT, 2-1/16"	1	E	1	25
SOCKET, SOCKET WRENCH, 3/4" DR, 12 PT, 2-1/4"	1	E	1	28
SOCKET, SOCKET WRENCH, 3/4" DR, 12 PT, 2-1/8"	1	E	1	26

TM 9-4910-783-13&P

SATS FIELD MAINTENANCE MODULE #1 (FMM1) COMPONENT LIST

0059 00

NOMENCLATURE	QTY	RACK	DRAWER	LOCATION
SOCKET, SOCKET WRENCH, 3/4" DR, 12 PT, 2-3/16"	1	E	1	27
SOCKET, SOCKET WRENCH, 3/4" DR, 12 PT, 2-3/8"	1	E	1	29
SOCKET, SOCKET WRENCH, 3/4" DR, 12 PT, 2"	1	E	1	24
SOCKET, SOCKET WRENCH, 3/4" DR, 12 PT, 7/8"	1	E	1	7
SOCKET, SOCKET WRENCH, 3/4" DR, 12 PT, 1-11/16"	1	E	1	18
SOCKET, SOCKET WRENCH, 3/8" DR, 6 PT, DEEP, 1"	1	F	8	22
SOCKET, SOCKET WRENCH, 3/8" DR, 6 PT, DEEP, 1"	1	F	10	22
SOCKET, SOCKET WRENCH, 3/8" DR, 6 PT, DEEP, 1/2"	1	F	8	30
SOCKET, SOCKET WRENCH, 3/8" DR, 6 PT, DEEP, 1/2"	1	F	10	30
SOCKET, SOCKET WRENCH, 3/8" DR, 6 PT, DEEP, 1/4"	1	F	8	34
SOCKET, SOCKET WRENCH, 3/8" DR, 6 PT, DEEP, 1/4"	1	F	10	34
SOCKET, SOCKET WRENCH, 3/8" DR, 6 PT, DEEP, 10MM	1	F	8	20
SOCKET, SOCKET WRENCH, 3/8" DR, 6 PT, DEEP, 10MM	1	F	10	20
SOCKET, SOCKET WRENCH, 3/8" DR, 6 PT, DEEP, 11/16"	1	F	8	27
SOCKET, SOCKET WRENCH, 3/8" DR, 6 PT, DEEP, 11/16"	1	F	10	27
SOCKET, SOCKET WRENCH, 3/8" DR, 6 PT, DEEP, 11MM	1	F	8	19
SOCKET, SOCKET WRENCH, 3/8" DR, 6 PT, DEEP, 11MM	1	F	10	19
SOCKET, SOCKET WRENCH, 3/8" DR, 6 PT, DEEP, 12MM	1	F	8	18
SOCKET, SOCKET WRENCH, 3/8" DR, 6 PT, DEEP, 12MM	1	F	10	18
SOCKET, SOCKET WRENCH, 3/8" DR, 6 PT, DEEP, 13/16"	1	F	8	25
SOCKET, SOCKET WRENCH, 3/8" DR, 6 PT, DEEP, 13/16"	1	F	10	25
SOCKET, SOCKET WRENCH, 3/8" DR, 6 PT, DEEP, 13MM	1	F	8	17
SOCKET, SOCKET WRENCH, 3/8" DR, 6 PT, DEEP, 13MM	1	F	10	17
SOCKET, SOCKET WRENCH, 3/8" DR, 6 PT, DEEP, 14MM	1	F	8	16
SOCKET, SOCKET WRENCH, 3/8" DR, 6 PT, DEEP, 14MM	1	F	10	16
SOCKET, SOCKET WRENCH, 3/8" DR, 6 PT, DEEP, 15/16"	1	F	8	23
SOCKET, SOCKET WRENCH, 3/8" DR, 6 PT, DEEP, 15/16"	1	F	10	23
SOCKET, SOCKET WRENCH, 3/8" DR, 6 PT, DEEP, 15MM	1	F	8	15
SOCKET, SOCKET WRENCH, 3/8" DR, 6 PT, DEEP, 15MM	1	F	10	15
SOCKET, SOCKET WRENCH, 3/8" DR, 6 PT, DEEP, 16MM	1	F	8	14
SOCKET, SOCKET WRENCH, 3/8" DR, 6 PT, DEEP, 16MM	1	F	10	14
SOCKET, SOCKET WRENCH, 3/8" DR, 6 PT, DEEP, 17MM	1	F	8	13
SOCKET, SOCKET WRENCH, 3/8" DR, 6 PT, DEEP, 17MM	1	F	10	13
SOCKET, SOCKET WRENCH, 3/8" DR, 6 PT, DEEP, 18MM	1	F	8	12
SOCKET, SOCKET WRENCH, 3/8" DR, 6 PT, DEEP, 18MM	1	F	10	12
SOCKET, SOCKET WRENCH, 3/8" DR, 6 PT, DEEP, 19MM	1	F	8	11
SOCKET, SOCKET WRENCH, 3/8" DR, 6 PT, DEEP, 19MM	1	F	10	11

TM 9-4910-783-13&P

SATS FIELD MAINTENANCE MODULE #1 (FMM1) COMPONENT LIST

0059 00

NOMENCLATURE	QTY	RACK	DRAWER	LOCATION
SOCKET, SOCKET WRENCH, 3/8" DR, 6 PT, DEEP, 20MM	1	F	8	10
SOCKET, SOCKET WRENCH, 3/8" DR, 6 PT, DEEP, 20MM	1	F	10	10
SOCKET, SOCKET WRENCH, 3/8" DR, 6 PT, DEEP, 21MM	1	F	8	9
SOCKET, SOCKET WRENCH, 3/8" DR, 6 PT, DEEP, 21MM	1	F	10	9
SOCKET, SOCKET WRENCH, 3/8" DR, 6 PT, DEEP, 22MM	1	F	8	8
SOCKET, SOCKET WRENCH, 3/8" DR, 6 PT, DEEP, 22MM	1	F	10	8
SOCKET, SOCKET WRENCH, 3/8" DR, 6 PT, DEEP, 23MM	1	F	8	7
SOCKET, SOCKET WRENCH, 3/8" DR, 6 PT, DEEP, 23MM	1	F	10	7
SOCKET, SOCKET WRENCH, 3/8" DR, 6 PT, DEEP, 26MM	1	F	8	6
SOCKET, SOCKET WRENCH, 3/8" DR, 6 PT, DEEP, 26MM	1	F	10	6
SOCKET, SOCKET WRENCH, 3/8" DR, 6 PT, DEEP, 3/4"	1	F	8	26
SOCKET, SOCKET WRENCH, 3/8" DR, 6 PT, DEEP, 3/4"	1	F	10	26
SOCKET, SOCKET WRENCH, 3/8" DR, 6 PT, DEEP, 3/8"	1	F	8	32
SOCKET, SOCKET WRENCH, 3/8" DR, 6 PT, DEEP, 3/8"	1	F	10	32
SOCKET, SOCKET WRENCH, 3/8" DR, 6 PT, DEEP, 5/16"	1	F	8	33
SOCKET, SOCKET WRENCH, 3/8" DR, 6 PT, DEEP, 5/16"	1	F	10	33
SOCKET, SOCKET WRENCH, 3/8" DR, 6 PT, DEEP, 5/8"	1	F	8	28
SOCKET, SOCKET WRENCH, 3/8" DR, 6 PT, DEEP, 5/8"	1	F	10	28
SOCKET, SOCKET WRENCH, 3/8" DR, 6 PT, DEEP, 6MM	1	F	8	35
SOCKET, SOCKET WRENCH, 3/8" DR, 6 PT, DEEP, 6MM	1	F	10	35
SOCKET, SOCKET WRENCH, 3/8" DR, 6 PT, DEEP, 7/16"	1	F	8	31
SOCKET, SOCKET WRENCH, 3/8" DR, 6 PT, DEEP, 7/16"	1	F	10	31
SOCKET, SOCKET WRENCH, 3/8" DR, 6 PT, DEEP, 7/8"	1	F	8	24
SOCKET, SOCKET WRENCH, 3/8" DR, 6 PT, DEEP, 7/8"	1	F	10	24
SOCKET, SOCKET WRENCH, 3/8" DR, 6 PT, DEEP, 7MM	1	F	8	36
SOCKET, SOCKET WRENCH, 3/8" DR, 6 PT, DEEP, 7MM	1	F	10	36
SOCKET, SOCKET WRENCH, 3/8" DR, 6 PT, DEEP, 8MM	1	F	8	37
SOCKET, SOCKET WRENCH, 3/8" DR, 6 PT, DEEP, 8MM	1	F	10	37
SOCKET, SOCKET WRENCH, 3/8" DR, 6 PT, DEEP, 9/16"	1	F	8	29
SOCKET, SOCKET WRENCH, 3/8" DR, 6 PT, DEEP, 9/16"	1	F	10	29
SOCKET, SOCKET WRENCH, 3/8" DR, 6 PT, DEEP, 9MM	1	F	8	21
SOCKET, SOCKET WRENCH, 3/8" DR, 6 PT, DEEP, 9MM	1	F	10	21
SOCKET, SOCKET WRENCH, 3/8" DR, 6 PT, REGULAR, 1"	1	F	8	57
SOCKET, SOCKET WRENCH, 3/8" DR, 6 PT, REGULAR, 1"	1	F	10	57
SOCKET, SOCKET WRENCH, 3/8" DR, 6 PT, REGULAR, 1/2"	1	F	8	65
SOCKET, SOCKET WRENCH, 3/8" DR, 6 PT, REGULAR, 1/2"	1	F	10	65
SOCKET, SOCKET WRENCH, 3/8" DR, 6 PT, REGULAR, 1/4"	1	F	8	69

TM 9-4910-783-13&P

SATS FIELD MAINTENANCE MODULE #1 (FMM1) COMPONENT LIST

0059 00

NOMENCLATURE	QTY	RACK	DRAWER	LOCATION
SOCKET, SOCKET WRENCH, 3/8"DR, 6PT, REGULAR, 1/4"	1	F	10	69
SOCKET, SOCKET WRENCH, 3/8"DR, 6PT, REGULAR, 10MM	1	F	8	42
SOCKET, SOCKET WRENCH, 3/8"DR, 6PT, REGULAR, 10MM	1	F	10	42
SOCKET, SOCKET WRENCH, 3/8"DR, 6PT, REGULAR, 11/16"	1	F	8	62
SOCKET, SOCKET WRENCH, 3/8"DR, 6PT, REGULAR, 11/16"	1	F	10	62
SOCKET, SOCKET WRENCH, 3/8"DR, 6PT, REGULAR, 11MM	1	F	8	43
SOCKET, SOCKET WRENCH, 3/8"DR, 6PT, REGULAR, 11MM	1	F	10	43
SOCKET, SOCKET WRENCH, 3/8"DR, 6PT, REGULAR, 12MM	1	F	8	44
SOCKET, SOCKET WRENCH, 3/8"DR, 6PT, REGULAR, 12MM	1	F	10	44
SOCKET, SOCKET WRENCH, 3/8"DR, 6PT, REGULAR, 13/16"	1	F	8	60
SOCKET, SOCKET WRENCH, 3/8"DR, 6PT, REGULAR, 13/16"	1	F	10	60
SOCKET, SOCKET WRENCH, 3/8"DR, 6PT, REGULAR, 13MM	1	F	8	45
SOCKET, SOCKET WRENCH, 3/8"DR, 6PT, REGULAR, 13MM	1	F	10	45
SOCKET, SOCKET WRENCH, 3/8"DR, 6PT, REGULAR, 14MM	1	F	8	46
SOCKET, SOCKET WRENCH, 3/8"DR, 6PT, REGULAR, 14MM	1	F	10	46
SOCKET, SOCKET WRENCH, 3/8"DR, 6PT, REGULAR, 15/16"	1	F	8	58
SOCKET, SOCKET WRENCH, 3/8"DR, 6PT, REGULAR, 15/16"	1	F	10	58
SOCKET, SOCKET WRENCH, 3/8"DR, 6PT, REGULAR, 15MM	1	F	8	47
SOCKET, SOCKET WRENCH, 3/8"DR, 6PT, REGULAR, 15MM	1	F	10	47
SOCKET, SOCKET WRENCH, 3/8"DR, 6PT, REGULAR, 16MM	1	F	8	48
SOCKET, SOCKET WRENCH, 3/8"DR, 6PT, REGULAR, 16MM	1	F	10	48
SOCKET, SOCKET WRENCH, 3/8"DR, 6PT, REGULAR, 17MM	1	F	8	49
SOCKET, SOCKET WRENCH, 3/8"DR, 6PT, REGULAR, 17MM	1	F	10	49
SOCKET, SOCKET WRENCH, 3/8"DR, 6PT, REGULAR, 18MM	1	F	8	50
SOCKET, SOCKET WRENCH, 3/8"DR, 6PT, REGULAR, 18MM	1	F	10	50
SOCKET, SOCKET WRENCH, 3/8"DR, 6PT, REGULAR, 19MM	1	F	8	51
SOCKET, SOCKET WRENCH, 3/8"DR, 6PT, REGULAR, 19MM	1	F	10	51
SOCKET, SOCKET WRENCH, 3/8"DR, 6PT, REGULAR, 20MM	1	F	8	52
SOCKET, SOCKET WRENCH, 3/8"DR, 6PT, REGULAR, 20MM	1	F	10	52
SOCKET, SOCKET WRENCH, 3/8"DR, 6PT, REGULAR, 21MM	1	F	8	53
SOCKET, SOCKET WRENCH, 3/8"DR, 6PT, REGULAR, 21MM	1	F	10	53
SOCKET, SOCKET WRENCH, 3/8"DR, 6PT, REGULAR, 22MM	1	F	8	54
SOCKET, SOCKET WRENCH, 3/8"DR, 6PT, REGULAR, 22MM	1	F	10	54
SOCKET, SOCKET WRENCH, 3/8"DR, 6PT, REGULAR, 23MM	1	F	8	55
SOCKET, SOCKET WRENCH, 3/8"DR, 6PT, REGULAR, 23MM	1	F	10	55
SOCKET, SOCKET WRENCH, 3/8"DR, 6PT, REGULAR, 26MM	1	F	8	56
SOCKET, SOCKET WRENCH, 3/8"DR, 6PT, REGULAR, 26MM	1	F	10	56

TM 9-4910-783-13&P

SATS FIELD MAINTENANCE MODULE #1 (FMM1) COMPONENT LIST

0059 00

NOMENCLATURE	QTY	RACK	DRAWER	LOCATION
SOCKET, SOCKET WRENCH, 3/8" DR, 6 PT, REGULAR, 3/4"	1	F	8	61
SOCKET, SOCKET WRENCH, 3/8" DR, 6 PT, REGULAR, 3/4"	1	F	10	61
SOCKET, SOCKET WRENCH, 3/8" DR, 6 PT, REGULAR, 3/8"	1	F	8	67
SOCKET, SOCKET WRENCH, 3/8" DR, 6 PT, REGULAR, 3/8"	1	F	10	67
SOCKET, SOCKET WRENCH, 3/8" DR, 6 PT, REGULAR, 5/16"	1	F	8	68
SOCKET, SOCKET WRENCH, 3/8" DR, 6 PT, REGULAR, 5/16"	1	F	10	68
SOCKET, SOCKET WRENCH, 3/8" DR, 6 PT, REGULAR, 5/8"	1	F	8	63
SOCKET, SOCKET WRENCH, 3/8" DR, 6 PT, REGULAR, 5/8"	1	F	10	63
SOCKET, SOCKET WRENCH, 3/8" DR, 6 PT, REGULAR, 6MM	1	F	8	38
SOCKET, SOCKET WRENCH, 3/8" DR, 6 PT, REGULAR, 6MM	1	F	10	38
SOCKET, SOCKET WRENCH, 3/8" DR, 6 PT, REGULAR, 7/16"	1	F	8	66
SOCKET, SOCKET WRENCH, 3/8" DR, 6 PT, REGULAR, 7/16"	1	F	10	66
SOCKET, SOCKET WRENCH, 3/8" DR, 6 PT, REGULAR, 7/8"	1	F	8	59
SOCKET, SOCKET WRENCH, 3/8" DR, 6 PT, REGULAR, 7/8"	1	F	10	59
SOCKET, SOCKET WRENCH, 3/8" DR, 6 PT, REGULAR, 7MM	1	F	8	39
SOCKET, SOCKET WRENCH, 3/8" DR, 6 PT, REGULAR, 7MM	1	F	10	39
SOCKET, SOCKET WRENCH, 3/8" DR, 6 PT, REGULAR, 8MM	1	F	8	40
SOCKET, SOCKET WRENCH, 3/8" DR, 6 PT, REGULAR, 8MM	1	F	10	40
SOCKET, SOCKET WRENCH, 3/8" DR, 6 PT, REGULAR, 9/16"	1	F	8	64
SOCKET, SOCKET WRENCH, 3/8" DR, 6 PT, REGULAR, 9/16"	1	F	10	64
SOCKET, SOCKET WRENCH, 3/8" DR, 6 PT, REGULAR, 9MM	1	F	8	41
SOCKET, SOCKET WRENCH, 3/8" DR, 6 PT, REGULAR, 9MM	1	F	10	41
STEERING WHEEL PULLER	1	E	7	11
STEP PLATE ADAPTER, 1-1/8"	1	E	7	22
STEP PLATE ADAPTER, 1-1/4"	1	E	7	24
STEP PLATE ADAPTER, 1-3/4"	1	E	7	16
STEP PLATE ADAPTER, 1-3/8"	1	E	7	26
STEP PLATE ADAPTER, 1-5/8"	1	E	7	20
STEP PLATE ADAPTER, 1-7/8"	1	E	7	12
STEP PLATE ADAPTER, 1"	1	E	7	19
STEP PLATE ADAPTER, 2-1/2"	1	E	7	9
STEP PLATE ADAPTER, 2-1/8"	1	E	7	13
STEP PLATE ADAPTER, 2-3/8"	1	E	7	10
STEP PLATE ADAPTER, 2"	1	E	7	15
STUD REMOVER, 5/16" - 3/4" CAPACITY	1	F	8	78
STUD REMOVER, 5/16" - 3/4" CAPACITY	1	F	10	78
TOOL KIT, HOSE END CRIMPING	1	G	3	1

TM 9-4910-783-13&P

SATS FIELD MAINTENANCE MODULE #1 (FMM1) COMPONENT LIST

0059 00

NOMENCLATURE	QTY	RACK	DRAWER	LOCATION
TOOL KIT, HOSE END CRIMPING	1	G	6	4
TORQUE WRENCH MULTIPLIER	1	P		4
TRESTLE, HOIST, PORTABLE (NOTE: GFE ITEM)	2	Q		3
UNIVERSAL, 3/8"	1	F	8	72
UNIVERSAL, 3/8"	1	F	10	72
WISE, PIPE	1	G	6	2
WHEEL, ABRASIVE, 36 GRIT (PROTYPE ONLY)	1	G	3	6
WHEEL, ABRASIVE, 90 GRIT (PROTYPE ONLY)	1	G	3	5
WRENCH KIT, RATCHET, PNEUMATIC	1	G	7	1
WRENCH, ADJUSTABLE, 10"	1	G	6	5
WRENCH, ADJUSTABLE, 10"	1	G	6	7
WRENCH, ADJUSTABLE, 18"	1	G	3	2
WRENCH, ADJUSTABLE, 18"	1	G	3	3
WRENCH, COMBINATION, 1/2"	1	F	1	20
WRENCH, COMBINATION, 1/2"	1	F	3	20
WRENCH, COMBINATION, 11/16"	1	F	1	13
WRENCH, COMBINATION, 11/16"	1	F	3	13
WRENCH, COMBINATION, 1"	1	F	1	8
WRENCH, COMBINATION, 1"	1	F	3	8
WRENCH, COMBINATION, 1"	1	F	5	8
WRENCH, COMBINATION, 1/2"	1	F	5	20
WRENCH, COMBINATION, 1/4"	1	F	1	16
WRENCH, COMBINATION, 1/4"	1	F	3	16
WRENCH, COMBINATION, 1/4"	1	F	5	16
WRENCH, COMBINATION, 10MM	1	F	7	1
WRENCH, COMBINATION, 11/16"	1	F	5	13
WRENCH, COMBINATION, 1-1/16"	1	F	1	7
WRENCH, COMBINATION, 1-1/16"	1	F	3	7
WRENCH, COMBINATION, 1-1/16"	1	F	5	7
WRENCH, COMBINATION, 1-1/2"	1	F	1	1
WRENCH, COMBINATION, 1-1/2"	1	F	3	1
WRENCH, COMBINATION, 1-1/2"	1	F	5	1
WRENCH, COMBINATION, 1-1/4"	1	F	1	5
WRENCH, COMBINATION, 1-1/4"	1	F	3	5
WRENCH, COMBINATION, 1-1/4"	1	F	5	5
WRENCH, COMBINATION, 1-1/8"	1	F	1	6
WRENCH, COMBINATION, 1-1/8"	1	F	3	6

TM 9-4910-783-13&P

SATS FIELD MAINTENANCE MODULE #1 (FMM1) COMPONENT LIST

0059 00

NOMENCLATURE	QTY	RACK	DRAWER	LOCATION
WRENCH, COMBINATION, 1-1/8"	1	F	5	6
WRENCH, COMBINATION, 1-11/16"	1	F	2	5
WRENCH, COMBINATION, 1-11/16"	1	F	4	5
WRENCH, COMBINATION, 1-11/16"	1	F	6	5
WRENCH, COMBINATION, 1-13/16"	1	F	2	3
WRENCH, COMBINATION, 1-13/16"	1	F	4	3
WRENCH, COMBINATION, 11MM	1	F	7	2
WRENCH, COMBINATION, 12MM	1	F	7	3
WRENCH, COMBINATION, 13/16"	1	F	1	11
WRENCH, COMBINATION, 13/16"	1	F	3	11
WRENCH, COMBINATION, 13/16"	1	F	5	11
WRENCH, COMBINATION, 1-3/4"	1	F	2	4
WRENCH, COMBINATION, 1-3/4"	1	F	4	4
WRENCH, COMBINATION, 1-3/4"	1	F	6	4
WRENCH, COMBINATION, 1-3/8"	1	F	1	3
WRENCH, COMBINATION, 1-3/8"	1	F	3	3
WRENCH, COMBINATION, 1-3/8"	1	F	5	3
WRENCH, COMBINATION, 13MM	1	F	7	4
WRENCH, COMBINATION, 14MM	1	F	7	5
WRENCH, COMBINATION, 1-5/16"	1	F	1	4
WRENCH, COMBINATION, 1-5/16"	1	F	3	4
WRENCH, COMBINATION, 1-5/16"	1	F	5	4
WRENCH, COMBINATION, 15/16"	1	F	1	9
WRENCH, COMBINATION, 15/16"	1	F	3	9
WRENCH, COMBINATION, 15/16"	1	F	5	9
WRENCH, COMBINATION, 1-5/8"	1	F	2	6
WRENCH, COMBINATION, 1-5/8"	1	F	4	6
WRENCH, COMBINATION, 1-5/8"	1	F	6	6
WRENCH, COMBINATION, 15MM	1	F	7	6
WRENCH, COMBINATION, 16MM	1	F	7	7
WRENCH, COMBINATION, 1-7/16"	1	F	1	2
WRENCH, COMBINATION, 1-7/16"	1	F	3	2
WRENCH, COMBINATION, 1-7/16"	1	F	5	2
WRENCH, COMBINATION, 1-7/8"	1	F	2	2
WRENCH, COMBINATION, 1-7/8"	1	F	4	2
WRENCH, COMBINATION, 1-7/8"	1	F	6	2
WRENCH, COMBINATION, 17MM	1	F	7	8
WRENCH, COMBINATION, 18MM	1	F	7	9

TM 9-4910-783-13&P

SATS FIELD MAINTENANCE MODULE #1 (FMM1) COMPONENT LIST

0059 00

NOMENCLATURE	QTY	RACK	DRAWER	LOCATION
WRENCH, COMBINATION, 1-9/16"	1	F	6	3
WRENCH, COMBINATION, 19MM	1	F	7	10
WRENCH, COMBINATION, 2"	1	F	2	1
WRENCH, COMBINATION, 2"	1	F	4	1
WRENCH, COMBINATION, 2"	1	F	6	1
WRENCH, COMBINATION, 20MM	1	F	7	11
WRENCH, COMBINATION, 21MM	1	F	7	12
WRENCH, COMBINATION, 22MM	1	F	7	13
WRENCH, COMBINATION, 23MM	1	F	7	14
WRENCH, COMBINATION, 24MM	1	F	7	15
WRENCH, COMBINATION, 25MM	1	F	7	16
WRENCH, COMBINATION, 26MM	1	F	7	17
WRENCH, COMBINATION, 27MM	1	F	7	18
WRENCH, COMBINATION, 28MM	1	F	7	19
WRENCH, COMBINATION, 29MM	1	F	7	20
WRENCH, COMBINATION, 3/4"	1	F	1	12
WRENCH, COMBINATION, 3/4"	1	F	3	12
WRENCH, COMBINATION, 3/4"	1	F	5	12
WRENCH, COMBINATION, 3/8"	1	F	1	18
WRENCH, COMBINATION, 3/8"	1	F	3	18
WRENCH, COMBINATION, 3/8"	1	F	5	18
WRENCH, COMBINATION, 30MM	1	F	7	21
WRENCH, COMBINATION, 32MM	1	F	7	22
WRENCH, COMBINATION, 36MM	1	F	7	23
WRENCH, COMBINATION, 5/16"	1	F	1	17
WRENCH, COMBINATION, 5/16"	1	F	3	17
WRENCH, COMBINATION, 5/16"	1	F	5	17
WRENCH, COMBINATION, 5/8"	1	F	1	14
WRENCH, COMBINATION, 5/8"	1	F	3	14
WRENCH, COMBINATION, 5/8"	1	F	5	14
WRENCH, COMBINATION, 7/16"	1	F	1	19
WRENCH, COMBINATION, 7/16"	1	F	3	19
WRENCH, COMBINATION, 7/16"	1	F	5	19
WRENCH, COMBINATION, 7/8"	1	F	1	10
WRENCH, COMBINATION, 7/8"	1	F	3	10
WRENCH, COMBINATION, 7/8"	1	F	5	10
WRENCH, COMBINATION, 7MM	1	F	7	24
WRENCH, COMBINATION, 8MM	1	F	7	25

TM 9-4910-783-13&P

SATS FIELD MAINTENANCE MODULE #1 (FMM1) COMPONENT LIST

0059 00

NOMENCLATURE	QTY	RACK	DRAWER	LOCATION
WRENCH, COMBINATION, 9/16"	1	F	1	15
WRENCH, COMBINATION, 9/16"	1	F	3	15
WRENCH, COMBINATION, 9/16"	1	F	5	15
WRENCH, COMBINATION, 9MM	1	F	7	26
WRENCH, ELECTRIC IMPACT, 1/2" SQ DR,	1	E	4	82
WRENCH, PIPE, 36"	2	B	1	1
WRENCH, PNEUMATIC IMPACT, 1/2" SQ DR	1	E	4	92
WRENCH, TORQUE, CLICK, RATCHETING, 3/4" DRIVE, 600 FT-LB	2	P		8
WRENCH, TORQUE, DIAL, 1/4", 30 IN-LB	1	E	5	3
WRENCH, TORQUE, DIAL, 3/8", 300 IN-LB	1	E	5	2

TM 9-4910-783-13&P

SATS FMM1 TOOL INVENTORY LIST

0059 00

				INVENTORY	
NOMENCLATURE	QTY	RACK	DRAWER	LOCATION	AMOUNT
LIFT, TRANSMISSION AND DIFFERENTIAL	1	A		3a	

A – Floor Positions

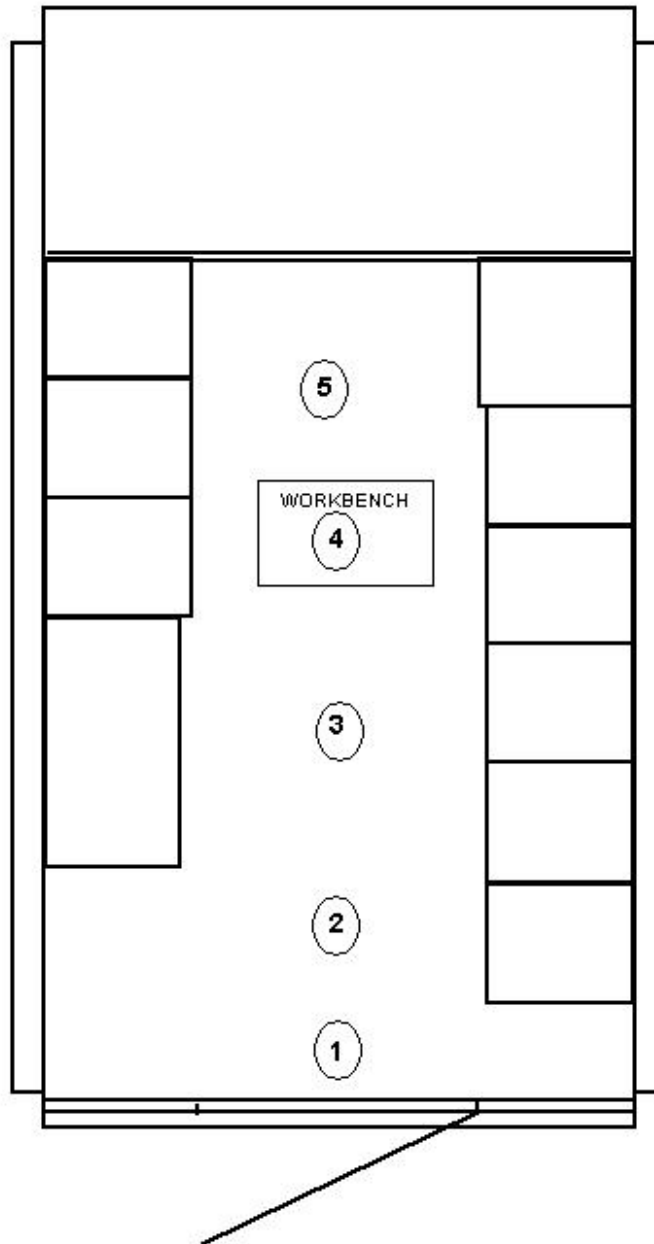

TM 9-4910-783-13&P

SATS FMM1 TOOL INVENTORY LIST

0059 00

INVENTORY

NOMENCLATURE	QTY	RACK	SHELF	LOCATION	AMOUNT
WRENCH, PIPE, 36"	2	B	1	B1	
GRINDING MACHINE, UTILITY	1	B	3	B2	
JACK, BOTTLE, HYDRAULIC, HAND, 30 TON	1	B	3	B3	
SLING, ENGINE AND TRANSMISSION, 2 TON	2	B	4	B1	
JACK KIT, HYDRAULIC, HAND	1	B	4	B2	

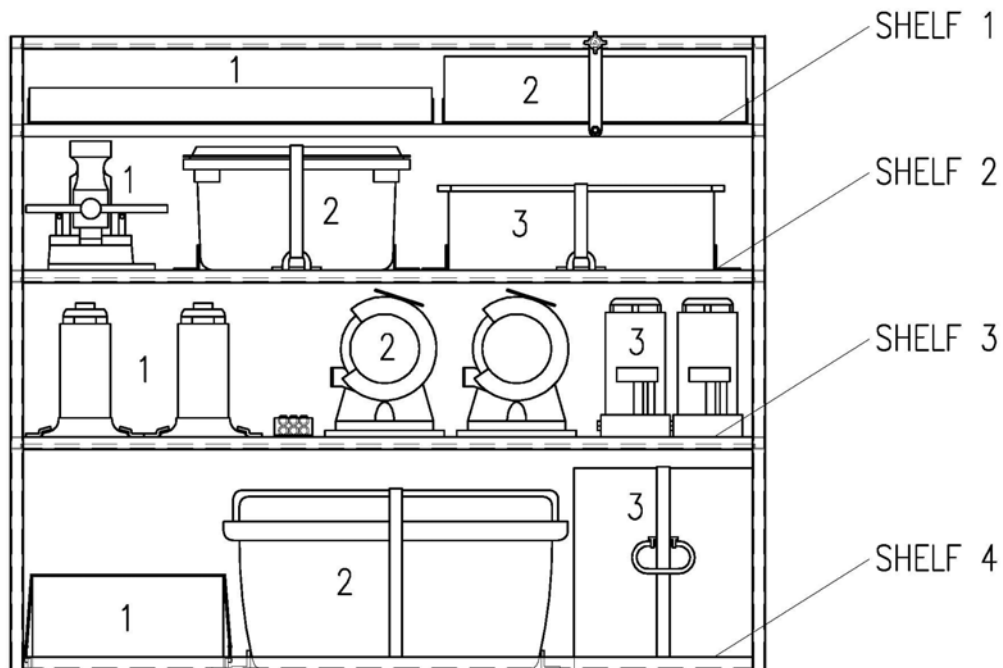

FRONT VIEW OF B

TM 9-4910-783-13&P

E, 1

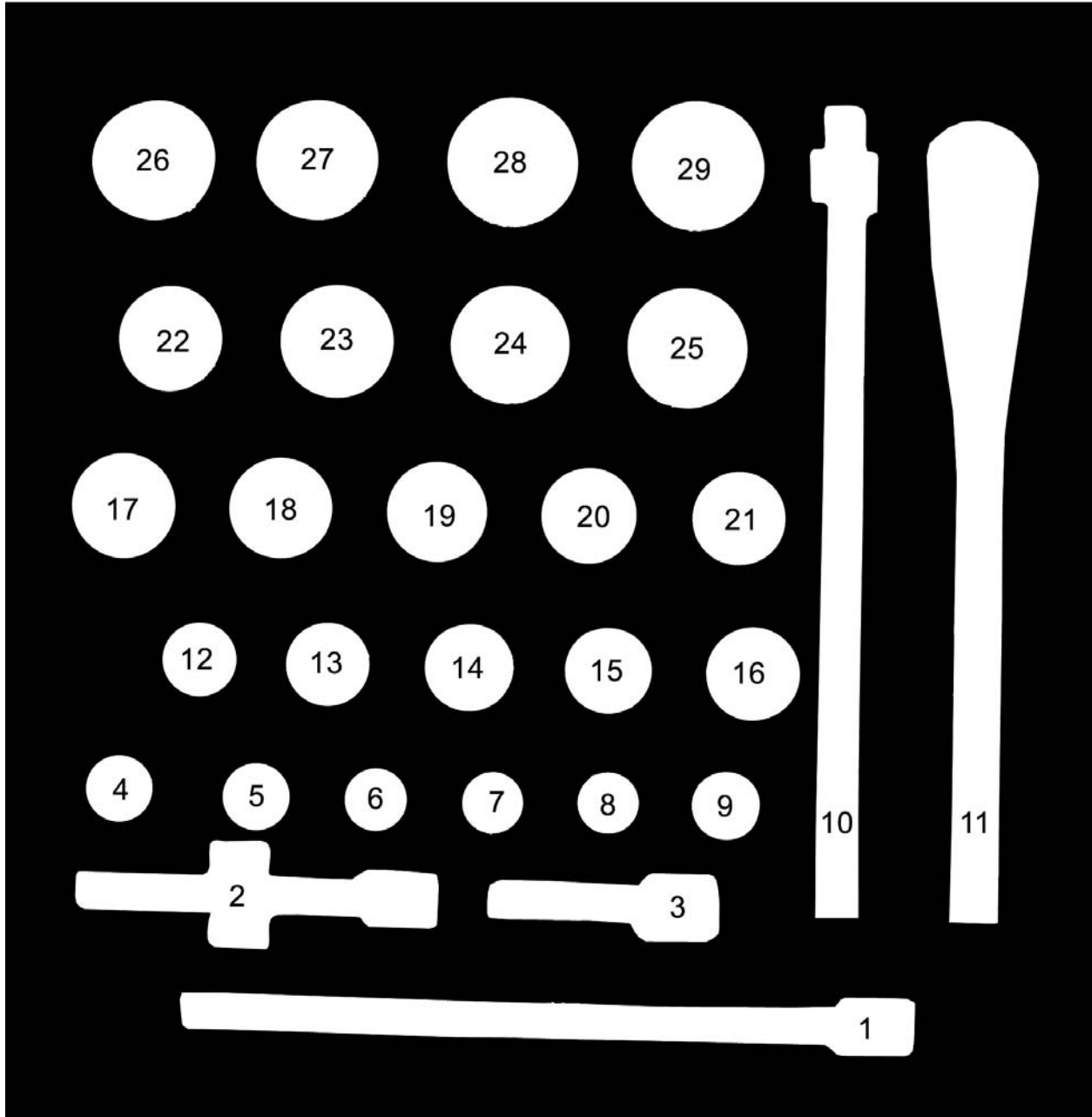

TM 9-4910-783-13&P

SATS FMM1 TOOL INVENTORY LIST

0059 00

NOMENCLATURE	QTY	RACK	DRAWER	LOCATION	AMOUNT
EXTENSION, 3/4" DR, 15" LONG	1	E	1	1	
EXTENSION, 3/4" DR, 7.5" LONG	1	E	1	2	
EXTENSION, 3/4" DR, 4.5" LONG	1	E	1	3	
SOCKET, SOCKET WRENCH, 3/4" DR, 12 PT, 1-1/16"	1	E	1	4	
SOCKET, SOCKET WRENCH, 3/4" DR, 12 PT, 1"	1	E	1	5	
SOCKET, SOCKET WRENCH, 3/4" DR, 12 PT, 15/16"	1	E	1	6	
SOCKET, SOCKET WRENCH, 3/4" DR, 12 PT, 7/8"	1	E	1	7	
ADAPTER, 3/4" DR TO 1/2" DR, 1/2"	1	E	1	8	
JOINT, UNIVERSAL, 3/4" DR	1	E	1	9	
HANDLE, SLIDING-T, 3/4" DR, 17" LONG	1	E	1	10	
HANDLE, RATCHET, 3/4" DR, 17" LONG	1	E	1	11	
SOCKET, SOCKET WRENCH, 3/4" DR, 12 PT, 1-1/8"	1	E	1	12	
SOCKET, SOCKET WRENCH, 3/4" DR, 12 PT, 1-1/4"	1	E	1	13	
SOCKET, SOCKET WRENCH, 3/4" DR, 12 PT, 1-5/16"	1	E	1	14	
SOCKET, SOCKET WRENCH, 3/4" DR, 12 PT, 1-3/8"	1	E	1	15	
SOCKET, SOCKET WRENCH, 3/4" DR, 12 PT, 1-7/16"	1	E	1	16	
SOCKET, SOCKET WRENCH, 3/4" DR, 12 PT, 1-3/4"	1	E	1	17	
SOCKET, SOCKET WRENCH, 3/4" DR, 12 PT, 1-11/16"	1	E	1	18	
SOCKET, SOCKET WRENCH, 3/4" DR, 12 PT, 1-5/8"	1	E	1	19	
SOCKET, SOCKET WRENCH, 3/4" DR, 12 PT, 1-9/16"	1	E	1	20	
SOCKET, SOCKET WRENCH, 3/4" DR, 12 PT, 1-1/2"	1	E	1	21	
SOCKET, SOCKET WRENCH, 3/4" DR, 12 PT, 1-13/16"	1	E	1	22	
SOCKET, SOCKET WRENCH, 3/4" DR, 12 PT, 1-7/8"	1	E	1	23	
SOCKET, SOCKET WRENCH, 3/4" DR, 12 PT, 2"	1	E	1	24	
SOCKET, SOCKET WRENCH, 3/4" DR, 12 PT, 2-1/16"	1	E	1	25	
SOCKET, SOCKET WRENCH, 3/4" DR, 12 PT, 2-1/8"	1	E	1	26	
SOCKET, SOCKET WRENCH, 3/4" DR, 12 PT, 2-3/16"	1	E	1	27	
SOCKET, SOCKET WRENCH, 3/4" DR, 12 PT, 2-1/4"	1	E	1	28	
SOCKET, SOCKET WRENCH, 3/4" DR, 12 PT, 2-3/8"	1	E	1	29	

TM 9-4910-783-13&P

SATS FMM1 TOOL INVENTORY LIST

0059 00

INVENTORY

NOMENCLATURE	QTY	RACK	DRAWER	LOCATION	AMOUNT
SLIDING DRIVE PLUG, 1" DR, 2-1/72"	1	E	2	1	
EXTENSION, 1" DR, 8" LONG	1	E	2	2	
EXTENSION, 1" DR, 17" LONG	1	E	2	3	
RATCHET, REVERSIBLE, 1" DR	1	E	2	4	
HANDLE, TEE SLIDING, 1" DR, 28" LONG	1	E	2	5	
SCREWDRIVER ATTACHMENT, TORX BIT, 3/8" DR, T-50	1	E	2	10	
SCREWDRIVER ATTACHMENT, TORX BIT, 3/8" DR, T-55	1	E	2	11	
SCREWDRIVER ATTACHMENT, TORX BIT, 1/4" DR, T-8	1	E	2	12	
SCREWDRIVER ATTACHMENT, TORX BIT, 1/4" DR, T-10	1	E	2	13	
SCREWDRIVER ATTACHMENT, TORX BIT, 1/4" DR, T-15	1	E	2	14	
SCREWDRIVER ATTACHMENT, TORX BIT, 1/4" DR, T-20	1	E	2	15	
SCREWDRIVER ATTACHMENT, TORX BIT, 1/4" DR, T-25	1	E	2	16	
SCREWDRIVER ATTACHMENT, TORX BIT, 1/4" DR, T-27	1	E	2	17	
SCREWDRIVER ATTACHMENT, TORX BIT, T-30	1	E	2	6	
SCREWDRIVER ATTACHMENT, TORX BIT, 3/8" DR, T-40	1	E	2	7	
SCREWDRIVER ATTACHMENT, TORX BIT, 3/8" DR, T-45	1	E	2	8	
SCREWDRIVER ATTACHMENT, TORX BIT, 3/8" DR, T-47	1	E	2	9	

E, 2

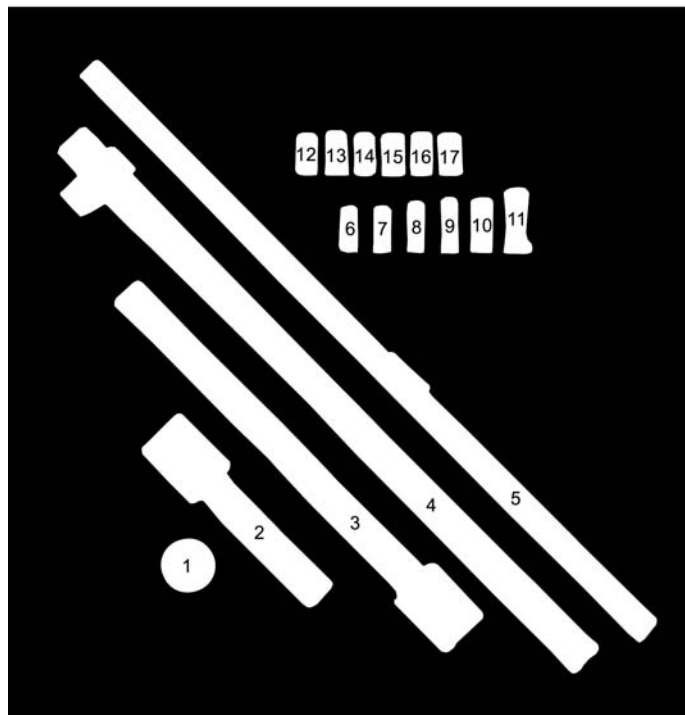

TM 9-4910-783-13&P

SATS FMM1 TOOL INVENTORY LIST

0059 00

THIS PAGE INTENTIONALLY LEFT BLANK

TM 9-4910-783-13&P

E 3

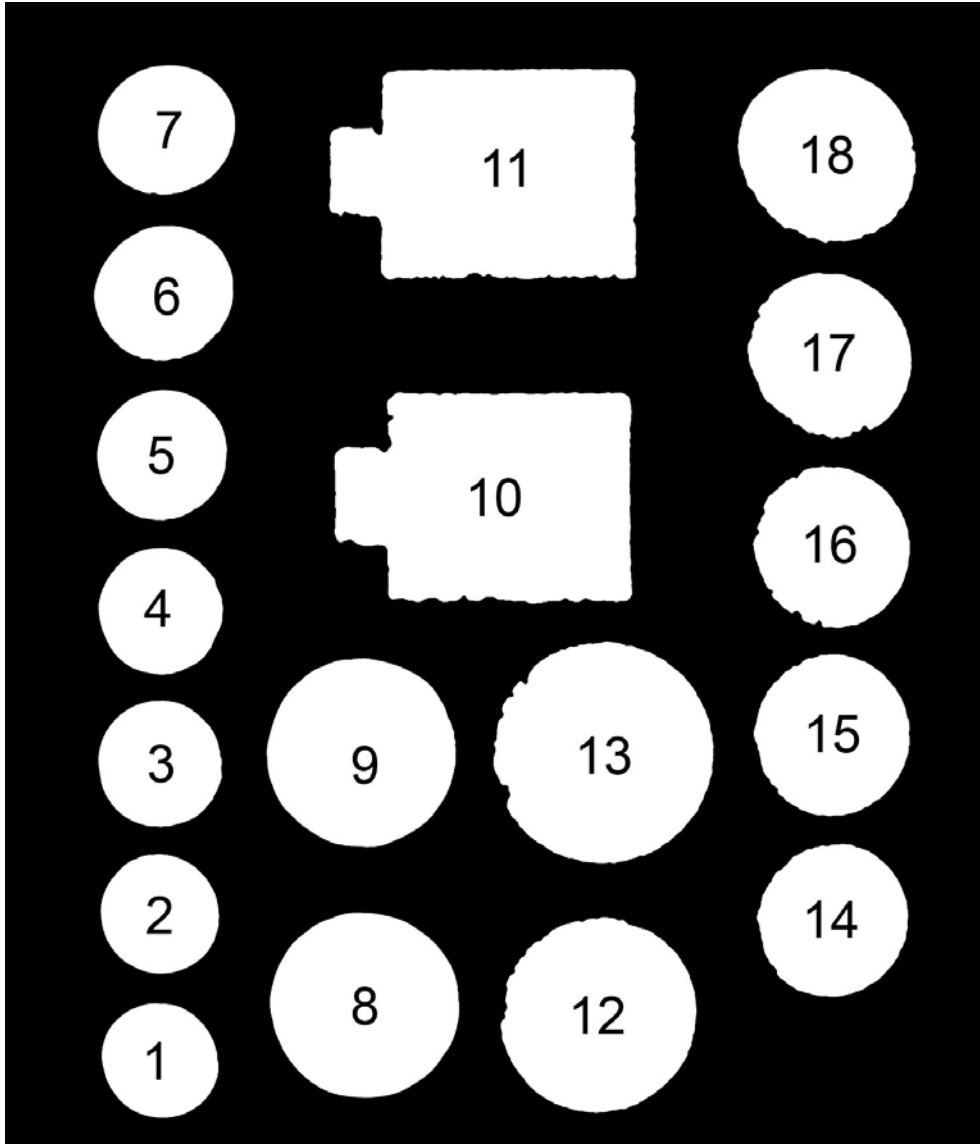

TM 9-4910-783-13&P

SATS FMM1 TOOL INVENTORY LIST

0059 00

					INVENTORY
NOMENCLATURE	QTY	RACK	DRAWER	LOCATION	AMOUNT
SOCKET, SOCKET WRENCH, 1" DR, 1-7/16"	1	E	3	1	
SOCKET, SOCKET WRENCH, 1" DR, 1-1/2 "	1	E	3	2	
SOCKET, SOCKET WRENCH, 1" DR, 1-5/8"	1	E	3	3	
SOCKET, SOCKET WRENCH, 1" DR, 1-11/16"	1	E	3	4	
SOCKET, SOCKET WRENCH, 1" DR, 1-13/16"	1	E	3	5	
SOCKET, SOCKET WRENCH, 1" DR, 1-7/8"	1	E	3	6	
SOCKET, SOCKET WRENCH, 1" DR, 2"	1	E	3	7	
SOCKET, SOCKET WRENCH, 1" DR, 2-5/8"	1	E	3	8	
SOCKET, SOCKET WRENCH, 1" DR, 2-3/4"	1	E	3	9	
SOCKET, SOCKET WRENCH, 1" DR, 3"	1	E	3	10	
SOCKET, SOCKET WRENCH, 1" DR, 3-1/8"	1	E	3	11	
SOCKET, SOCKET WRENCH, 1" DR, 2-9/16"	1	E	3	12	
SOCKET, SOCKET WRENCH, 1" DR, 2-13/16"	1	E	3	13	
SOCKET, SOCKET WRENCH, 1" DR, 2-1/8"	1	E	3	14	
SOCKET, SOCKET WRENCH, 1" DR, 2-3/16"	1	E	3	15	
SOCKET, SOCKET WRENCH, 1" DR, 2-1/4"	1	E	3	16	
SOCKET, SOCKET WRENCH, 1" DR, 2-3/8"	1	E	3	17	
SOCKET, SOCKET WRENCH, 1" DR, 2-1/2 "	1	E	3	18	

TM 9-4910-783-13&P

SATS FMM1 TOOL INVENTORY LIST

0059 00

INVENTORY

NOMENCLATURE	QTY	RACK	DRAWER	LOCATION	AMOUNT
SOCKET, IMPACT WRENCH, 1/2" DR, 6 PT, DEEP, 12MM	1	E	4	1	
SOCKET, IMPACT WRENCH, 1/2" DR, 6 PT, DEEP, 13MM	1	E	4	2	
SOCKET, IMPACT WRENCH, 1/2" DR, 6 PT, DEEP, 14MM	1	E	4	3	
SOCKET, IMPACT WRENCH, 1/2" DR, 6 PT, DEEP, 15MM	1	E	4	4	
SOCKET, IMPACT WRENCH, 1/2" DR, 6 PT, DEEP, 16MM	1	E	4	5	
SOCKET, IMPACT WRENCH, 1/2" DR, 6 PT, DEEP, 17MM	1	E	4	6	
SOCKET, IMPACT WRENCH, 1/2" DR, 6 PT, DEEP, 18MM	1	E	4	7	
SOCKET, IMPACT WRENCH, 1/2" DR, 6 PT, DEEP, 19MM	1	E	4	8	
SOCKET, IMPACT WRENCH, 1/2" DR, 6 PT, DEEP, 21MM	1	E	4	9	
SOCKET, IMPACT WRENCH, 1/2" DR, 6 PT, DEEP, 22MM	1	E	4	10	
SOCKET, IMPACT WRENCH, 1/2" DR, 6 PT, DEEP, 24MM	1	E	4	11	
SOCKET, IMPACT WRENCH, 1/2" DR, 6 PT, DEEP, 27MM	1	E	4	12	
SOCKET, IMPACT WRENCH, 1/2" DR, 6 PT, DEEP, 1-1/16"	1	E	4	13	
SOCKET, IMPACT WRENCH, 1/2" DR, 6 PT, DEEP, 1"	1	E	4	14	
SOCKET, IMPACT WRENCH, 1/2" DR, 6 PT, DEEP, 15/16"	1	E	4	15	
SOCKET, IMPACT WRENCH, 1/2" DR, 6 PT, DEEP, 7/8"	1	E	4	16	
SOCKET, IMPACT WRENCH, 1/2" DR, 6 PT, DEEP, 13/16"	1	E	4	17	
SOCKET, IMPACT WRENCH, 1/2" DR, 6 PT, DEEP, 3/4"	1	E	4	18	
SOCKET, IMPACT WRENCH, 1/2" DR, 6 PT, DEEP, 11/16"	1	E	4	19	
SOCKET, IMPACT WRENCH, 1/2" DR, 6 PT, DEEP, 5/8"	1	E	4	20	
SOCKET, IMPACT WRENCH, 1/2" DR, 6 PT, DEEP, 9/16"	1	E	4	21	
SOCKET, IMPACT WRENCH, 1/2" DR, 6 PT, DEEP, 1/2"	1	E	4	22	
SOCKET, IMPACT WRENCH, 1/2" DR, 6 PT, DEEP, 7/16"	1	E	4	23	
SOCKET, DOUBLE-END IMPACT, 3/4" X 13/16"	1	E	4	24	
SOCKET, IMPACT WRENCH, 3/8" DR, 6 PT, DEEP, 12MM	1	E	4	25	
SOCKET, IMPACT WRENCH, 3/8" DR, 6 PT, DEEP, 11MM	1	E	4	26	
SOCKET, IMPACT WRENCH, 3/8" DR, 6 PT, DEEP, 10MM	1	E	4	27	
SOCKET, IMPACT WRENCH, 3/8" DR, 6 PT, 10MM	1	E	4	28	
SOCKET, IMPACT WRENCH, 3/8" DR, 6 PT, 11MM	1	E	4	29	
SOCKET, IMPACT WRENCH, 3/8" DR, 6 PT, 12MM	1	E	4	30	
SOCKET, IMPACT WRENCH, 3/8" DR, 6 PT, 13MM	1	E	4	31	
SOCKET, IMPACT WRENCH, 3/8" DR, 6 PT, 14MM	1	E	4	32	
SOCKET, IMPACT WRENCH, 3/8" DR, 6 PT, 15MM	1	E	4	33	
SOCKET, IMPACT WRENCH, 3/8" DR, 6 PT, 16MM	1	E	4	34	
SOCKET, IMPACT WRENCH, 3/8" DR, 6 PT, 17MM	1	E	4	35	
SOCKET, IMPACT WRENCH, 3/8" DR, 6 PT, 18MM	1	E	4	36	

TM 9-4910-783-13&P

SATS FMM1 TOOL INVENTORY LIST

0059 00

NOMENCLATURE	QTY	RACK	DRAWER	LOCATION	INVENTORY AMOUNT
SOCKET, IMPACT WRENCH, 3/8" DR, 6 PT, 19MM	1	E	4	37	
SOCKET, IMPACT WRENCH, 1/2" DR, 6 PT, DEEP, 3/8"	1	E	4	38	
SOCKET, IMPACT WRENCH, 3/8" DR, 6 PT, DEEP, 13MM	1	E	4	39	
SOCKET, IMPACT WRENCH, 3/8" DR, 6 PT, DEEP, 14MM	1	E	4	40	
SOCKET, IMPACT WRENCH, 3/8" DR, 6 PT, DEEP, 15MM	1	E	4	41	
SOCKET, IMPACT WRENCH, 3/8" DR, 6 PT, DEEP, 16MM	1	E	4	42	
SOCKET, IMPACT WRENCH, 3/8" DR, 6 PT, DEEP, 17MM	1	E	4	43	
SOCKET, IMPACT WRENCH, 3/8" DR, 6 PT, DEEP, 18MM	1	E	4	44	
SOCKET, IMPACT WRENCH, 3/8" DR, 6 PT, DEEP, 19MM	1	E	4	45	
SOCKET, IMPACT WRENCH, 3/8" DR, 6 PT, 3/4"	1	E	4	46	
SOCKET, IMPACT WRENCH, 3/8" DR, 6 PT, 11/16"	1	E	4	47	
SOCKET, IMPACT WRENCH, 3/8" DR, 6 PT, 5/8"	1	E	4	48	
SOCKET, IMPACT WRENCH, 3/8" DR, 6 PT, 9/16"	1	E	4	49	
SOCKET, IMPACT WRENCH, 3/8" DR, 6 PT, 1/2"	1	E	4	50	
SOCKET, IMPACT WRENCH, 3/8" DR, 6 PT, 7/16"	1	E	4	51	
SOCKET, IMPACT WRENCH, 1/2" DR, 6 PT, 12MM	1	E	4	52	
SOCKET, IMPACT WRENCH, 3/8" DR, 6 PT, DEEP, 3/4"	1	E	4	53	
SOCKET, IMPACT WRENCH, 3/8" DR, 6 PT, DEEP, 11/16"	1	E	4	54	
SOCKET, IMPACT WRENCH, 3/8" DR, 6 PT, DEEP, 5/8"	1	E	4	55	
SOCKET, IMPACT WRENCH, 3/8" DR, 6 PT, DEEP, 9/16"	1	E	4	56	
SOCKET, IMPACT WRENCH, 3/8" DR, 6 PT, DEEP, 1/2"	1	E	4	57	
SOCKET, IMPACT WRENCH, 3/8" DR, 6 PT, DEEP, 7/16"	1	E	4	58	
SOCKET, IMPACT WRENCH, 3/8" DR, 6 PT, DEEP, 3/8"	1	E	4	59	
SOCKET, IMPACT WRENCH, 3/8" DR, 6 PT, DEEP, 5/16"	1	E	4	60	
SOCKET, IMPACT WRENCH, 3/8" DR, 6 PT, DEEP, 1/4"	1	E	4	61	
SOCKET, IMPACT WRENCH, 3/8" DR, 6 PT, 3/8"	1	E	4	62	
SOCKET, IMPACT WRENCH, 1/2" DR, 6 PT, 13MM	1	E	4	63	
SOCKET, IMPACT WRENCH, 1/2" DR, 6 PT, 5/8"	1	E	4	64	
SOCKET, IMPACT WRENCH, 1/2" DR, 6 PT, 11/16"	1	E	4	65	
SOCKET, IMPACT WRENCH, 3/8" DR, 6 PT, 1/4"	1	E	4	66	
SOCKET, IMPACT WRENCH, 3/8" DR, 6 PT, 5/16"	1	E	4	67	
SOCKET, IMPACT WRENCH, 1/2" DR, 6 PT, 14MM	1	E	4	68	
SOCKET, IMPACT WRENCH, 1/2" DR, 6 PT, 3/8"	1	E	4	69	
SOCKET, IMPACT WRENCH, 1/2" DR, 6 PT, 7/16"	1	E	4	70	
SOCKET, IMPACT WRENCH, 1/2" DR, 6 PT, 1/2"	1	E	4	71	
SOCKET, IMPACT WRENCH, 1/2" DR, 6 PT, 9/16"	1	E	4	72	
SOCKET, IMPACT WRENCH, 1/2" DR, 6 PT, 3/4"	1	E	4	73	

TM 9-4910-783-13&P

SATS FMM1 TOOL INVENTORY LIST

0059 00

NOMENCLATURE	INVENTORY				AMOUNT
	QTY	RACK	DRAWER	LOCATION	
SOCKET, IMPACT WRENCH, 1/2" DR, 6 PT, 15MM	1	E	4	74	
SOCKET, IMPACT WRENCH, 1/2" DR, 6 PT, 1-1/16"	1	E	4	75	
SOCKET, IMPACT WRENCH, 1/2" DR, 6 PT, 1"	1	E	4	76	
SOCKET, IMPACT WRENCH, 1/2" DR, 6 PT, 15/16"	1	E	4	77	
SOCKET, IMPACT WRENCH, 1/2" DR, 6 PT, 7/8"	1	E	4	78	
SOCKET, IMPACT WRENCH, 1/2" DR, 6 PT, 13/16"	1	E	4	79	
BAR, EXTENSION, 1/2" DR, 2.5"	1	E	4	80	
SOCKET, IMPACT WRENCH, 1/2" DR, 6 PT, 16MM	1	E	4	81	
WRENCH, ELECTRIC IMPACT, 1/2" SQ DR,	1	E	4	82	
BAR, EXTENSION, 1/2" DR, 4.55"	1	E	4	83	
JOINT, UNIVERSAL, 1/2" DR	1	E	4	84	
BAR, EXTENSION, 1/2" DR, 9.5"	1	E	4	85	
SOCKET, IMPACT WRENCH, 1/2" DR, 6 PT, 17MM	1	E	4	86	
BAR, EXTENSION, IMPACT WRENCH, 3/8" DR, 5.5"	1	E	4	87	
ADAPTER, 3/8" DR MALE TO 1/2" DR FEMALE	1	E	4	88	
JOINT, UNIVERSAL, 3/8" DR	1	E	4	89	
SOCKET, IMPACT WRENCH, 1/2" DR, 6 PT, 18MM	1	E	4	90	
BAR, EXTENSION, IMPACT WRENCH, 3/8" DR, 2.5"	1	E	4	91	
WRENCH, PNEUMATIC IMPACT, 1/2" SQ DR,	1	E	4	92	
SOCKET, IMPACT WRENCH, 1/2" DR, 6 PT, 19MM	1	E	4	93	
SOCKET, IMPACT WRENCH, 1/2" DR, 6 PT, 21MM	1	E	4	94	
SOCKET, IMPACT WRENCH, 1/2" DR, 6 PT, 22MM	1	E	4	95	
SOCKET, IMPACT WRENCH, 1/2" DR, 6 PT, 24MM	1	E	4	96	
SOCKET, IMPACT WRENCH, 1/2" DR, 6 PT, 27MM	1	E	4	97	

TM 9-4910-783-13&P

SATS FMM1 TOOL INVENTORY LIST

0059 00

NOMENCLATURE	QTY	RACK	DRAWER	LOCATION	INVENTORY AMOUNT
CALIPER, MICROMETER, INSIDE	1	E	5	1	
WRENCH, TORQUE, DIAL, 3/8", 300 LB-IN Nm	1	E	5	2	
WRENCH, TORQUE, DIAL, 1/4", 30 LB-IN Nm	1	E	5	3	
INDICATOR, DIAL	1	E	5	6	
CALIPER, VERNIER	1	E	5	8	
GAGE, STOCK SET, THICKNESS	1	E	5	4,5,7	

E, 5

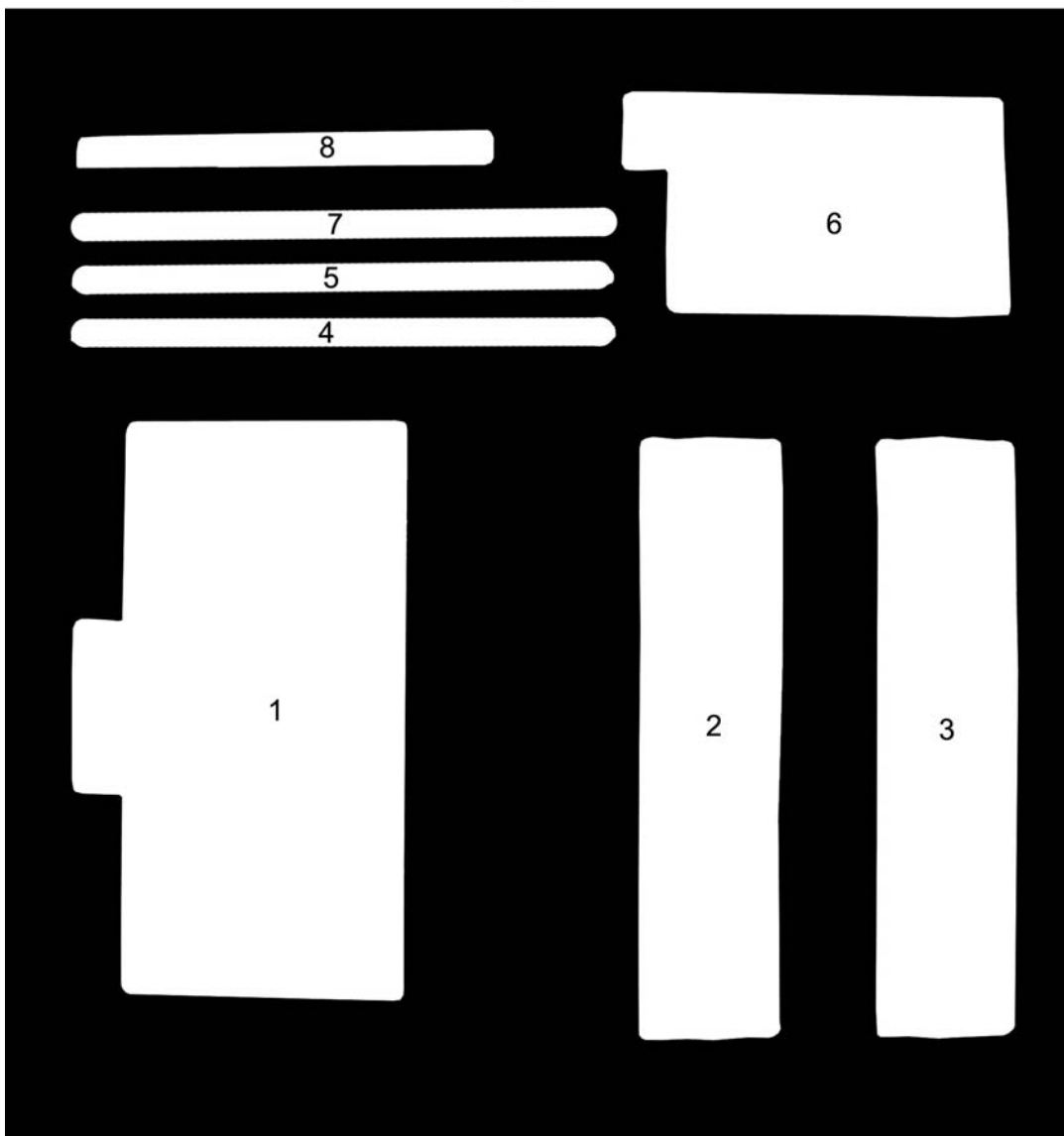

TM 9-4910-783-13&P

SATS FMM1 TOOL INVENTORY LIST

0059 00

NOMENCLATURE	QTY	RACK	DRAWER	LOCATION	INVENTORY AMOUNT
PULLER, PITTMAN ARM	1	E	6	1	
BEARING CUP PULLER ATTACHMENT	1	E	6	2	
BEARING SPLITTER, 4-5/8" MAX	1	E	6	3	
2-JAW PULLER, 13 TON, 11"	1	E	6	4	
BEARING SPLITTER 15/16" MAX	1	E	6	5	
BEARING SPLITTER, 2" MAX	1	E	6	6	
2-JAW PULLER, 2 TON, 3-1/4"	1	E	6	7	
2-JAW PULLER, 7 TON, 5"	1	E	6	8	
2-JAW PULLER, 5 TON, 3-1/4"	1	E	6	9	
PULLER SET, MECHANICAL	1	E	6	1-9	

E, 6

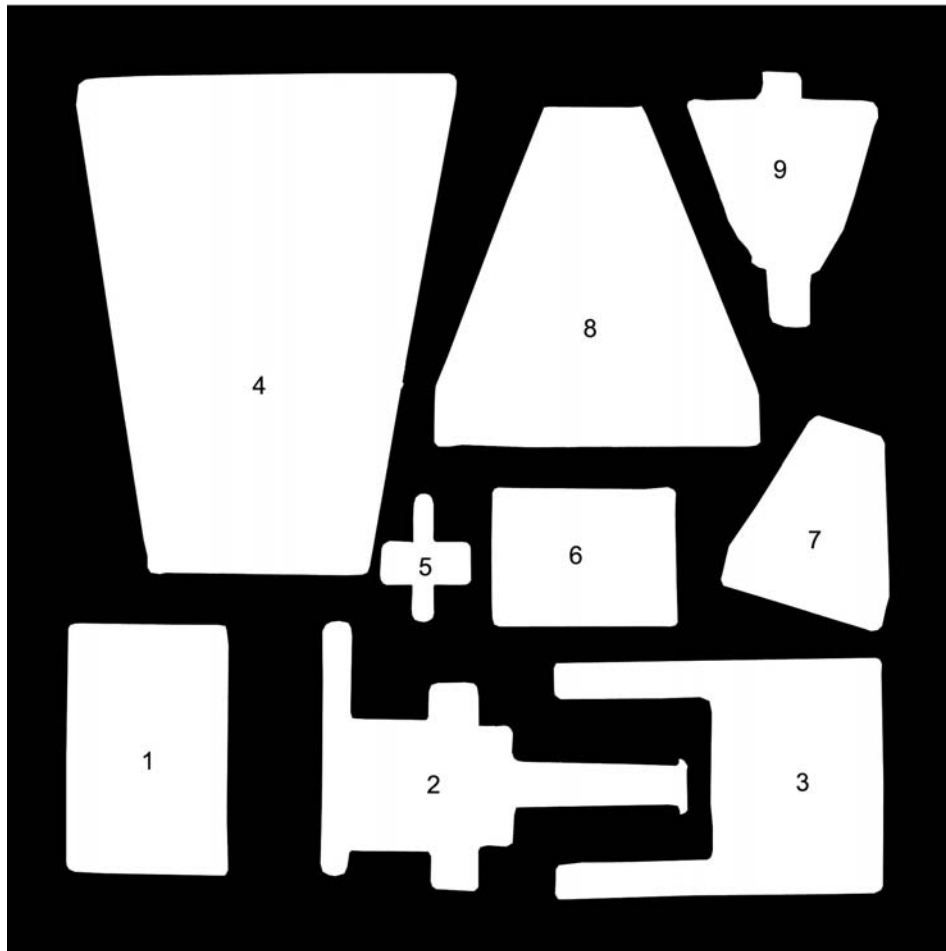

TM 9-4910-783-13&P

E, 7

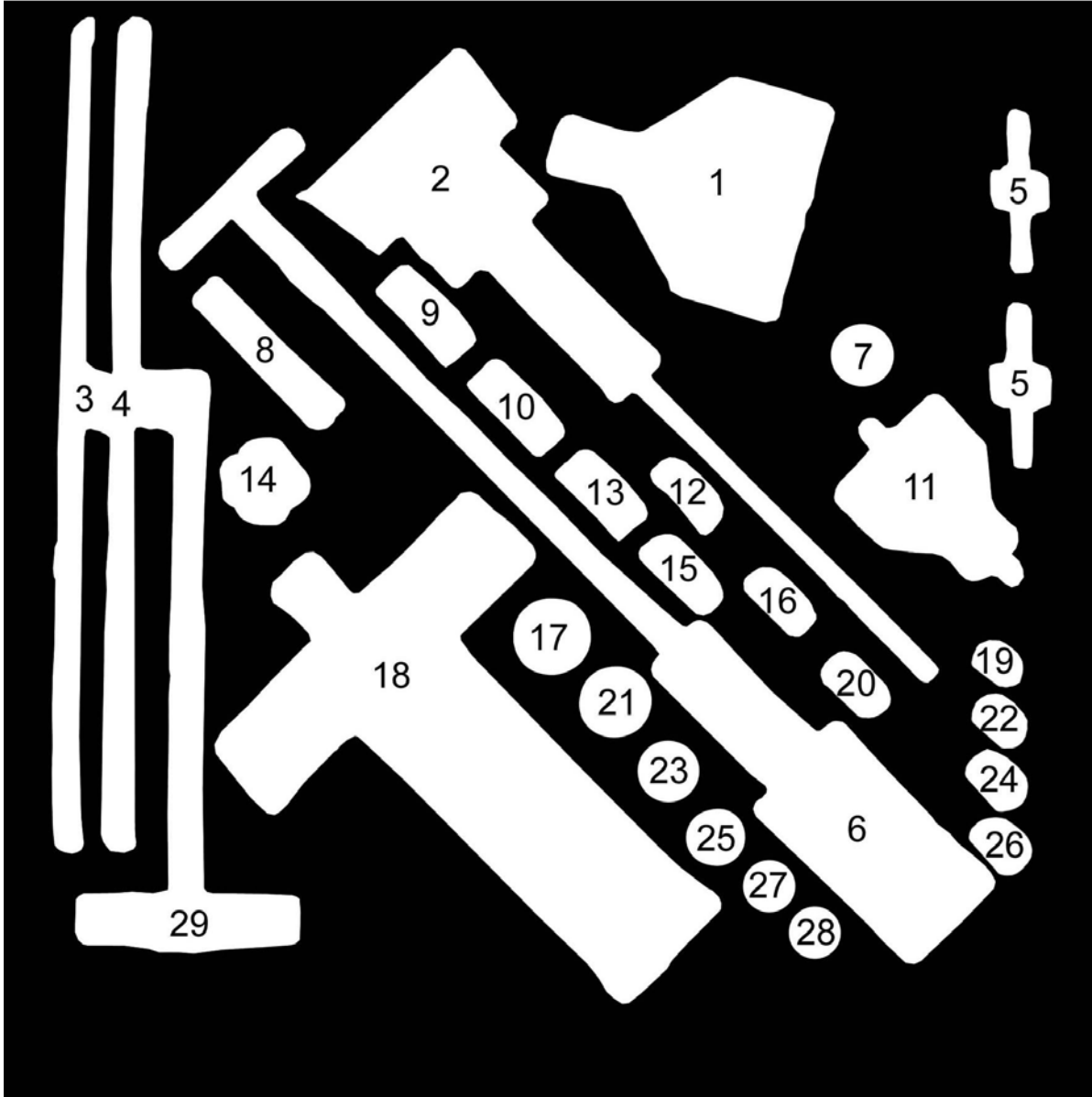

TM 9-4910-783-13&P

SATS FMM1 TOOL INVENTORY LIST

0059 00

NOMENCLATURE	QTY	RACK	DRAWER	LOCATION	INVENTORY AMOUNT
FLANGE-TYPE PULLER	1	E	7	1	
PILOT BEARING PULLER	1	E	7	2	
EXTENSION ROD	1	E	7	3	
EXTENSION ROD	1	E	7	4	
BOLTS – TWO LOCATIONS NUMBERED AS 5	1	E	7	5	
SLIDE HAMMER PULLER	1	E	7	6	
BOLTS FOR MECHANICAL PULLER SET	1	E	7	7	
BOLTS FOR SLIDE HAMMER PULLER	1	E	7	8	
STEP PLATE ADAPTER, 2-1/2"	1	E	7	9	
STEP PLATE ADAPTER, 2-3/8"	1	E	7	10	
STEERING WHEEL PULLER	1	E	7	11	
STEP PLATE ADAPTER, 1-7/8"	1	E	7	12	
STEP PLATE ADAPTER, 2-1/8"	1	E	7	13	
FEMALE THREADED ADAPTER, 1/2"	1	E	7	14	
STEP PLATE ADAPTER, 2"	1	E	7	15	
STEP PLATE ADAPTER, 1-3/4"	1	E	7	16	
FEMALE THREADED ADAPTER, 1-1/4"	1	E	7	17	
PUSH PULLER W/ 6-3/4" LEGS	1	E	7	18	
STEP PLATE ADAPTER, 1"	1	E	7	19	
STEP PLATE ADAPTER, 1-5/8"	1	E	7	20	
FEMALE THREADED ADAPTER, 1-1/8"	1	E	7	21	
STEP PLATE ADAPTER, 1 1/8"	1	E	7	22	
FEMALE THREADED ADAPTER, 1"	1	E	7	23	
STEP PLATE ADAPTER, 1-1/4"	1	E	7	24	
FEMALE THREADED ADAPTER, 7/8"	1	E	7	25	
STEP PLATE ADAPTER, 1-3/8"	1	E	7	26	
FEMALE THREADED ADAPTER, 3/4"	1	E	7	27	
FEMALE THREADED ADAPTER, 5/8"	1	E	7	28	
GEAR AND PULLEY PULLERS, 13"	1	E	7	29	
PULLER SET, MECHANICAL	1	E	7	1-29	

TM 9-4910-783-13&P

F, 1

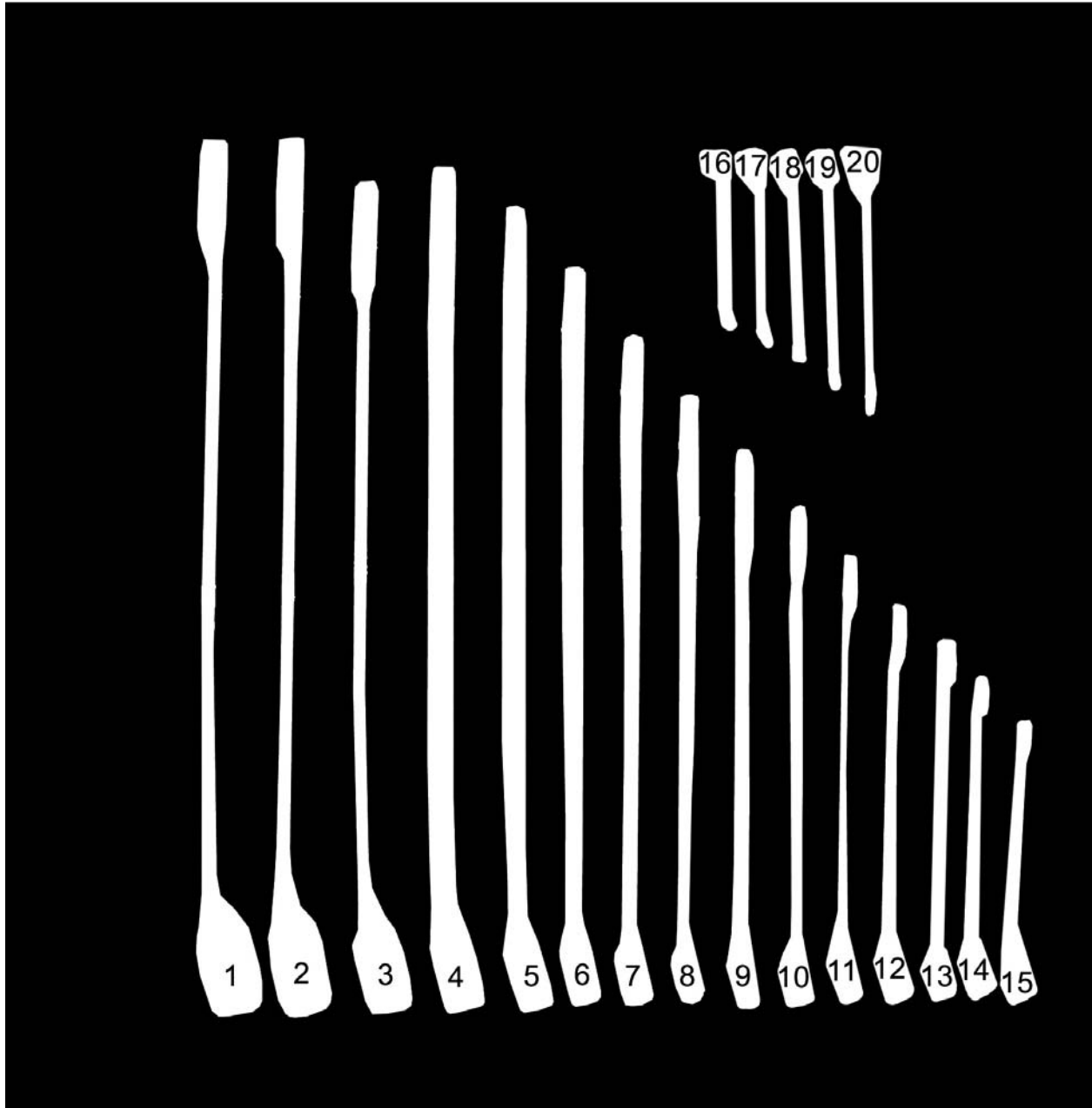

TM 9-4910-783-13&P

SATS FMM1 TOOL INVENTORY LIST

0059 00

INVENTORY

NOMENCLATURE	QTY	RACK	DRAWER	LOCATION	AMOUNT
WRENCH, COMBINATION, 1-1/2"	1	F	1	1	
WRENCH, COMBINATION, 1-7/16"	1	F	1	2	
WRENCH, COMBINATION, 1-3/8"	1	F	1	3	
WRENCH, COMBINATION, 1-5/16"	1	F	1	4	
WRENCH, COMBINATION, 1-1/4"	1	F	1	5	
WRENCH, COMBINATION, 1-1/8"	1	F	1	6	
WRENCH, COMBINATION, 1-1/16"	1	F	1	7	
WRENCH, COMBINATION, 1"	1	F	1	8	
WRENCH, COMBINATION, 15/16"	1	F	1	9	
WRENCH, COMBINATION, 7/8"	1	F	1	10	
WRENCH, COMBINATION, 13/16"	1	F	1	11	
WRENCH, COMBINATION, 3/4"	1	F	1	12	
WRENCH, COMBINATION, 11/16"	1	F	1	13	
WRENCH, COMBINATION, 5/8"	1	F	1	14	
WRENCH, COMBINATION, 9/16"	1	F	1	15	
WRENCH, COMBINATION, 1/4"	1	F	1	16	
WRENCH, COMBINATION, 5/16"	1	F	1	17	
WRENCH, COMBINATION, 3/8"	1	F	1	18	
WRENCH, COMBINATION, 7/16"	1	F	1	19	
WRENCH, COMBINATION, 1/2"	1	F	1	20	

TM 9-4910-783-13&P

SATS FMM1 TOOL INVENTORY LIST

0059 00

NOMENCLATURE	INVENTORY				
	QTY	RACK	DRAWER	LOCATION	AMOUNT
WRENCH, COMBINATION, 2"	1	F	2	1	
WRENCH, COMBINATION, 1-7/8"	1	F	2	2	
WRENCH, COMBINATION, 1-13/16"	1	F	2	3	
WRENCH, COMBINATION, 1-3/4"	1	F	2	4	
WRENCH, COMBINATION, 1-11/16"	1	F	2	5	
WRENCH, COMBINATION, 1-5/8"	1	F	2	6	

F, 2

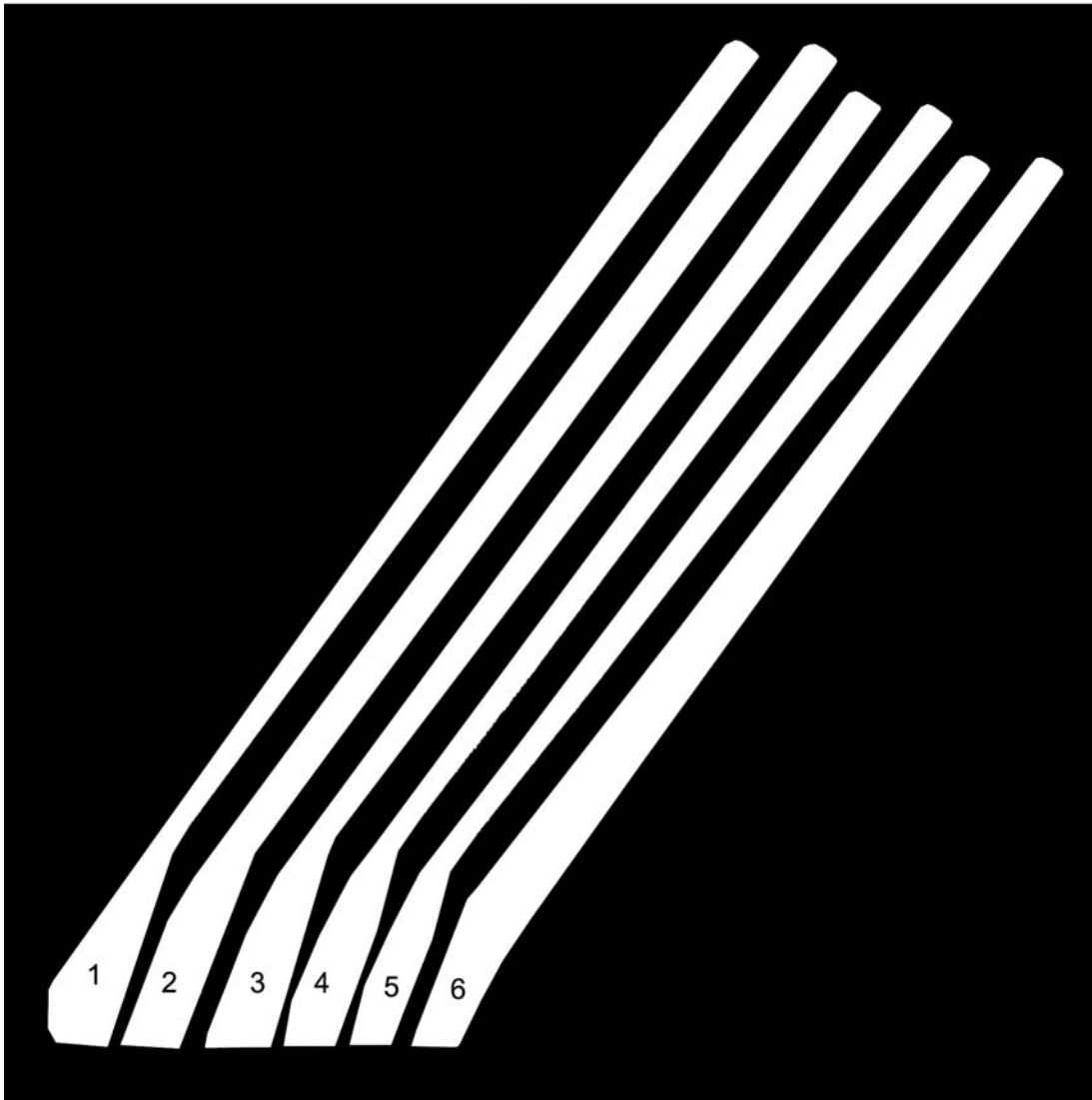

TM 9-4910-783-13&P

SATS FMM1 TOOL INVENTORY LIST

0059 00

THIS PAGE INTENTIONALLY LEFT BLANK

TM 9-4910-783-13&P

F, 3

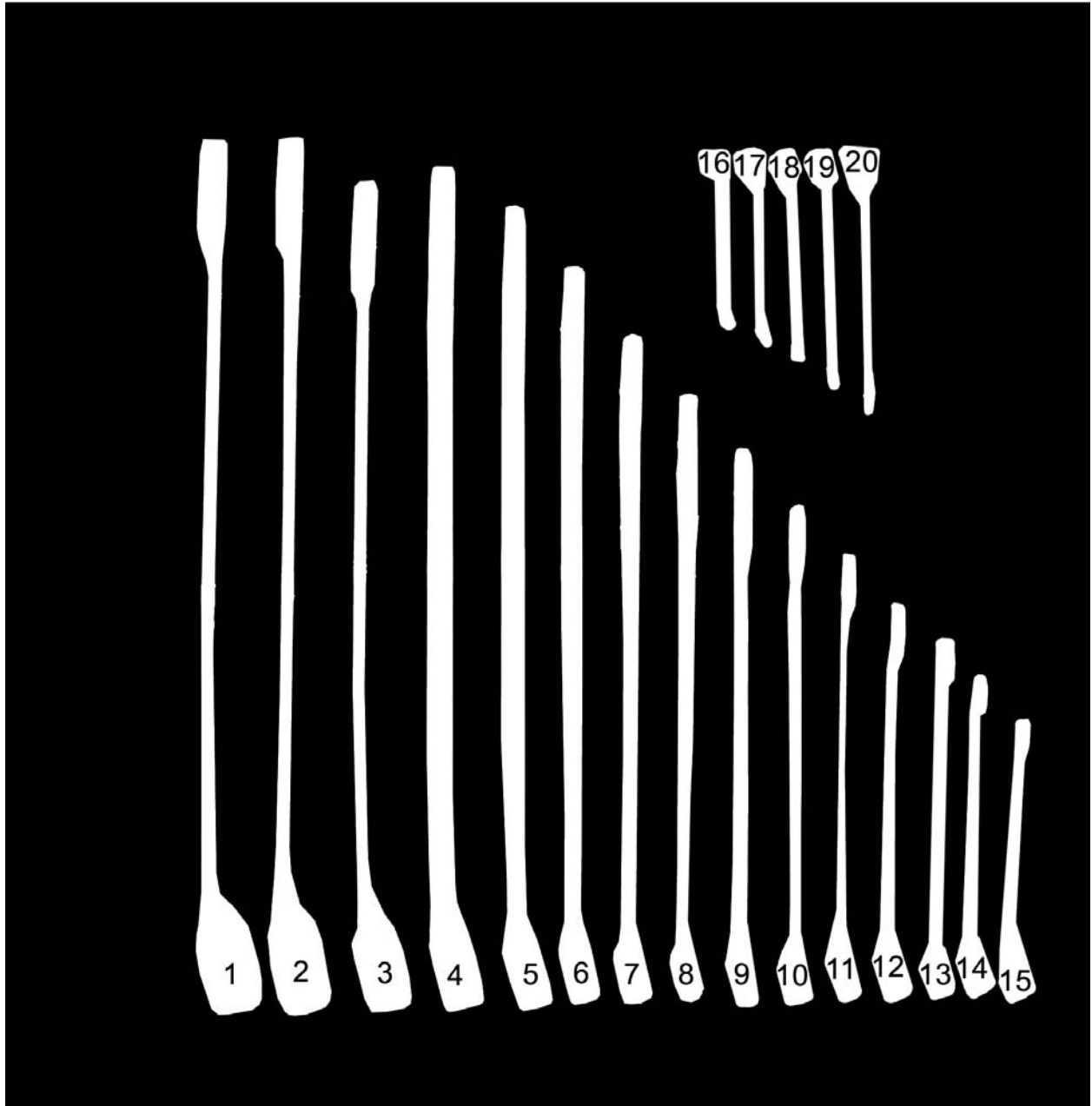

TM 9-4910-783-13&P

SATS FMM1 TOOL INVENTORY LIST

0059 00

INVENTORY

NOMENCLATURE	QTY	RACK	DRAWER	LOCATION	AMOUNT
WRENCH, COMBINATION, 1-1/2"	1	F	3	1	
WRENCH, COMBINATION, 1-7/16"	1	F	3	2	
WRENCH, COMBINATION, 1-3/8"	1	F	3	3	
WRENCH, COMBINATION, 1-5/16"	1	F	3	4	
WRENCH, COMBINATION, 1-1/4"	1	F	3	5	
WRENCH, COMBINATION, 1-1/8"	1	F	3	6	
WRENCH, COMBINATION, 1-1/16"	1	F	3	7	
WRENCH, COMBINATION, 1"	1	F	3	8	
WRENCH, COMBINATION, 15/16"	1	F	3	9	
WRENCH, COMBINATION, 7/8"	1	F	3	10	
WRENCH, COMBINATION, 13/16"	1	F	3	11	
WRENCH, COMBINATION, 3/4"	1	F	3	12	
WRENCH, COMBINATION, 11/16"	1	F	3	13	
WRENCH, COMBINATION, 5/8"	1	F	3	14	
WRENCH, COMBINATION, 9/16"	1	F	3	15	
WRENCH, COMBINATION, 1/4"	1	F	3	16	
WRENCH, COMBINATION, 5/16"	1	F	3	17	
WRENCH, COMBINATION, 3/8"	1	F	3	18	
WRENCH, COMBINATION, 7/16"	1	F	3	19	
WRENCH, COMBINATION, 1/2"	1	F	3	20	

TM 9-4910-783-13&P

SATS FMM1 TOOL INVENTORY LIST

0059 00

NOMENCLATURE	INVENTORY				
	QTY	RACK	DRAWER	LOCATION	AMOUNT
WRENCH, COMBINATION, 2"	1	F	4	1	
WRENCH, COMBINATION, 1-7/8"	1	F	4	2	
WRENCH, COMBINATION, 1-13/16"	1	F	4	3	
WRENCH, COMBINATION, 1-3/4"	1	F	4	4	
WRENCH, COMBINATION, 1-11/16"	1	F	4	5	
WRENCH, COMBINATION, 1-5/8"	1	F	4	6	

F, 4

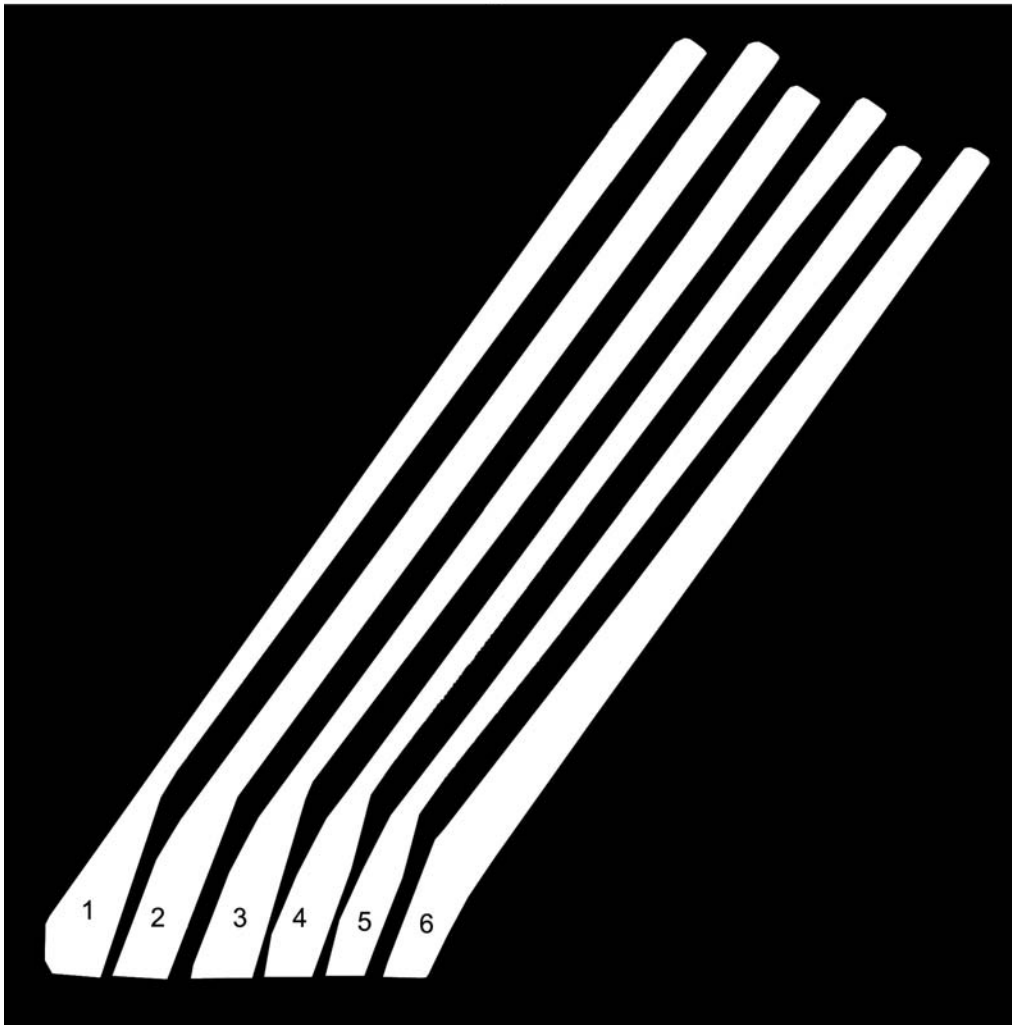

TM 9-4910-783-13&P

SATS FMM1 TOOL INVENTORY LIST

0059 00

THIS PAGE INTENTIONALLY LEFT BLANK

TM 9-4910-783-13&P

F, 5

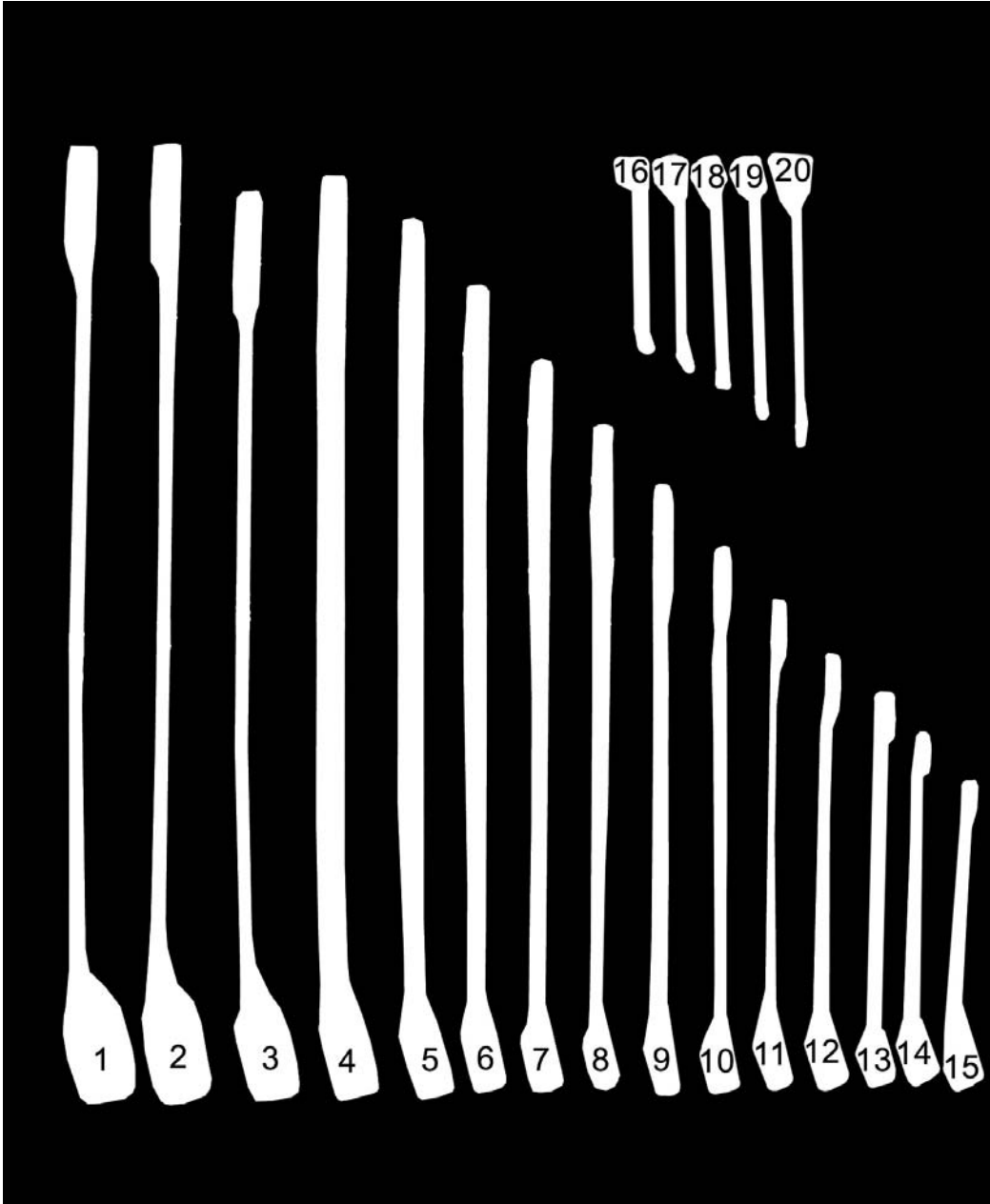

TM 9-4910-783-13&P

SATS FMM1 TOOL INVENTORY LIST

0059 00

					INVENTORY
NOMENCLATURE	QTY	RACK	DRAWER	LOCATION	AMOUNT
WRENCH, COMBINATION, 1-1/2"	1	F	5	1	
WRENCH, COMBINATION, 1-7/16"	1	F	5	2	
WRENCH, COMBINATION, 1-3/8"	1	F	5	3	
WRENCH, COMBINATION, 1-5/16"	1	F	5	4	
WRENCH, COMBINATION, 1-1/4"	1	F	5	5	
WRENCH, COMBINATION, 1-1/8"	1	F	5	6	
WRENCH, COMBINATION, 1-1/16"	1	F	5	7	
WRENCH, COMBINATION, 1"	1	F	5	8	
WRENCH, COMBINATION, 15/16"	1	F	5	9	
WRENCH, COMBINATION, 7/8"	1	F	5	10	
WRENCH, COMBINATION, 13/16"	1	F	5	11	
WRENCH, COMBINATION, 3/4"	1	F	5	12	
WRENCH, COMBINATION, 11/16"	1	F	5	13	
WRENCH, COMBINATION, 5/8"	1	F	5	14	
WRENCH, COMBINATION, 9/16"	1	F	5	15	
WRENCH, COMBINATION, 1/4"	1	F	5	16	
WRENCH, COMBINATION, 5/16"	1	F	5	17	
WRENCH, COMBINATION, 3/8"	1	F	5	18	
WRENCH, COMBINATION, 7/16"	1	F	5	19	
WRENCH, COMBINATION, 1/2"	1	F	5	20	

TM 9-4910-783-13&P

SATS FMM1 TOOL INVENTORY LIST

0059 00

INVENTORY

NOMENCLATURE	QTY	RACK	DRAWER	LOCATION	AMOUNT
WRENCH, COMBINATION, 2"	1	F	6	1	
WRENCH, COMBINATION, 1-7/8"	1	F	6	2	
WRENCH, COMBINATION, 1-9/16"	1	F	6	3	
WRENCH, COMBINATION, 1-3/4"	1	F	6	4	
WRENCH, COMBINATION, 1-11/16"	1	F	6	5	
WRENCH, COMBINATION, 1-5/8"	1	F	6	6	

F, 6

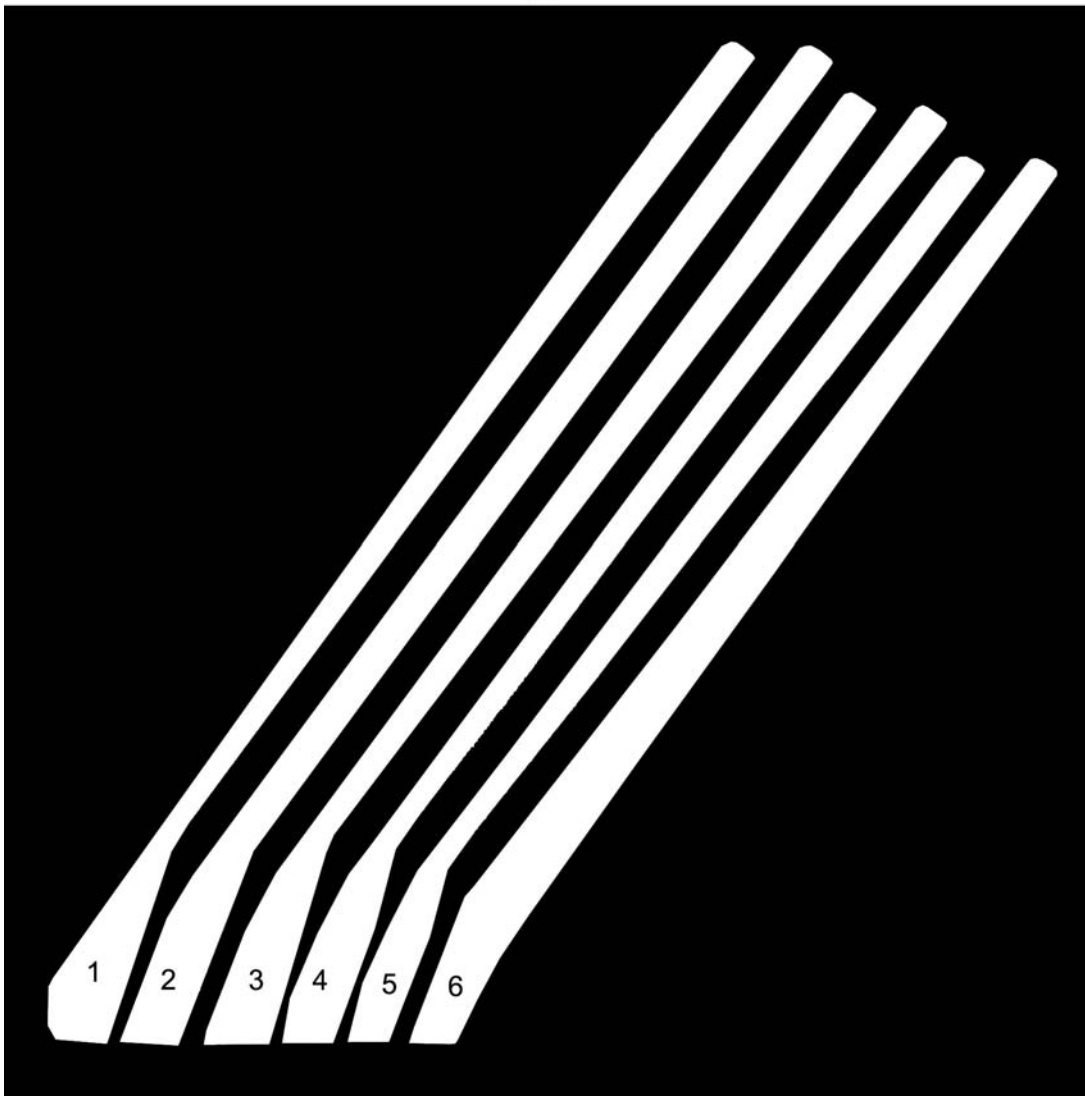

TM 9-4910-783-13&P

SATS FMM1 TOOL INVENTORY LIST

0059 00

THIS PAGE INTENTIONALLY LEFT BLANK

TM 9-4910-783-13&P

F, 7

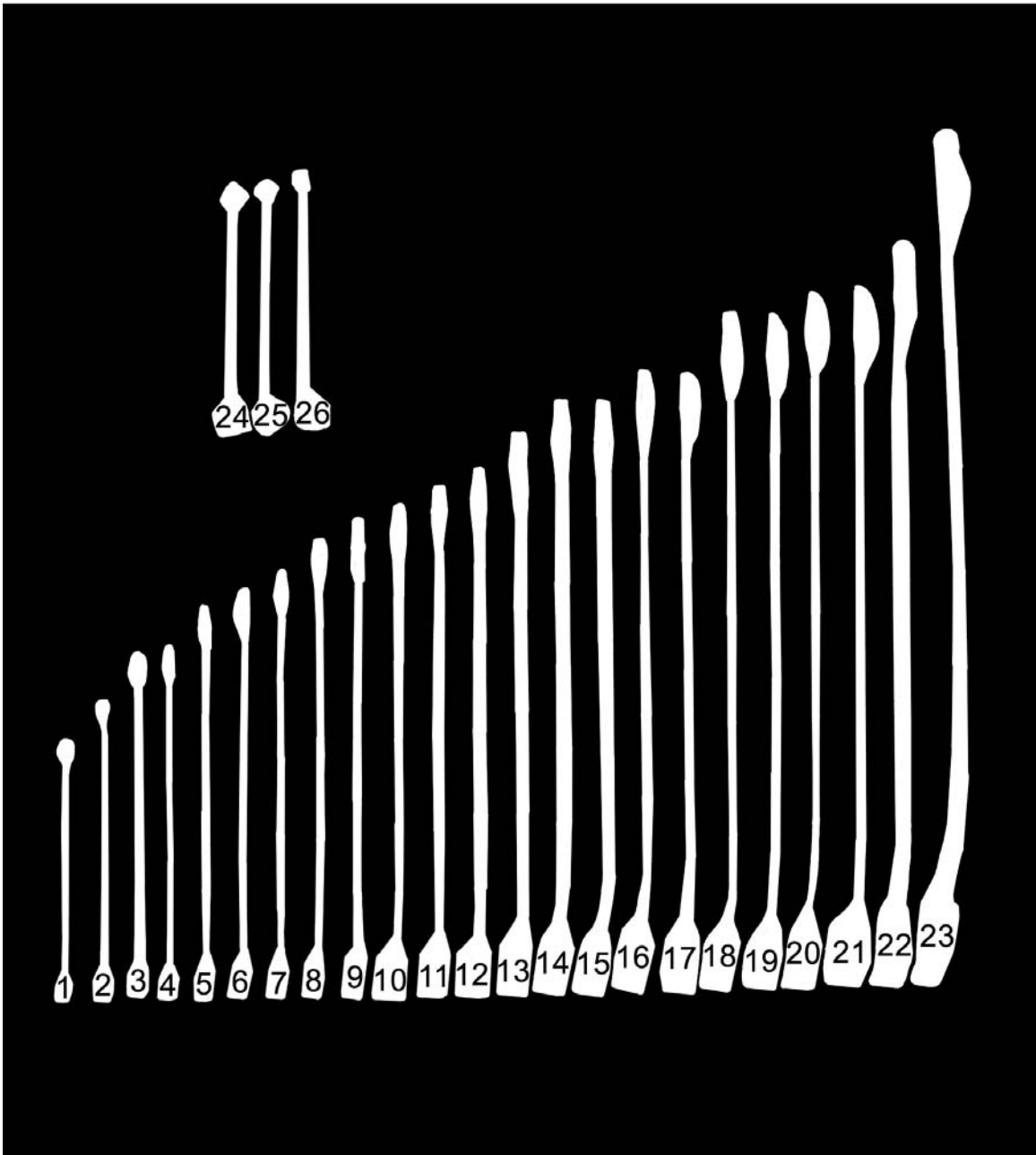

TM 9-4910-783-13&P

SATS FMM1 TOOL INVENTORY LIST

0059 00

					INVENTORY
NOMENCLATURE	QTY	RACK	DRAWER	LOCATION	AMOUNT
WRENCH, COMBINATION, 10MM	1	F	7	1	
WRENCH, COMBINATION, 11MM	1	F	7	2	
WRENCH, COMBINATION, 12MM	1	F	7	3	
WRENCH, COMBINATION, 13MM	1	F	7	4	
WRENCH, COMBINATION, 14MM	1	F	7	5	
WRENCH, COMBINATION, 15MM	1	F	7	6	
WRENCH, COMBINATION, 16MM	1	F	7	7	
WRENCH, COMBINATION, 17MM	1	F	7	8	
WRENCH, COMBINATION, 18MM	1	F	7	9	
WRENCH, COMBINATION, 19MM	1	F	7	10	
WRENCH, COMBINATION, 20MM	1	F	7	11	
WRENCH, COMBINATION, 21MM	1	F	7	12	
WRENCH, COMBINATION, 22MM	1	F	7	13	
WRENCH, COMBINATION, 23MM	1	F	7	14	
WRENCH, COMBINATION, 24MM	1	F	7	15	
WRENCH, COMBINATION, 25MM	1	F	7	16	
WRENCH, COMBINATION, 26MM	1	F	7	17	
WRENCH, COMBINATION, 27MM	1	F	7	18	
WRENCH, COMBINATION, 28MM	1	F	7	19	
WRENCH, COMBINATION, 29MM	1	F	7	20	
WRENCH, COMBINATION, 30MM	1	F	7	21	
WRENCH, COMBINATION, 32MM	1	F	7	22	
WRENCH, COMBINATION, 36MM	1	F	7	23	
WRENCH, COMBINATION, 7MM	1	F	7	24	
WRENCH, COMBINATION, 8MM	1	F	7	25	
WRENCH, COMBINATION, 9MM	1	F	7	26	

TM 9-4910-783-13&P

F, 8

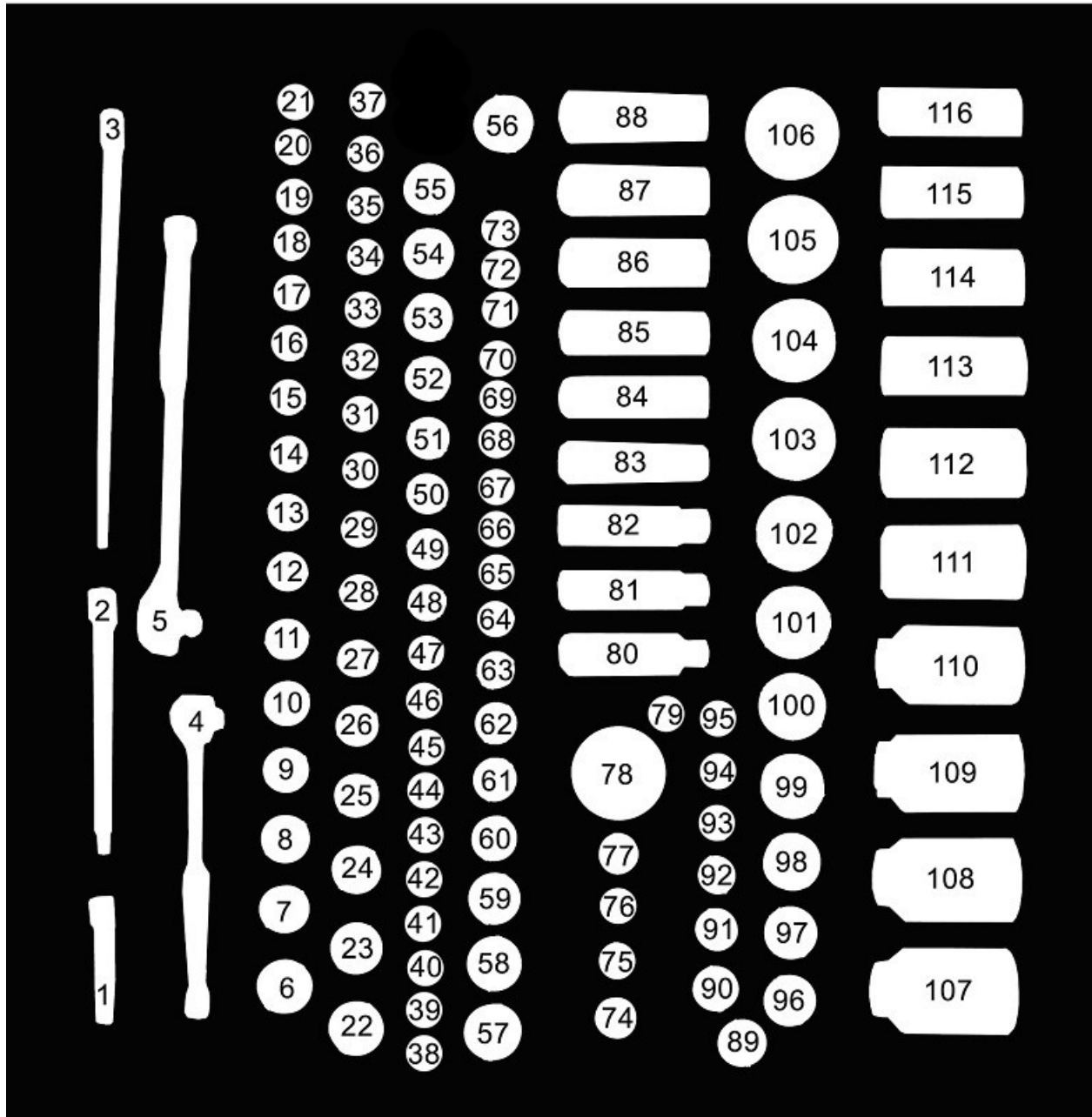

TM 9-4910-783-13&P

SATS FMM1 TOOL INVENTORY LIST

0059 00

NOMENCLATURE	QTY	RACK	DRAWER	LOCATION	INVENTORY AMOUNT
EXTENSION, 3/8" DR, 3" LONG	1	F	8	1	
EXTENSION, 3/8" DR, 6" LONG	1	F	8	2	
EXTENSION, 3/8" DR, 9.5" LONG	1	F	8	3	
HANDLE, RATCHET, 3/8" DR, 6" LONG	1	F	8	4	
HANDLE, RATCHET, 1/2" DR, 10" LONG	1	F	8	5	
SOCKET, SOCKET WRENCH, 3/8" DR, 6 PT, DEEP, 26MM	1	F	8	6	
SOCKET, SOCKET WRENCH, 3/8" DR, 6 PT, DEEP, 23MM	1	F	8	7	
SOCKET, SOCKET WRENCH, 3/8" DR, 6 PT, DEEP, 22MM	1	F	8	8	
SOCKET, SOCKET WRENCH, 3/8" DR, 6 PT, DEEP, 21MM	1	F	8	9	
SOCKET, SOCKET WRENCH, 3/8" DR, 6 PT, DEEP, 20MM	1	F	8	10	
SOCKET, SOCKET WRENCH, 3/8" DR, 6 PT, DEEP, 19MM	1	F	8	11	
SOCKET, SOCKET WRENCH, 3/8" DR, 6 PT, DEEP, 18MM	1	F	8	12	
SOCKET, SOCKET WRENCH, 3/8" DR, 6 PT, DEEP, 17MM	1	F	8	13	
SOCKET, SOCKET WRENCH, 3/8" DR, 6 PT, DEEP, 16MM	1	F	8	14	
SOCKET, SOCKET WRENCH, 3/8" DR, 6 PT, DEEP, 15MM	1	F	8	15	
SOCKET, SOCKET WRENCH, 3/8" DR, 6 PT, DEEP, 14MM	1	F	8	16	
SOCKET, SOCKET WRENCH, 3/8" DR, 6 PT, DEEP, 13MM	1	F	8	17	
SOCKET, SOCKET WRENCH, 3/8" DR, 6 PT, DEEP, 12MM	1	F	8	18	
SOCKET, SOCKET WRENCH, 3/8" DR, 6 PT, DEEP, 11MM	1	F	8	19	
SOCKET, SOCKET WRENCH, 3/8" DR, 6 PT, DEEP, 10MM	1	F	8	20	
SOCKET, SOCKET WRENCH, 3/8" DR, 6 PT, DEEP, 9MM	1	F	8	21	
SOCKET, SOCKET WRENCH, 3/8" DR, 6 PT, DEEP, 1"	1	F	8	22	
SOCKET, SOCKET WRENCH, 3/8" DR, 6 PT, DEEP, 15/16"	1	F	8	23	
SOCKET, SOCKET WRENCH, 3/8" DR, 6 PT, DEEP, 7/8"	1	F	8	24	
SOCKET, SOCKET WRENCH, 3/8" DR, 6 PT, DEEP, 13/16"	1	F	8	25	
SOCKET, SOCKET WRENCH, 3/8" DR, 6 PT, DEEP, 3/4"	1	F	8	26	
SOCKET, SOCKET WRENCH, 3/8" DR, 6 PT, DEEP, 11/16"	1	F	8	27	
SOCKET, SOCKET WRENCH, 3/8" DR, 6 PT, DEEP, 5/8"	1	F	8	28	
SOCKET, SOCKET WRENCH, 3/8" DR, 6 PT, DEEP, 9/16"	1	F	8	29	
SOCKET, SOCKET WRENCH, 3/8" DR, 6 PT, DEEP, 1/2"	1	F	8	30	
SOCKET, SOCKET WRENCH, 3/8" DR, 6 PT, DEEP, 7/16"	1	F	8	31	
SOCKET, SOCKET WRENCH, 3/8" DR, 6 PT, DEEP, 3/8"	1	F	8	32	
SOCKET, SOCKET WRENCH, 3/8" DR, 6 PT, DEEP, 5/16"	1	F	8	33	
SOCKET, SOCKET WRENCH, 3/8" DR, 6 PT, DEEP, 1/4"	1	F	8	34	
SOCKET, SOCKET WRENCH, 3/8" DR, 6 PT, DEEP, 6MM	1	F	8	35	
SOCKET, SOCKET WRENCH, 3/8" DR, 6 PT, DEEP, 7MM	1	F	8	36	

TM 9-4910-783-13&P

SATS FMM1 TOOL INVENTORY LIST

0059 00

NOMENCLATURE	INVENTORY				AMOUNT
	QTY	RACK	DRAWER	LOCATION	
SOCKET, SOCKET WRENCH, 3/8" DR, 6 PT, DEEP, 8MM	1	F	8	37	
SOCKET, SOCKET WRENCH, 3/8" DR, 6 PT, REGULAR, 6MM	1	F	8	38	
SOCKET, SOCKET WRENCH, 3/8" DR, 6 PT, REGULAR, 7MM	1	F	8	39	
SOCKET, SOCKET WRENCH, 3/8" DR, 6 PT, REGULAR, 8MM	1	F	8	40	
SOCKET, SOCKET WRENCH, 3/8" DR, 6 PT, REGULAR, 9MM	1	F	8	41	
SOCKET, SOCKET WRENCH, 3/8" DR, 6 PT, REGULAR, 10MM	1	F	8	42	
SOCKET, SOCKET WRENCH, 3/8" DR, 6 PT, REGULAR, 11MM	1	F	8	43	
SOCKET, SOCKET WRENCH, 3/8" DR, 6 PT, REGULAR, 12MM	1	F	8	44	
SOCKET, SOCKET WRENCH, 3/8" DR, 6 PT, REGULAR, 13MM	1	F	8	45	
SOCKET, SOCKET WRENCH, 3/8" DR, 6 PT, REGULAR, 14MM	1	F	8	46	
SOCKET, SOCKET WRENCH, 3/8" DR, 6 PT, REGULAR, 15MM	1	F	8	47	
SOCKET, SOCKET WRENCH, 3/8" DR, 6 PT, REGULAR, 16MM	1	F	8	48	
SOCKET, SOCKET WRENCH, 3/8" DR, 6 PT, REGULAR, 17MM	1	F	8	49	
SOCKET, SOCKET WRENCH, 3/8" DR, 6 PT, REGULAR, 18MM	1	F	8	50	
SOCKET, SOCKET WRENCH, 3/8" DR, 6 PT, REGULAR, 19MM	1	F	8	51	
SOCKET, SOCKET WRENCH, 3/8" DR, 6 PT, REGULAR, 20MM	1	F	8	52	
SOCKET, SOCKET WRENCH, 3/8" DR, 6 PT, REGULAR, 21MM	1	F	8	53	
SOCKET, SOCKET WRENCH, 3/8" DR, 6 PT, REGULAR, 22MM	1	F	8	54	
SOCKET, SOCKET WRENCH, 3/8" DR, 6 PT, REGULAR, 23MM	1	F	8	55	
SOCKET, SOCKET WRENCH, 3/8" DR, 6 PT, REGULAR, 26MM	1	F	8	56	
SOCKET, SOCKET WRENCH, 3/8" DR, 6 PT, REGULAR, 1"	1	F	8	57	
SOCKET, SOCKET WRENCH, 3/8" DR, 6 PT, REGULAR, 15/16"	1	F	8	58	
SOCKET, SOCKET WRENCH, 3/8" DR, 6 PT, REGULAR, 7/8"	1	F	8	59	
SOCKET, SOCKET WRENCH, 3/8" DR, 6 PT, REGULAR, 13/16"	1	F	8	60	
SOCKET, SOCKET WRENCH, 3/8" DR, 6 PT, REGULAR, 3/4"	1	F	8	61	
SOCKET, SOCKET WRENCH, 3/8" DR, 6 PT, REGULAR, 11/16"	1	F	8	62	
SOCKET, SOCKET WRENCH, 3/8" DR, 6 PT, REGULAR, 5/8"	1	F	8	63	
SOCKET, SOCKET WRENCH, 3/8" DR, 6 PT, REGULAR, 9/16"	1	F	8	64	
SOCKET, SOCKET WRENCH, 3/8" DR, 6 PT, REGULAR, 1/2"	1	F	8	65	
SOCKET, SOCKET WRENCH, 3/8" DR, 6 PT, REGULAR, 7/16"	1	F	8	66	
SOCKET, SOCKET WRENCH, 3/8" DR, 6 PT, REGULAR, 3/8"	1	F	8	67	
SOCKET, SOCKET WRENCH, 3/8" DR, 6 PT, REGULAR, 5/16"	1	F	8	68	
SOCKET, SOCKET WRENCH, 3/8" DR, 6 PT, REGULAR, 1/4"	1	F	8	69	
ADAPTER, SOCKET WRENCH DRIVE, 1/4" MALE - 3/8" FEMALE	1	F	8	70	
ADAPTER, SOCKET WRENCH DRIVE, 1/2" MALE - 3/8" FEMALE	1	F	8	71	
UNIVERSAL, 3/8"	1	F	8	72	
JOINT, UNIVERSAL, 3/8" DR	1	F	8	73	

TM 9-4910-783-13&P

SATS FMM1 TOOL INVENTORY LIST

0059 00

NOMENCLATURE	INVENTORY				AMOUNT
	QTY	RACK	DRAWER	LOCATION	
ADAPTER, SOCKET WRENCH DRIVE, 3/4" MALE - 1/2" FEMALE	1	F	8	74	
ADAPTER, SOCKET WRENCH DRIVE, 3/8" MALE - 1/2" FEMALE	1	F	8	75	
EXTENSION, 1/2" DR, 1-1/2" LONG	1	F	8	76	
JOINT, UNIVERSAL, 1/2" DR	1	F	8	77	
STUD REMOVER, 5/16" - 3/4" CAPACITY	1	F	8	78	
SOCKET, SOCKET WRENCH, 1/2" DR, 6 PT, REGULAR, 3/8"	1	F	8	79	
SOCKET, SOCKET WRENCH, 1/2" DR, 6 PT, DEEP, 3/8"	1	F	8	80	
SOCKET, SOCKET WRENCH, 1/2" DR, 6 PT, DEEP, 7/16"	1	F	8	81	
SOCKET, SOCKET WRENCH, 1/2" DR, 6 PT, DEEP, 1/2"	1	F	8	82	
SOCKET, SOCKET WRENCH, 1/2" DR, 6 PT, DEEP, 9/16"	1	F	8	83	
SOCKET, SOCKET WRENCH, 1/2" DR, 6 PT, DEEP, 5/8"	1	F	8	84	
SOCKET, SOCKET WRENCH, 1/2" DR, 6 PT, DEEP, 11/16"	1	F	8	85	
SOCKET, SOCKET WRENCH, 1/2" DR, 6 PT, DEEP, 3/4"	1	F	8	86	
SOCKET, SOCKET WRENCH, 1/2" DR, 6 PT, DEEP, 13/16"	1	F	8	87	
SOCKET, SOCKET WRENCH, 1/2" DR, 6 PT, DEEP, 7/8"	1	F	8	88	
SOCKET, SOCKET WRENCH, 1/2" DR, 6 PT, REGULAR, 13/16"	1	F	8	89	
SOCKET, SOCKET WRENCH, 1/2" DR, 6 PT, REGULAR, 3/4"	1	F	8	90	
SOCKET, SOCKET WRENCH, 1/2" DR, 6 PT, REGULAR, 11/16"	1	F	8	91	
SOCKET, SOCKET WRENCH, 1/2" DR, 6 PT, REGULAR, 5/8"	1	F	8	92	
SOCKET, SOCKET WRENCH, 1/2" DR, 6 PT, REGULAR, 9/16"	1	F	8	93	
SOCKET, SOCKET WRENCH, 1/2" DR, 6 PT, REGULAR, 1/2"	1	F	8	94	
SOCKET, SOCKET WRENCH, 1/2" DR, 6 PT, REGULAR, 7/16"	1	F	8	95	
SOCKET, SOCKET WRENCH, 1/2" DR, 6 PT, REGULAR, 7/8"	1	F	8	96	
SOCKET, SOCKET WRENCH, 1/2" DR, 6 PT, REGULAR, 15/16"	1	F	8	97	
SOCKET, SOCKET WRENCH, 1/2" DR, 6 PT, REGULAR, 1"	1	F	8	98	
SOCKET, SOCKET WRENCH, 1/2" DR, 6 PT, REGULAR, 1-1/16"	1	F	8	99	
SOCKET, SOCKET WRENCH, 1/2" DR, 6 PT, REGULAR, 1-1/8"	1	F	8	100	
SOCKET, SOCKET WRENCH, 1/2" DR, 6 PT, REGULAR, 1-3/16"	1	F	8	101	
SOCKET, SOCKET WRENCH, 1/2" DR, 6 PT, REGULAR, 1-1/4"	1	F	8	102	
SOCKET, SOCKET WRENCH, 1/2" DR, 6 PT, REGULAR, 1-5/16"	1	F	8	103	
SOCKET, SOCKET WRENCH, 1/2" DR, 6 PT, REGULAR, 1-3/8"	1	F	8	104	
SOCKET, SOCKET WRENCH, 1/2" DR, 6 PT, REGULAR, 1-7/16"	1	F	8	105	
SOCKET, SOCKET WRENCH, 1/2" DR, 6 PT, REGULAR, 1-1/2"	1	F	8	106	
SOCKET, SOCKET WRENCH, 1/2" DR, 6 PT, DEEP, 1-1/2"	1	F	8	107	
SOCKET, SOCKET WRENCH, 1/2" DR, 6 PT, DEEP, 1-7/16"	1	F	8	108	
SOCKET, SOCKET WRENCH, 1/2" DR, 6 PT, DEEP, 1-3/8"	1	F	8	109	
SOCKET, SOCKET WRENCH, 1/2" DR, 6 PT, DEEP, 1-5/16"	1	F	8	110	

TM 9-4910-783-13&P

SATS FMM1 TOOL INVENTORY LIST

0059 00

NOMENCLATURE	INVENTORY				
	QTY	RACK	DRAWER	LOCATION	AMOUNT
SOCKET, SOCKET WRENCH, 1/2" DR, 6 PT, DEEP, 1-1/4"	1	F	8	111	
SOCKET, SOCKET WRENCH, 1/2" DR, 6 PT, DEEP, 1-3/16"	1	F	8	112	
SOCKET, SOCKET WRENCH, 1/2" DR, 6 PT, DEEP, 1-1/8"	1	F	8	113	
SOCKET, SOCKET WRENCH, 1/2" DR, 6 PT, DEEP, 1-1/16"	1	F	8	114	
SOCKET, SOCKET WRENCH, 1/2" DR, 6 PT, DEEP, 1"	1	F	8	115	
SOCKET, SOCKET WRENCH, 1/2" DR, 6 PT, DEEP, 15/16"	1	F	8	116	

TM 9-4910-783-13&P

SATS FMM1 TOOL INVENTORY LIST

0059 00

THIS PAGE INTENTIONALLY LEFT BLANK

TM 9-4910-783-13&P

SATS FMM1 TOOL INVENTORY LIST

0059 00

F, 9

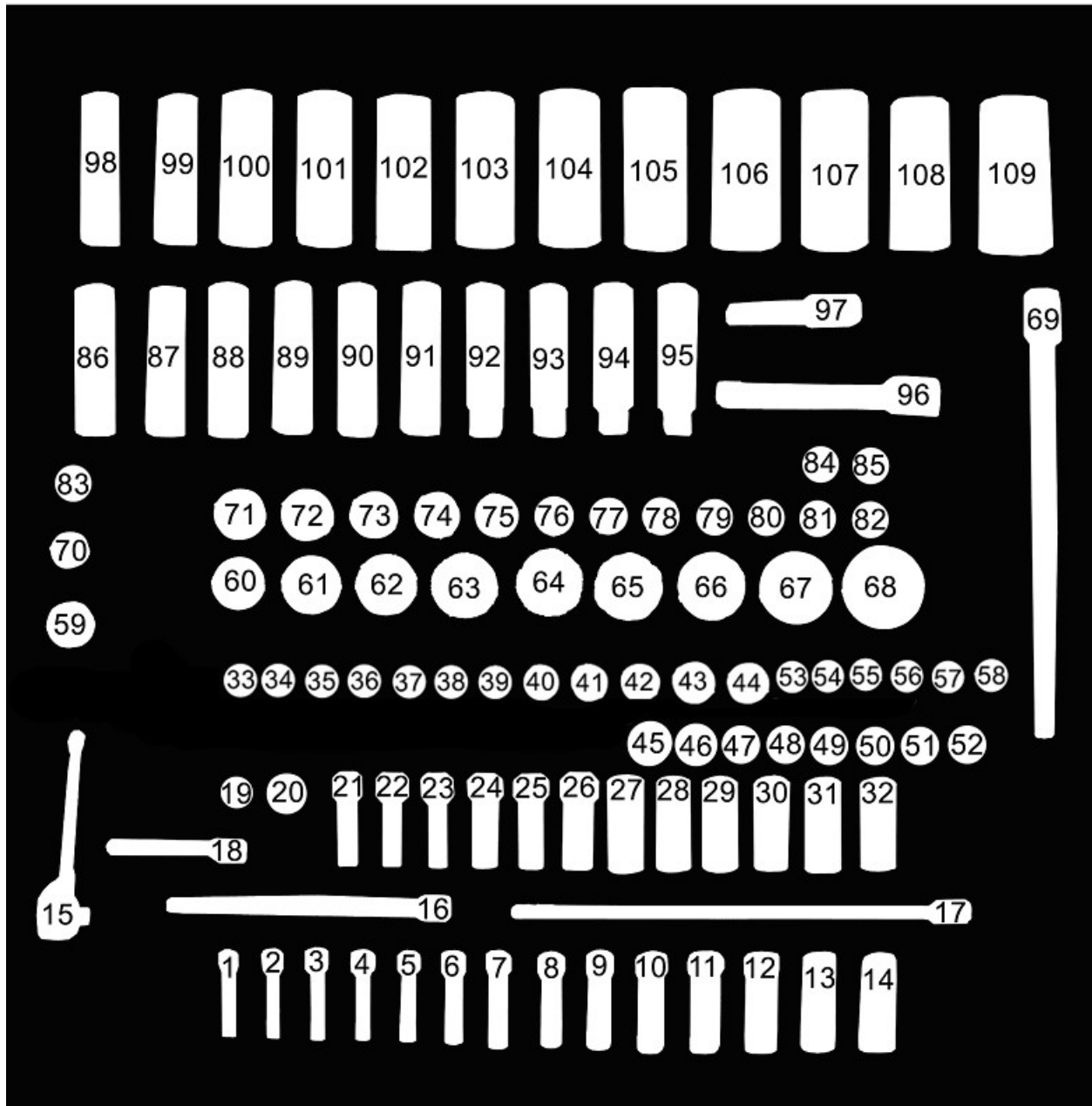

TM 9-4910-783-13&P

SATS FMM1 TOOL INVENTORY LIST

0059 00

INVENTORY

NOMENCLATURE	QTY	RACK	DRAWER	LOCATION	AMOUNT
SOCKET, SOCKET WRENCH, 1/4" DR, 6 PT, DEEP, 4MM	1	F	9	1	
SOCKET, SOCKET WRENCH, 1/4" DR, 6 PT, DEEP, 4.5MM	1	F	9	2	
SOCKET, SOCKET WRENCH, 1/4" DR, 6 PT, DEEP, 5MM	1	F	9	3	
SOCKET, SOCKET WRENCH, 1/4" DR, 6 PT, DEEP, 5.5MM	1	F	9	4	
SOCKET, SOCKET WRENCH, 1/4" DR, 6 PT, DEEP, 6MM	1	F	9	5	
SOCKET, SOCKET WRENCH, 1/4" DR, 6 PT, DEEP, 7MM	1	F	9	6	
SOCKET, SOCKET WRENCH, 1/4" DR, 6 PT, DEEP, 8MM	1	F	9	7	
SOCKET, SOCKET WRENCH, 1/4" DR, 6 PT, DEEP, 9MM	1	F	9	8	
SOCKET, SOCKET WRENCH, 1/4" DR, 6 PT, DEEP, 10MM	1	F	9	9	
SOCKET, SOCKET WRENCH, 1/4" DR, 6 PT, DEEP, 11MM	1	F	9	10	
SOCKET, SOCKET WRENCH, 1/4" DR, 6 PT, DEEP, 12MM	1	F	9	11	
SOCKET, SOCKET WRENCH, 1/4" DR, 6 PT, DEEP, 13MM	1	F	9	12	
SOCKET, SOCKET WRENCH, 1/4" DR, 6 PT, DEEP, 14MM	1	F	9	13	
SOCKET, SOCKET WRENCH, 1/4" DR, 6 PT, DEEP, 15MM	1	F	9	14	
HANDLE, REVERSIBLE RATCHET, SOCKET WRENCH, 1/4" DR, 4.375" DEEP	1	F	9	15	
EXTENSION, 1/4" DR, 6" LONG	1	F	9	16	
EXTENSION, 1/4" DR, 10" LONG	1	F	9	17	
EXTENSION, 1/4" DR, 3" LONG	1	F	9	18	
ADAPTER, SOCKET WRENCH DRIVE, 3/8" MALE - 1/4" FEMALE	1	F	9	19	
JOINT, UNIVERSAL, 1/4" DR	1	F	9	20	
SOCKET, SOCKET WRENCH, 1/4" DR, 6 PT, DEEP, 1/8"	1	F	9	21	
SOCKET, SOCKET WRENCH, 1/4" DR, 6 PT, DEEP, 5/32"	1	F	9	22	
SOCKET, SOCKET WRENCH, 1/4" DR, 6 PT, DEEP, 3/16"	1	F	9	23	
SOCKET, SOCKET WRENCH, 1/4" DR, 6 PT, DEEP, 7/32"	1	F	9	24	
SOCKET, SOCKET WRENCH, 1/4" DR, 6 PT, DEEP, 1/4"	1	F	9	25	
SOCKET, SOCKET WRENCH, 1/4" DR, 6 PT, DEEP, 9/32"	1	F	9	26	
SOCKET, SOCKET WRENCH, 1/4" DR, 6 PT, DEEP, 5/16"	1	F	9	27	
SOCKET, SOCKET WRENCH, 1/4" DR, 6 PT, DEEP, 11/32"	1	F	9	28	
SOCKET, SOCKET WRENCH, 1/4" DR, 6 PT, DEEP, 3/8"	1	F	9	29	
SOCKET, SOCKET WRENCH, 1/4" DR, 6 PT, DEEP, 7/16"	1	F	9	30	
SOCKET, SOCKET WRENCH, 1/4" DR, 6 PT, DEEP, 1/2"	1	F	9	31	
SOCKET, SOCKET WRENCH, 1/4" DR, 6 PT, DEEP, 9/16"	1	F	9	32	
SOCKET, SOCKET WRENCH, 1/4" DR, 6 PT, REGULAR, 9/16"	1	F	9	33	
SOCKET, SOCKET WRENCH, 1/4" DR, 6 PT, REGULAR, 1/2"	1	F	9	34	
SOCKET, SOCKET WRENCH, 1/4" DR, 6 PT, REGULAR, 7/16"	1	F	9	35	
SOCKET, SOCKET WRENCH, 1/4" DR, 6 PT, REGULAR, 3/8"	1	F	9	36	

TM 9-4910-783-13&P

SATS FMM1 TOOL INVENTORY LIST

0059 00

NOMENCLATURE	INVENTORY				AMOUNT
	QTY	RACK	DRAWER	LOCATION	
SOCKET, SOCKET WRENCH, 1/4" DR, 6 PT, REGULAR, 11/32"	1	F	9	37	
SOCKET, SOCKET WRENCH, 1/4" DR, 6 PT, REGULAR, 5/16"	1	F	9	38	
SOCKET, SOCKET WRENCH, 1/4" DR, 6 PT, REGULAR, 9/32"	1	F	9	39	
SOCKET, SOCKET WRENCH, 1/4" DR, 6 PT, REGULAR, 1/4"	1	F	9	40	
SOCKET, SOCKET WRENCH, 1/4" DR, 6 PT, REGULAR, 7/32"	1	F	9	41	
SOCKET, SOCKET WRENCH, 1/4" DR, 6 PT, REGULAR, 3/16"	1	F	9	42	
SOCKET, SOCKET WRENCH, 1/4" DR, 6 PT, REGULAR, 5/32"	1	F	9	43	
SOCKET, SOCKET WRENCH, 1/4" DR, 6 PT, REGULAR, 1/8"	1	F	9	44	
SOCKET, SOCKET WRENCH, 1/4" DR, 6 PT, REGULAR, 9MM	1	F	9	45	
SOCKET, SOCKET WRENCH, 1/4" DR, 6 PT, REGULAR, 8MM	1	F	9	46	
SOCKET, SOCKET WRENCH, 1/4" DR, 6 PT, REGULAR, 7MM	1	F	9	47	
SOCKET, SOCKET WRENCH, 1/4" DR, 6 PT, REGULAR, 6MM	1	F	9	48	
SOCKET, SOCKET WRENCH, 1/4" DR, 6 PT, REGULAR, 5.5MM	1	F	9	49	
SOCKET, SOCKET WRENCH, 1/4" DR, 6 PT, REGULAR, 5MM	1	F	9	50	
SOCKET, SOCKET WRENCH, 1/4" DR, 6 PT, REGULAR, 4.5MM	1	F	9	51	
SOCKET, SOCKET WRENCH, 1/4" DR, 6 PT, REGULAR, 4MM	1	F	9	52	
SOCKET, SOCKET WRENCH, 1/4" DR, 6 PT, REGULAR, 10MM	1	F	9	53	
SOCKET, SOCKET WRENCH, 1/4" DR, 6 PT, REGULAR, 11MM	1	F	9	54	
SOCKET, SOCKET WRENCH, 1/4" DR, 6 PT, REGULAR, 12MM	1	F	9	55	
SOCKET, SOCKET WRENCH, 1/4" DR, 6 PT, REGULAR, 13MM	1	F	9	56	
SOCKET, SOCKET WRENCH, 1/4" DR, 6 PT, REGULAR, 14MM	1	F	9	57	
SOCKET, SOCKET WRENCH, 1/4" DR, 6 PT, REGULAR, 15MM	1	F	9	58	
SOCKET, SOCKET WRENCH, 1/2" DR, 12 PT, REGULAR, 25/32"	1	F	9	59	
SOCKET, SOCKET WRENCH, 1/2" DR, 6 PT, REGULAR, 24MM	1	F	9	60	
SOCKET, SOCKET WRENCH, 1/2" DR, 6 PT, REGULAR, 25MM	1	F	9	61	
SOCKET, SOCKET WRENCH, 1/2" DR, 6 PT, REGULAR, 26MM	1	F	9	62	
SOCKET, SOCKET WRENCH, 1/2" DR, 6 PT, REGULAR, 27MM	1	F	9	63	
SOCKET, SOCKET WRENCH, 1/2" DR, 6 PT, REGULAR, 28MM	1	F	9	64	
SOCKET, SOCKET WRENCH, 1/2" DR, 6 PT, REGULAR, 29MM	1	F	9	65	
SOCKET, SOCKET WRENCH, 1/2" DR, 6 PT, REGULAR, 30MM	1	F	9	66	
SOCKET, SOCKET WRENCH, 1/2" DR, 6 PT, REGULAR, 32MM	1	F	9	67	
SOCKET, SOCKET WRENCH, 1/2" DR, 6 PT, REGULAR, 36MM	1	F	9	68	
EXTENSION, 1/2" DR, 10" LONG	1	F	9	69	
SOCKET, SOCKET WRENCH, 1/2" DR, 12 PT, REGULAR, 21/32"	1	F	9	70	
SOCKET, SOCKET WRENCH, 1/2" DR, 6 PT, REGULAR, 23MM	1	F	9	71	
SOCKET, SOCKET WRENCH, 1/2" DR, 6 PT, REGULAR, 22MM	1	F	9	72	
SOCKET, SOCKET WRENCH, 1/2" DR, 6 PT, REGULAR, 21MM	1	F	9	73	

TM 9-4910-783-13&P

SATS FMM1 TOOL INVENTORY LIST

0059 00

NOMENCLATURE	QTY	RACK	DRAWER	LOCATION	INVENTORY AMOUNT
SOCKET, SOCKET WRENCH, 1/2" DR, 6 PT, REGULAR, 19MM	1	F	9	74	
SOCKET, SOCKET WRENCH, 1/2" DR, 6 PT, REGULAR, 18MM	1	F	9	75	
SOCKET, SOCKET WRENCH, 1/2" DR, 6 PT, REGULAR, 17MM	1	F	9	76	
SOCKET, SOCKET WRENCH, 1/2" DR, 6 PT, REGULAR, 16MM	1	F	9	77	
SOCKET, SOCKET WRENCH, 1/2" DR, 6 PT, REGULAR, 15MM	1	F	9	78	
SOCKET, SOCKET WRENCH, 1/2" DR, 6 PT, REGULAR, 14MM	1	F	9	79	
SOCKET, SOCKET WRENCH, 1/2" DR, 6 PT, REGULAR, 13MM	1	F	9	80	
SOCKET, SOCKET WRENCH, 1/2" DR, 6 PT, REGULAR, 12MM	1	F	9	81	
SOCKET, SOCKET WRENCH, 1/2" DR, 6 PT, REGULAR, 11MM	1	F	9	82	
SOCKET, SOCKET WRENCH, 1/2" DR, 12 PT, REGULAR, 19/32"	1	F	9	83	
SOCKET, SOCKET WRENCH, 1/2" DR, 6 PT, REGULAR, 9MM	1	F	9	84	
SOCKET, SOCKET WRENCH, 1/2" DR, 6 PT, REGULAR, 10MM	1	F	9	85	
SOCKET, SOCKET WRENCH, 1/2" DR, 12 PT, DEEP, 19MM	1	F	9	86	
SOCKET, SOCKET WRENCH, 1/2" DR, 12 PT, DEEP, 18MM	1	F	9	87	
SOCKET, SOCKET WRENCH, 1/2" DR, 12 PT, DEEP, 17MM	1	F	9	88	
SOCKET, SOCKET WRENCH, 1/2" DR, 12 PT, DEEP, 16MM	1	F	9	89	
SOCKET, SOCKET WRENCH, 1/2" DR, 12 PT, DEEP, 15MM	1	F	9	90	
SOCKET, SOCKET WRENCH, 1/2" DR, 12 PT, DEEP, 14MM	1	F	9	91	
SOCKET, SOCKET WRENCH, 1/2" DR, 12 PT, DEEP, 13MM	1	F	9	92	
SOCKET, SOCKET WRENCH, 1/2" DR, 12 PT, DEEP, 12MM	1	F	9	93	
SOCKET, SOCKET WRENCH, 1/2" DR, 12 PT, DEEP, 11MM	1	F	9	94	
SOCKET, SOCKET WRENCH, 1/2" DR, 12 PT, DEEP, 10MM	1	F	9	95	
EXTENSION, 1/2" DR, 5" LONG	1	F	9	96	
EXTENSION, 1/2" DR, 3" LONG	1	F	9	97	
SOCKET, SOCKET WRENCH, 1/2" DR, 12 PT, DEEP, 20MM	1	F	9	98	
SOCKET, SOCKET WRENCH, 1/2" DR, 12 PT, DEEP, 21MM	1	F	9	99	
SOCKET, SOCKET WRENCH, 1/2" DR, 12 PT, DEEP, 22MM	1	F	9	100	
SOCKET, SOCKET WRENCH, 1/2" DR, 12 PT, DEEP, 23MM	1	F	9	101	
SOCKET, SOCKET WRENCH, 1/2" DR, 12 PT, DEEP, 24MM	1	F	9	102	
SOCKET, SOCKET WRENCH, 1/2" DR, 12 PT, DEEP, 25MM	1	F	9	103	
SOCKET, SOCKET WRENCH, 1/2" DR, 12 PT, DEEP, 26MM	1	F	9	104	
SOCKET, SOCKET WRENCH, 1/2" DR, 12 PT, DEEP, 27MM	1	F	9	105	
SOCKET, SOCKET WRENCH, 1/2" DR, 12 PT, DEEP, 28MM	1	F	9	106	
SOCKET, SOCKET WRENCH, 1/2" DR, 12 PT, DEEP, 29MM	1	F	9	107	
SOCKET, SOCKET WRENCH, 1/2" DR, 12 PT, DEEP, 30MM	1	F	9	108	
SOCKET, SOCKET WRENCH, 1/2" DR, 12 PT, DEEP, 32MM	1	F	9	109	

TM 9-4910-783-13&P

F, 10

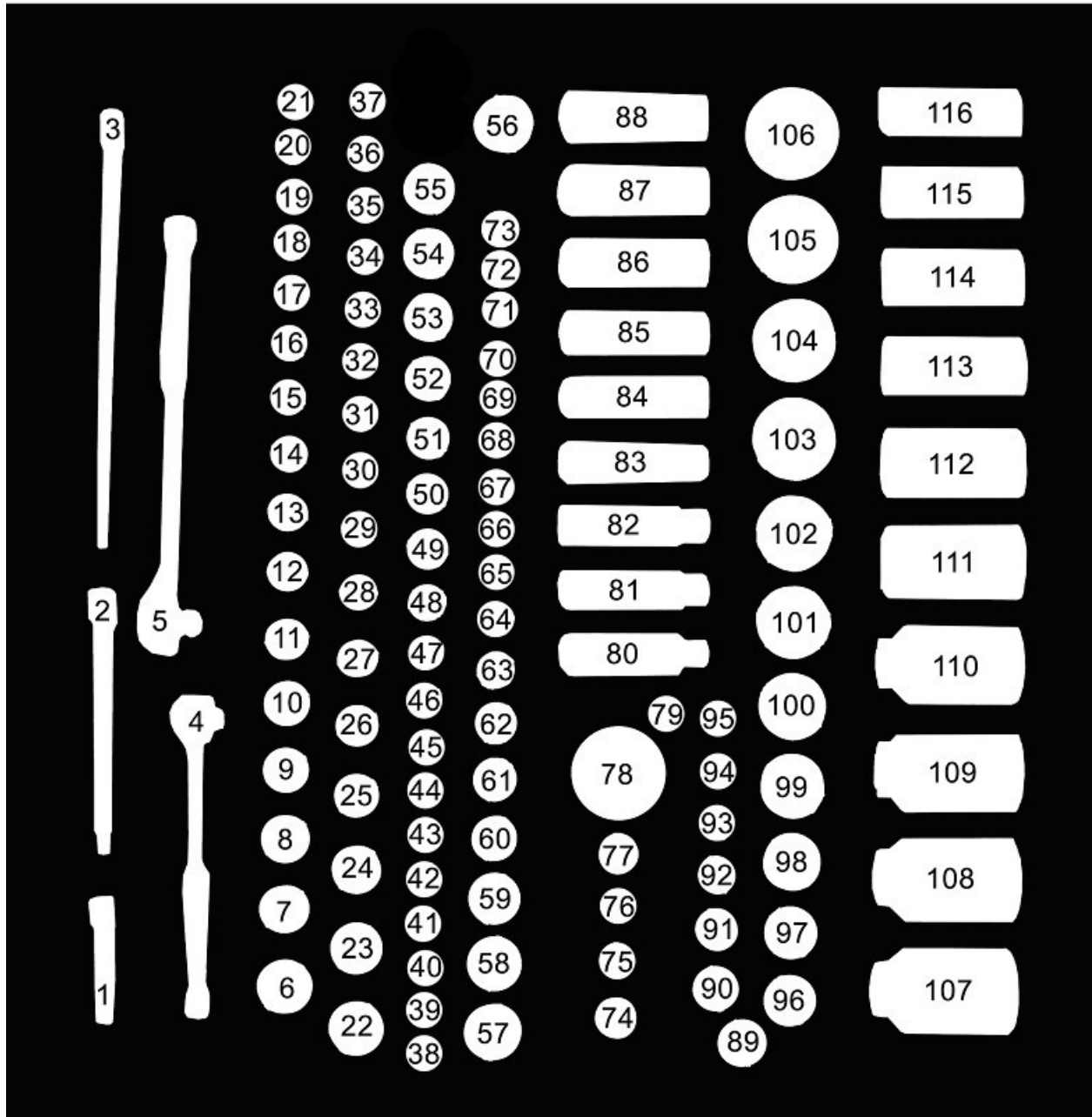

TM 9-4910-783-13&P

SATS FMM1 TOOL INVENTORY LIST

0059 00

INVENTORY

NOMENCLATURE	QTY	RACK	DRAWER	LOCATION	AMOUNT
EXTENSION, 3/8" DR, 3" LONG	1	F	10	1	
EXTENSION, 3/8" DR, 6" LONG	1	F	10	2	
EXTENSION, 3/8" DR, 9.5" LONG	1	F	10	3	
HANDLE, RATCHET, 3/8" DR, 6" LONG	1	F	10	4	
HANDLE, RATCHET, 1/2" DR, 10"LONG	1	F	10	5	
SOCKET, SOCKET WRENCH, 3/8" DR, 6 PT, DEEP, 26MM	1	F	10	6	
SOCKET, SOCKET WRENCH, 3/8" DR, 6 PT, DEEP, 23MM	1	F	10	7	
SOCKET, SOCKET WRENCH, 3/8" DR, 6 PT, DEEP, 22MM	1	F	10	8	
SOCKET, SOCKET WRENCH, 3/8" DR, 6 PT, DEEP, 21MM	1	F	10	9	
SOCKET, SOCKET WRENCH, 3/8" DR, 6 PT, DEEP, 20MM	1	F	10	10	
SOCKET, SOCKET WRENCH, 3/8" DR, 6 PT, DEEP, 19MM	1	F	10	11	
SOCKET, SOCKET WRENCH, 3/8" DR, 6 PT, DEEP, 18MM	1	F	10	12	
SOCKET, SOCKET WRENCH, 3/8" DR, 6 PT, DEEP, 17MM	1	F	10	13	
SOCKET, SOCKET WRENCH, 3/8" DR, 6 PT, DEEP, 16MM	1	F	10	14	
SOCKET, SOCKET WRENCH, 3/8" DR, 6 PT, DEEP, 15MM	1	F	10	15	
SOCKET, SOCKET WRENCH, 3/8" DR, 6 PT, DEEP, 14MM	1	F	10	16	
SOCKET, SOCKET WRENCH, 3/8" DR, 6 PT, DEEP, 13MM	1	F	10	17	
SOCKET, SOCKET WRENCH, 3/8" DR, 6 PT, DEEP, 12MM	1	F	10	18	
SOCKET, SOCKET WRENCH, 3/8" DR, 6 PT, DEEP, 11MM	1	F	10	19	
SOCKET, SOCKET WRENCH, 3/8" DR, 6 PT, DEEP, 10MM	1	F	10	20	
SOCKET, SOCKET WRENCH, 3/8" DR, 6 PT, DEEP, 9MM	1	F	10	21	
SOCKET, SOCKET WRENCH, 3/8" DR, 6 PT, DEEP, 1"	1	F	10	22	
SOCKET, SOCKET WRENCH, 3/8" DR, 6 PT, DEEP, 15/16"	1	F	10	23	
SOCKET, SOCKET WRENCH, 3/8" DR, 6 PT, DEEP, 7/8"	1	F	10	24	
SOCKET, SOCKET WRENCH, 3/8" DR, 6 PT, DEEP, 13/16"	1	F	10	25	
SOCKET, SOCKET WRENCH, 3/8" DR, 6 PT, DEEP, 3/4"	1	F	10	26	
SOCKET, SOCKET WRENCH, 3/8" DR, 6 PT, DEEP, 11/16"	1	F	10	27	
SOCKET, SOCKET WRENCH, 3/8" DR, 6 PT, DEEP, 5/8"	1	F	10	28	
SOCKET, SOCKET WRENCH, 3/8" DR, 6 PT, DEEP, 9/16"	1	F	10	29	
SOCKET, SOCKET WRENCH, 3/8" DR, 6 PT, DEEP, 1/2"	1	F	10	30	
SOCKET, SOCKET WRENCH, 3/8" DR, 6 PT, DEEP, 7/16"	1	F	10	31	
SOCKET, SOCKET WRENCH, 3/8" DR, 6 PT, DEEP, 3/8"	1	F	10	32	
SOCKET, SOCKET WRENCH, 3/8" DR, 6 PT, DEEP, 5/16"	1	F	10	33	
SOCKET, SOCKET WRENCH, 3/8" DR, 6 PT, DEEP, 1/4"	1	F	10	34	
SOCKET, SOCKET WRENCH, 3/8" DR, 6 PT, DEEP, 6MM	1	F	10	35	
SOCKET, SOCKET WRENCH, 3/8" DR, 6 PT, DEEP, 7MM	1	F	10	36	

TM 9-4910-783-13&P

SATS FMM1 TOOL INVENTORY LIST

0059 00

NOMENCLATURE					INVENTORY
	QTY	RACK	DRAWER	LOCATION	AMOUNT
SOCKET, SOCKET WRENCH, 3/8" DR, 6 PT, DEEP, 8MM	1	F	10	37	
SOCKET, SOCKET WRENCH, 3/8" DR, 6 PT, REGULAR, 6MM	1	F	10	38	
SOCKET, SOCKET WRENCH, 3/8" DR, 6 PT, REGULAR, 7MM	1	F	10	39	
SOCKET, SOCKET WRENCH, 3/8" DR, 6 PT, REGULAR, 8MM	1	F	10	40	
SOCKET, SOCKET WRENCH, 3/8" DR, 6 PT, REGULAR, 9MM	1	F	10	41	
SOCKET, SOCKET WRENCH, 3/8" DR, 6 PT, REGULAR, 10MM	1	F	10	42	
SOCKET, SOCKET WRENCH, 3/8" DR, 6 PT, REGULAR, 11MM	1	F	10	43	
SOCKET, SOCKET WRENCH, 3/8" DR, 6 PT, REGULAR, 12MM	1	F	10	44	
SOCKET, SOCKET WRENCH, 3/8" DR, 6 PT, REGULAR, 13MM	1	F	10	45	
SOCKET, SOCKET WRENCH, 3/8" DR, 6 PT, REGULAR, 14MM	1	F	10	46	
SOCKET, SOCKET WRENCH, 3/8" DR, 6 PT, REGULAR, 15MM	1	F	10	47	
SOCKET, SOCKET WRENCH, 3/8" DR, 6 PT, REGULAR, 16MM	1	F	10	48	
SOCKET, SOCKET WRENCH, 3/8" DR, 6 PT, REGULAR, 17MM	1	F	10	49	
SOCKET, SOCKET WRENCH, 3/8" DR, 6 PT, REGULAR, 18MM	1	F	10	50	
SOCKET, SOCKET WRENCH, 3/8" DR, 6 PT, REGULAR, 19MM	1	F	10	51	
SOCKET, SOCKET WRENCH, 3/8" DR, 6 PT, REGULAR, 20MM	1	F	10	52	
SOCKET, SOCKET WRENCH, 3/8" DR, 6 PT, REGULAR, 21MM	1	F	10	53	
SOCKET, SOCKET WRENCH, 3/8" DR, 6 PT, REGULAR, 22MM	1	F	10	54	
SOCKET, SOCKET WRENCH, 3/8" DR, 6 PT, REGULAR, 23MM	1	F	10	55	
SOCKET, SOCKET WRENCH, 3/8" DR, 6 PT, REGULAR, 26MM	1	F	10	56	
SOCKET, SOCKET WRENCH, 3/8" DR, 6 PT, REGULAR, 1"	1	F	10	57	
SOCKET, SOCKET WRENCH, 3/8" DR, 6 PT, REGULAR, 15/16"	1	F	10	58	
SOCKET, SOCKET WRENCH, 3/8" DR, 6 PT, REGULAR, 7/8"	1	F	10	59	
SOCKET, SOCKET WRENCH, 3/8" DR, 6 PT, REGULAR, 13/16"	1	F	10	60	
SOCKET, SOCKET WRENCH, 3/8" DR, 6 PT, REGULAR, 3/4"	1	F	10	61	
SOCKET, SOCKET WRENCH, 3/8" DR, 6 PT, REGULAR, 11/16"	1	F	10	62	
SOCKET, SOCKET WRENCH, 3/8" DR, 6 PT, REGULAR, 5/8"	1	F	10	63	
SOCKET, SOCKET WRENCH, 3/8" DR, 6 PT, REGULAR, 9/16"	1	F	10	64	
SOCKET, SOCKET WRENCH, 3/8" DR, 6 PT, REGULAR, 1/2"	1	F	10	65	
SOCKET, SOCKET WRENCH, 3/8" DR, 6 PT, REGULAR, 7/16"	1	F	10	66	
SOCKET, SOCKET WRENCH, 3/8" DR, 6 PT, REGULAR, 3/8"	1	F	10	67	
SOCKET, SOCKET WRENCH, 3/8" DR, 6 PT, REGULAR, 5/16"	1	F	10	68	
SOCKET, SOCKET WRENCH, 3/8" DR, 6 PT, REGULAR, 1/4"	1	F	10	69	
ADAPTER, SOCKET WRENCH DRIVE, 1/4" MALE - 3/8" FEMALE	1	F	10	70	
ADAPTER, SOCKET WRENCH DRIVE, 1/2" MALE - 3/8" FEMALE	1	F	10	71	
UNIVERSAL, 3/8"	1	F	10	72	
JOINT, UNIVERSAL, 3/8" DR	1	F	10	73	

TM 9-4910-783-13&P

SATS FMM1 TOOL INVENTORY LIST

0059 00

NOMENCLATURE	QTY	RACK	DRAWER	LOCATION	INVENTORY AMOUNT
ADAPTER, SOCKET WRENCH DRIVE, 3/4" MALE - 1/2" FEMALE	1	F	10	74	
ADAPTER, SOCKET WRENCH DRIVE, 3/8" MALE - 1/2" FEMALE	1	F	10	75	
ADAPTER, SOCKET WRENCH DRIVE, 1/2" FEMALE - 1/2" MALE	1	F	10	76	
JOINT, UNIVERSAL, 1/2" DR	1	F	10	77	
STUD REMOVER, 5/16" - 3/4" CAPACITY	1	F	10	78	
SOCKET, SOCKET WRENCH, 1/2" DR, 6 PT, REGULAR, 3/8"	1	F	10	79	
SOCKET, SOCKET WRENCH, 1/2" DR, 6 PT, DEEP, 3/8"	1	F	10	80	
SOCKET, SOCKET WRENCH, 1/2" DR, 6 PT, DEEP, 7/16"	1	F	10	81	
SOCKET, SOCKET WRENCH, 1/2" DR, 6 PT, DEEP, 1/2"	1	F	10	82	
SOCKET, SOCKET WRENCH, 1/2" DR, 6 PT, DEEP, 9/16"	1	F	10	83	
SOCKET, SOCKET WRENCH, 1/2" DR, 6 PT, DEEP, 5/8"	1	F	10	84	
SOCKET, SOCKET WRENCH, 1/2" DR, 6 PT, DEEP, 11/16"	1	F	10	85	
SOCKET, SOCKET WRENCH, 1/2" DR, 6 PT, DEEP, 3/4"	1	F	10	86	
SOCKET, SOCKET WRENCH, 1/2" DR, 6 PT, DEEP, 13/16"	1	F	10	87	
SOCKET, SOCKET WRENCH, 1/2" DR, 6 PT, DEEP, 7/8"	1	F	10	88	
SOCKET, SOCKET WRENCH, 1/2" DR, 6 PT, REGULAR, 13/16"	1	F	10	89	
SOCKET, SOCKET WRENCH, 1/2" DR, 6 PT, REGULAR, 3/4"	1	F	10	90	
SOCKET, SOCKET WRENCH, 1/2" DR, 6 PT, REGULAR, 11/16"	1	F	10	91	
SOCKET, SOCKET WRENCH, 1/2" DR, 6 PT, REGULAR, 5/8"	1	F	10	92	
SOCKET, SOCKET WRENCH, 1/2" DR, 6 PT, REGULAR, 9/16"	1	F	10	93	
SOCKET, SOCKET WRENCH, 1/2" DR, 6 PT, REGULAR, 1/2"	1	F	10	94	
SOCKET, SOCKET WRENCH, 1/2" DR, 6 PT, REGULAR, 7/16"	1	F	10	95	
SOCKET, SOCKET WRENCH, 1/2" DR, 6 PT, REGULAR, 7/8"	1	F	10	96	
SOCKET, SOCKET WRENCH, 1/2" DR, 6 PT, REGULAR, 15/16"	1	F	10	97	
SOCKET, SOCKET WRENCH, 1/2" DR, 6 PT, REGULAR, 1"	1	F	10	98	
SOCKET, SOCKET WRENCH, 1/2" DR, 6 PT, REGULAR, 1-1/16"	1	F	10	99	
SOCKET, SOCKET WRENCH, 1/2" DR, 6 PT, REGULAR, 1-1/8"	1	F	10	100	
SOCKET, SOCKET WRENCH, 1/2" DR, 6 PT, REGULAR, 1-3/16"	1	F	10	101	
SOCKET, SOCKET WRENCH, 1/2" DR, 6 PT, REGULAR, 1-1/4"	1	F	10	102	
SOCKET, SOCKET WRENCH, 1/2" DR, 6 PT, REGULAR, 1-5/16"	1	F	10	103	
SOCKET, SOCKET WRENCH, 1/2" DR, 6 PT, REGULAR, 1-3/8"	1	F	10	104	
SOCKET, SOCKET WRENCH, 1/2" DR, 6 PT, REGULAR, 1-7/16"	1	F	10	105	
SOCKET, SOCKET WRENCH, 1/2" DR, 6 PT, REGULAR, 1-1/2"	1	F	10	106	
SOCKET, SOCKET WRENCH, 1/2" DR, 6 PT, DEEP, 1-1/2"	1	F	10	107	
SOCKET, SOCKET WRENCH, 1/2" DR, 6 PT, DEEP, 1-7/16"	1	F	10	108	
SOCKET, SOCKET WRENCH, 1/2" DR, 6 PT, DEEP, 1-3/8"	1	F	10	109	
SOCKET, SOCKET WRENCH, 1/2" DR, 6 PT, DEEP, 1-5/16"	1	F	10	110	

TM 9-4910-783-13&P

SATS FMM1 TOOL INVENTORY LIST

0059 00

NOMENCLATURE	INVENTORY				
	QTY	RACK	DRAWER	LOCATION	AMOUNT
SOCKET, SOCKET WRENCH, 1/2" DR, 6 PT, DEEP, 1-1/4"	1	F	10	111	
SOCKET, SOCKET WRENCH, 1/2" DR, 6 PT, DEEP, 1-3/16"	1	F	10	112	
SOCKET, SOCKET WRENCH, 1/2" DR, 6 PT, DEEP, 1-1/8"	1	F	10	113	
SOCKET, SOCKET WRENCH, 1/2" DR, 6 PT, DEEP, 1-1/16"	1	F	10	114	
SOCKET, SOCKET WRENCH, 1/2" DR, 6 PT, DEEP, 1"	1	F	10	115	
SOCKET, SOCKET WRENCH, 1/2" DR, 6 PT, DEEP, 15/16"	1	F	10	116	

TM 9-4910-783-13&P

SATS FMM1 TOOL INVENTORY LIST

0059 00

THIS PAGE INTENTIONALLY LEFT BLANK

TM 9-4910-783-13&P

SATS FMM1 TOOL INVENTORY LIST

0059 00

F, 11

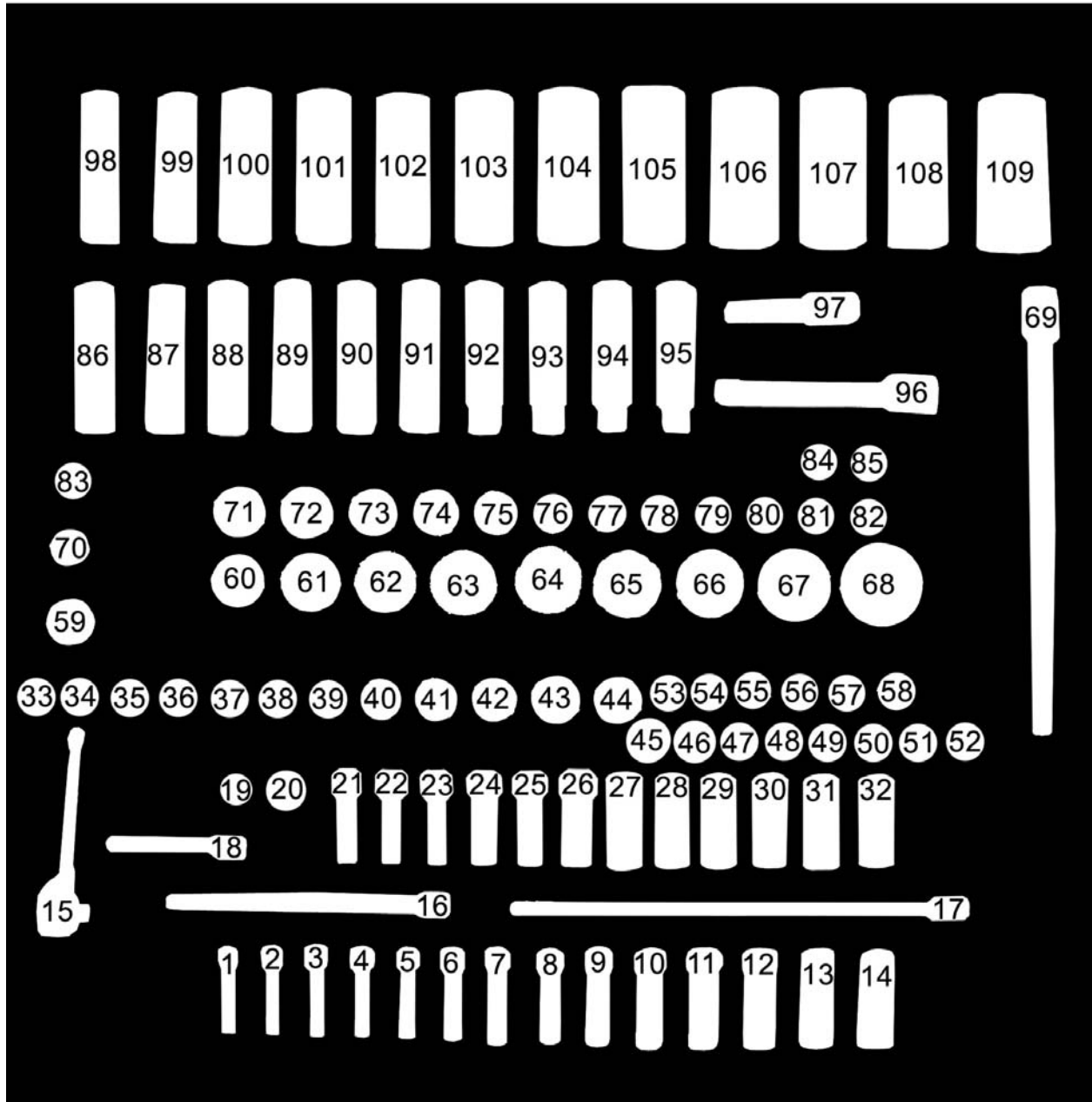

TM 9-4910-783-13&P

SATS FMM1 TOOL INVENTORY LIST

0059 00

INVENTORY

NOMENCLATURE	QTY	RACK	DRAWER	LOCATION	AMOUNT
SOCKET, SOCKET WRENCH, 1/4" DR, 6 PT, DEEP, 4MM	1	F	11	1	
SOCKET, SOCKET WRENCH, 1/4" DR, 6 PT, DEEP, 4.5MM	1	F	11	2	
SOCKET, SOCKET WRENCH, 1/4" DR, 6 PT, DEEP, 5MM	1	F	11	3	
SOCKET, SOCKET WRENCH, 1/4" DR, 6 PT, DEEP, 5.5MM	1	F	11	4	
SOCKET, SOCKET WRENCH, 1/4" DR, 6 PT, DEEP, 6MM	1	F	11	5	
SOCKET, SOCKET WRENCH, 1/4" DR, 6 PT, DEEP, 7MM	1	F	11	6	
SOCKET, SOCKET WRENCH, 1/4" DR, 6 PT, DEEP, 8MM	1	F	11	7	
SOCKET, SOCKET WRENCH, 1/4" DR, 6 PT, DEEP, 9MM	1	F	11	8	
SOCKET, SOCKET WRENCH, 1/4" DR, 6 PT, DEEP, 10MM	1	F	11	9	
SOCKET, SOCKET WRENCH, 1/4" DR, 6 PT, DEEP, 11MM	1	F	11	10	
SOCKET, SOCKET WRENCH, 1/4" DR, 6 PT, DEEP, 12MM	1	F	11	11	
SOCKET, SOCKET WRENCH, 1/4" DR, 6 PT, DEEP, 13MM	1	F	11	12	
SOCKET, SOCKET WRENCH, 1/4" DR, 6 PT, DEEP, 14MM	1	F	11	13	
SOCKET, SOCKET WRENCH, 1/4" DR, 6 PT, DEEP, 15MM	1	F	11	14	
HANDLE, REVERSIBLE RATCHET, SOCKET WRENCH, 1/4" DR, 4.375" LONG	1	F	11	15	
EXTENSION, 1/4" DR, 6" LONG	1	F	11	16	
EXTENSION, 1/4" DR, 10" LONG	1	F	11	17	
EXTENSION, 1/4" DR, 3" LONG	1	F	11	18	
ADAPTER, SOCKET WRENCH DRIVE, 3/8" MALE - 1/4" FEMALE	1	F	11	19	
JOINT, UNIVERSAL, 1/4" DR	1	F	11	20	
SOCKET, SOCKET WRENCH, 1/4" DR, 6 PT, DEEP, 1/8"	1	F	11	21	
SOCKET, SOCKET WRENCH, 1/4" DR, 6 PT, DEEP, 5/32"	1	F	11	22	
SOCKET, SOCKET WRENCH, 1/4" DR, 6 PT, DEEP, 3/16"	1	F	11	23	
SOCKET, SOCKET WRENCH, 1/4" DR, 6 PT, DEEP, 7/32"	1	F	11	24	
SOCKET, SOCKET WRENCH, 1/4" DR, 6 PT, DEEP, 1/4"	1	F	11	25	
SOCKET, SOCKET WRENCH, 1/4" DR, 6 PT, DEEP, 9/32"	1	F	11	26	
SOCKET, SOCKET WRENCH, 1/4" DR, 6 PT, DEEP, 5/16"	1	F	11	27	
SOCKET, SOCKET WRENCH, 1/4" DR, 6 PT, DEEP, 11/32"	1	F	11	28	
SOCKET, SOCKET WRENCH, 1/4" DR, 6 PT, DEEP, 3/8"	1	F	11	29	
SOCKET, SOCKET WRENCH, 1/4" DR, 6 PT, DEEP, 7/16"	1	F	11	30	
SOCKET, SOCKET WRENCH, 1/4" DR, 6 PT, DEEP, 1/2"	1	F	11	31	
SOCKET, SOCKET WRENCH, 1/4" DR, 6 PT, DEEP, 9/16"	1	F	11	32	
SOCKET, SOCKET WRENCH, 1/4" DR, 6 PT, REGULAR, 9/16"	1	F	11	33	
SOCKET, SOCKET WRENCH, 1/4" DR, 6 PT, REGULAR, 1/2"	1	F	11	34	
SOCKET, SOCKET WRENCH, 1/4" DR, 6 PT, REGULAR, 7/16"	1	F	11	35	
SOCKET, SOCKET WRENCH, 1/4" DR, 6 PT, REGULAR, 3/8"	1	F	11	36	

TM 9-4910-783-13&P

SATS FMM1 TOOL INVENTORY LIST

0059 00

NOMENCLATURE	INVENTORY				AMOUNT
	QTY	RACK	DRAWER	LOCATION	
SOCKET, SOCKET WRENCH, 1/4" DR, 6 PT, REGULAR, 11/32"	1	F	11	37	
SOCKET, SOCKET WRENCH, 1/4" DR, 6 PT, REGULAR, 5/16"	1	F	11	38	
SOCKET, SOCKET WRENCH, 1/4" DR, 6 PT, REGULAR, 9/32"	1	F	11	39	
SOCKET, SOCKET WRENCH, 1/4" DR, 6 PT, REGULAR, 1/4"	1	F	11	40	
SOCKET, SOCKET WRENCH, 1/4" DR, 6 PT, REGULAR, 7/32"	1	F	11	41	
SOCKET, SOCKET WRENCH, 1/4" DR, 6 PT, REGULAR, 3/16"	1	F	11	42	
SOCKET, SOCKET WRENCH, 1/4" DR, 6 PT, REGULAR, 5/32"	1	F	11	43	
SOCKET, SOCKET WRENCH, 1/4" DR, 6 PT, REGULAR, 1/8"	1	F	11	44	
SOCKET, SOCKET WRENCH, 1/4" DR, 6 PT, REGULAR, 9MM	1	F	11	45	
SOCKET, SOCKET WRENCH, 1/4" DR, 6 PT, REGULAR, 8MM	1	F	11	46	
SOCKET, SOCKET WRENCH, 1/4" DR, 6 PT, REGULAR, 7MM	1	F	11	47	
SOCKET, SOCKET WRENCH, 1/4" DR, 6 PT, REGULAR, 6MM	1	F	11	48	
SOCKET, SOCKET WRENCH, 1/4" DR, 6 PT, REGULAR, 5.5MM	1	F	11	49	
SOCKET, SOCKET WRENCH, 1/4" DR, 6 PT, REGULAR, 5MM	1	F	11	50	
SOCKET, SOCKET WRENCH, 1/4" DR, 6 PT, REGULAR, 4.5MM	1	F	11	51	
SOCKET, SOCKET WRENCH, 1/4" DR, 6 PT, REGULAR, 4MM	1	F	11	52	
SOCKET, SOCKET WRENCH, 1/4" DR, 6 PT, REGULAR, 10MM	1	F	11	53	
SOCKET, SOCKET WRENCH, 1/4" DR, 6 PT, REGULAR, 11MM	1	F	11	54	
SOCKET, SOCKET WRENCH, 1/4" DR, 6 PT, REGULAR, 12MM	1	F	11	55	
SOCKET, SOCKET WRENCH, 1/4" DR, 6 PT, REGULAR, 13MM	1	F	11	56	
SOCKET, SOCKET WRENCH, 1/4" DR, 6 PT, REGULAR, 14MM	1	F	11	57	
SOCKET, SOCKET WRENCH, 1/4" DR, 6 PT, REGULAR, 15MM	1	F	11	58	
SOCKET, SOCKET WRENCH, 1/2" DR, 12 PT, REGULAR, 25/32"	1	F	11	59	
SOCKET, SOCKET WRENCH, 1/2" DR, 6 PT, REGULAR, 24MM	1	F	11	60	
SOCKET, SOCKET WRENCH, 1/2" DR, 6 PT, REGULAR, 25MM	1	F	11	61	
SOCKET, SOCKET WRENCH, 1/2" DR, 6 PT, REGULAR, 26MM	1	F	11	62	
SOCKET, SOCKET WRENCH, 1/2" DR, 6 PT, REGULAR, 27MM	1	F	11	63	
SOCKET, SOCKET WRENCH, 1/2" DR, 6 PT, REGULAR, 28MM	1	F	11	64	
SOCKET, SOCKET WRENCH, 1/2" DR, 6 PT, REGULAR, 29MM	1	F	11	65	
SOCKET, SOCKET WRENCH, 1/2" DR, 6 PT, REGULAR, 30MM	1	F	11	66	
SOCKET, SOCKET WRENCH, 1/2" DR, 6 PT, REGULAR, 32MM	1	F	11	67	
SOCKET, SOCKET WRENCH, 1/2" DR, 6 PT, REGULAR, 36MM	1	F	11	68	
EXTENSION, 1/2" DR, 10" LONG	1	F	11	69	
SOCKET, SOCKET WRENCH, 1/2" DR, 12 PT, REGULAR, 21/32"	1	F	11	70	
SOCKET, SOCKET WRENCH, 1/2" DR, 6 PT, REGULAR, 23MM	1	F	11	71	
SOCKET, SOCKET WRENCH, 1/2" DR, 6 PT, REGULAR, 22MM	1	F	11	72	
SOCKET, SOCKET WRENCH, 1/2" DR, 6 PT, REGULAR, 21MM	1	F	11	73	

TM 9-4910-783-13&P

SATS FMM1 TOOL INVENTORY LIST

0059 00

NOMENCLATURE					INVENTORY
	QTY	RACK	DRAWER	LOCATION	AMOUNT
SOCKET, SOCKET WRENCH, 1/2" DR, 6 PT, REGULAR, 19MM	1	F	11	74	
SOCKET, SOCKET WRENCH, 1/2" DR, 6 PT, REGULAR, 18MM	1	F	11	75	
SOCKET, SOCKET WRENCH, 1/2" DR, 6 PT, REGULAR, 17MM	1	F	11	76	
SOCKET, SOCKET WRENCH, 1/2" DR, 6 PT, REGULAR, 16MM	1	F	11	77	
SOCKET, SOCKET WRENCH, 1/2" DR, 6 PT, REGULAR, 15MM	1	F	11	78	
SOCKET, SOCKET WRENCH, 1/2" DR, 6 PT, REGULAR, 14MM	1	F	11	79	
SOCKET, SOCKET WRENCH, 1/2" DR, 6 PT, REGULAR, 13MM	1	F	11	80	
SOCKET, SOCKET WRENCH, 1/2" DR, 6 PT, REGULAR, 12MM	1	F	11	81	
SOCKET, SOCKET WRENCH, 1/2" DR, 6 PT, REGULAR, 11MM	1	F	11	82	
SOCKET, SOCKET WRENCH, 1/2" DR, 12 PT, REGULAR, 19/32"	1	F	11	83	
SOCKET, SOCKET WRENCH, 1/2" DR, 6 PT, REGULAR, 9MM	1	F	11	84	
SOCKET, SOCKET WRENCH, 1/2" DR, 6 PT, REGULAR, 10MM	1	F	11	85	
SOCKET, SOCKET WRENCH, 1/2" DR, 12 PT, DEEP, 19MM	1	F	11	86	
SOCKET, SOCKET WRENCH, 1/2" DR, 12 PT, DEEP, 18MM	1	F	11	87	
SOCKET, SOCKET WRENCH, 1/2" DR, 12 PT, DEEP, 17MM	1	F	11	88	
SOCKET, SOCKET WRENCH, 1/2" DR, 12 PT, DEEP, 16MM	1	F	11	89	
SOCKET, SOCKET WRENCH, 1/2" DR, 12 PT, DEEP, 15MM	1	F	11	90	
SOCKET, SOCKET WRENCH, 1/2" DR, 12 PT, DEEP, 14MM	1	F	11	91	
SOCKET, SOCKET WRENCH, 1/2" DR, 12 PT, DEEP, 13MM	1	F	11	92	
SOCKET, SOCKET WRENCH, 1/2" DR, 12 PT, DEEP, 12MM	1	F	11	93	
SOCKET, SOCKET WRENCH, 1/2" DR, 12 PT, DEEP, 11MM	1	F	11	94	
SOCKET, SOCKET WRENCH, 1/2" DR, 12 PT, DEEP, 10MM	1	F	11	95	
EXTENSION, 1/2" DR, 5" LONG	1	F	11	96	
EXTENSION, 1/2" DR, 3" LONG	1	F	11	97	
SOCKET, SOCKET WRENCH, 1/2" DR, 12 PT, DEEP, 20MM	1	F	11	98	
SOCKET, SOCKET WRENCH, 1/2" DR, 12 PT, DEEP, 21MM	1	F	11	99	
SOCKET, SOCKET WRENCH, 1/2" DR, 12 PT, DEEP, 22MM	1	F	11	100	
SOCKET, SOCKET WRENCH, 1/2" DR, 12 PT, DEEP, 23MM	1	F	11	101	
SOCKET, SOCKET WRENCH, 1/2" DR, 12 PT, DEEP, 24MM	1	F	11	102	
SOCKET, SOCKET WRENCH, 1/2" DR, 12 PT, DEEP, 25MM	1	F	11	103	
SOCKET, SOCKET WRENCH, 1/2" DR, 12 PT, DEEP, 26MM	1	F	11	104	
SOCKET, SOCKET WRENCH, 1/2" DR, 12 PT, DEEP, 27MM	1	F	11	105	
SOCKET, SOCKET WRENCH, 1/2" DR, 12 PT, DEEP, 28MM	1	F	11	106	
SOCKET, SOCKET WRENCH, 1/2" DR, 12 PT, DEEP, 29MM	1	F	11	107	
SOCKET, SOCKET WRENCH, 1/2" DR, 12 PT, DEEP, 30MM	1	F	11	108	
SOCKET, SOCKET WRENCH, 1/2" DR, 12 PT, DEEP, 32MM	1	F	11	109	

TM 9-4910-783-13&P

SATS FMM1 TOOL INVENTORY LIST

0059 00

INVENTORY

NOMENCLATURE	QTY	RACK	DRAWER	LOCATION	AMOUNT
TOOL KIT, HOSE END CRIMPING	1	G	3	1	
WRENCH, ADJUSTABLE, 18"	1	G	3	2	
WRENCH, ADJUSTABLE, 18"	1	G	3	3	
DRESSER, ABRASIVE WHEEL	1	G	3	4	
WHEEL, ABRASIVE, 90 GRIT (PROTOTYPE ONLY)	1	G	3	5	
WHEEL, ABRASIVE, 36 GRIT (PROTOTYPE ONLY)	1	G	3	6	

G, 3

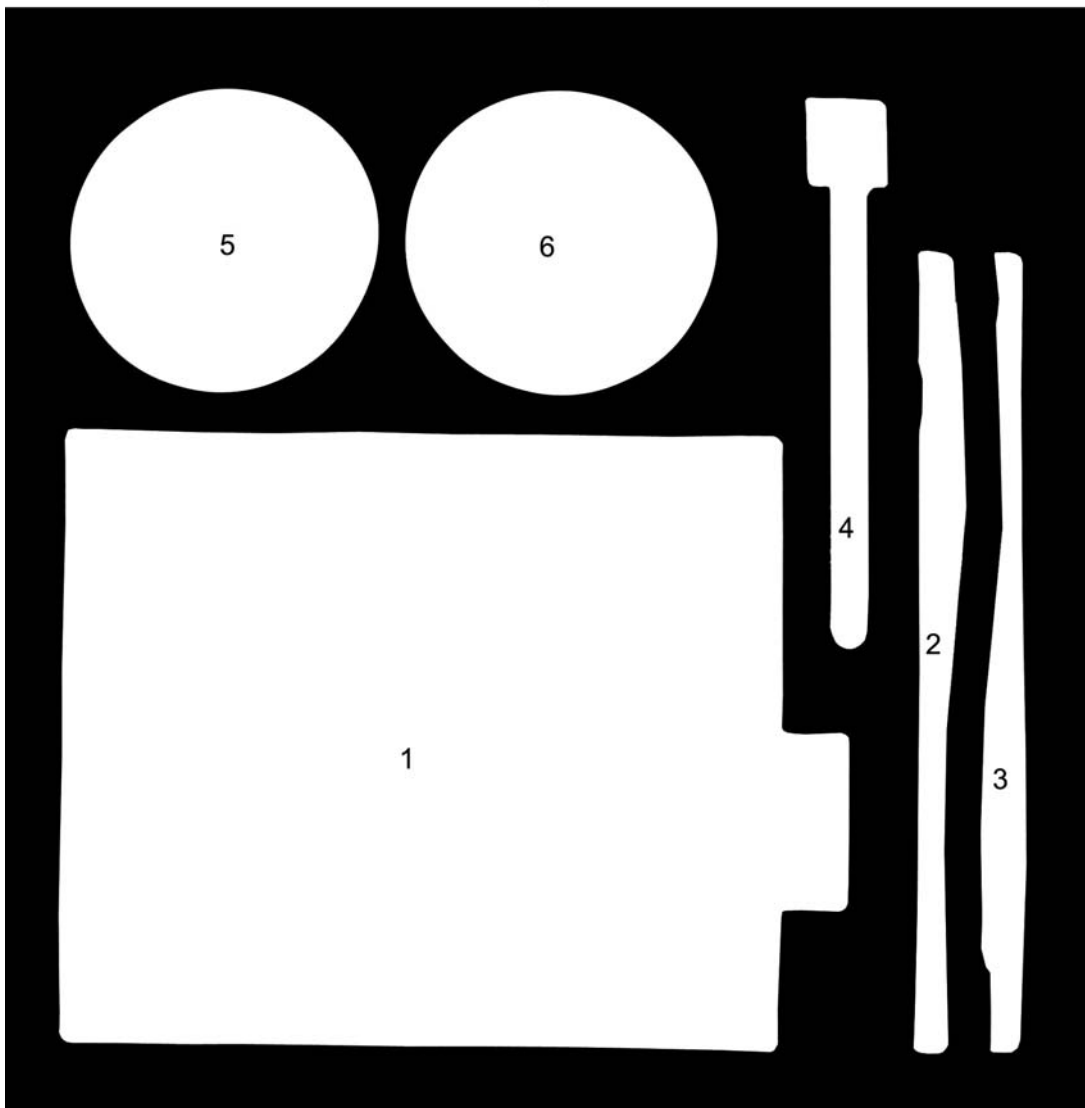

TM 9-4910-783-13&P

SATS FMM1 TOOL INVENTORY LIST

0059 00

INVENTORY

NOMENCLATURE	QTY	RACK	DRAWER	LOCATION	AMOUNT
DRILL-DRIVER, BATTERY OPERATED, RECHARGEABLE, RIGHT ANGLE, 3/8"	1	G	4	3	
DRILL, ELECTRIC, PORTABLE, 1/2"	1	G	4	2	
DRILL, HANDLE	1	G	4	1	

G, 4

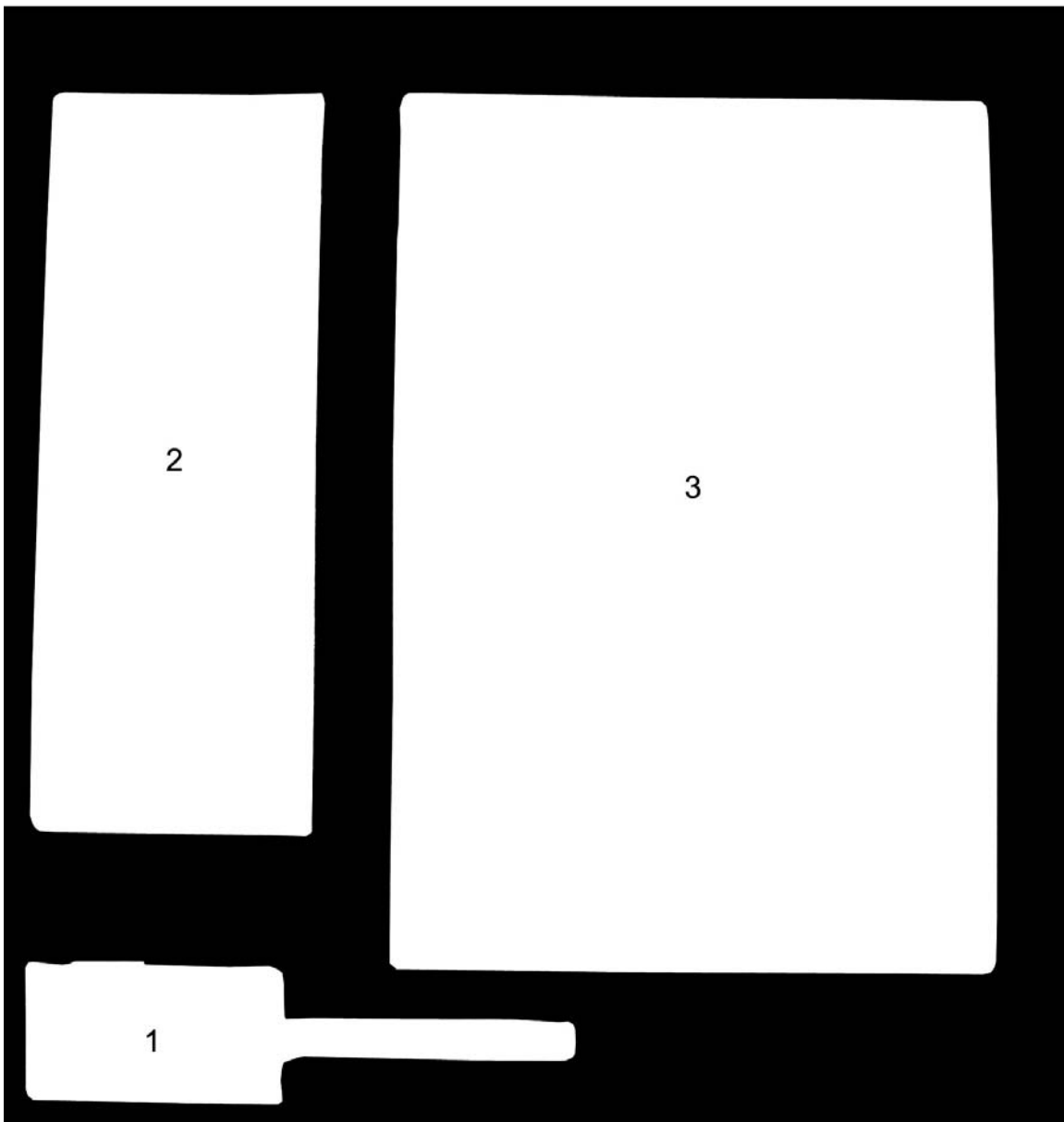

TM 9-4910-783-13&P

SATS FMM1 TOOL INVENTORY LIST

0059 00

INVENTORY

NOMENCLATURE	QTY	RACK	DRAWER	LOCATION	AMOUNT
DRILL, ELECTRIC, PORTABLE, 3/8"	1	G	5	1	
DRILL, ELECTRIC, PORTABLE, 1/2"	1	G	5	2	
DRILL-DRIVER, BATTERY OPERATED, RECHARGEABLE	1	G	5	3	

G, 5

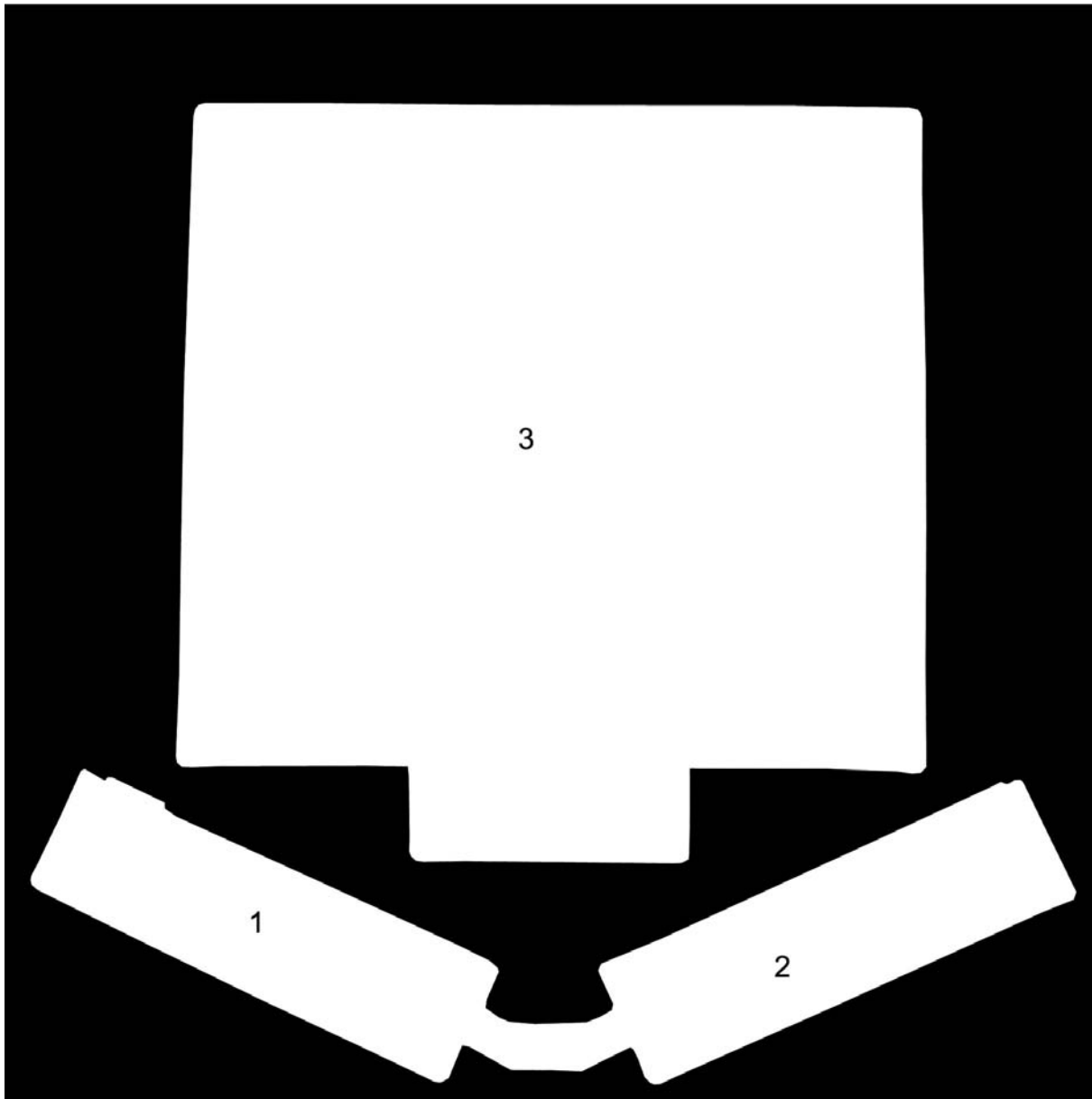

TM 9-4910-783-13&P

SATS FMM1 TOOL INVENTORY LIST

0059 00

INVENTORY

NOMENCLATURE	QTY	RACK	DRAWER	LOCATION	AMOUNT
DIE SET, METAL STAMPING, HAND, ALPHABETIC	1	G	6	1	
WISE, PIPE	1	G	6	2	
PLIERS, MULTIPLE POSITION	1	G	6	3	
TOOL KIT, HOSE END CRIMPING	1	G	6	4	
WRENCH, ADJUSTABLE, 10"	1	G	6	5	
DIE SET, METAL STAMPING, HAND, ALPHABETIC AND NUMERIC	1	G	6	6	
WRENCH, ADJUSTABLE, 10"	1	G	6	7	

G, 6

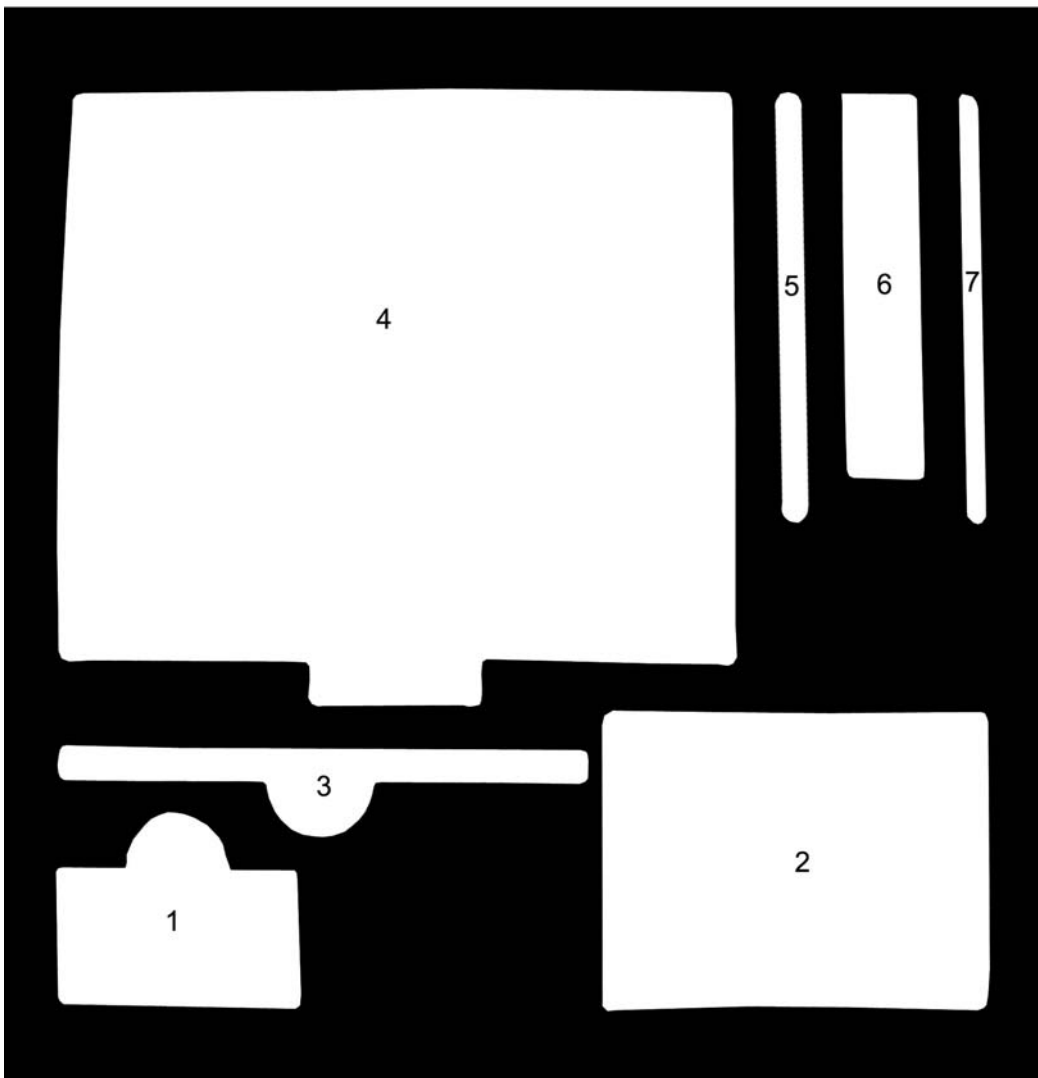

TM 9-4910-783-13&P

G, 7

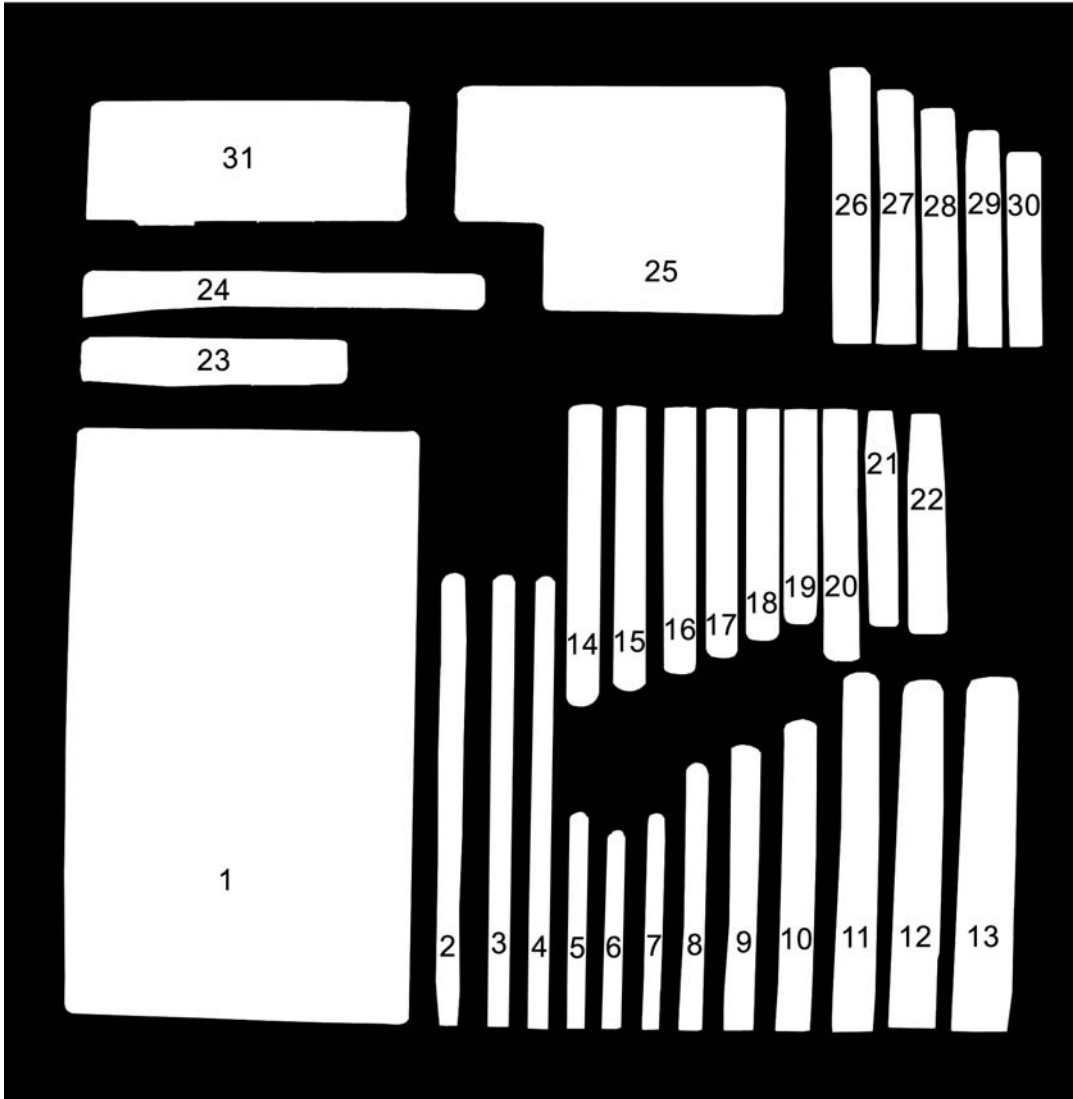

TM 9-4910-783-13&P

SATS FMM1 TOOL INVENTORY LIST

0059 00

INVENTORY

NOMENCLATURE	QTY	RACK	DRAWER	LOCATION	AMOUNT
WRENCH KIT, RATCHET, PNEUMATIC	1	G	7	1	
PUNCH AND CHISEL SET, PUNCH, 1/2" DIA, 1/4" PT	1	G	7	2	
PUNCH AND CHISEL SET, PUNCH, 3/8" DIA, 3/16" PT	1	G	7	3	
PUNCH AND CHISEL SET, PUNCH, 5/16" DIA, 1/8" PT	1	G	7	4	
PUNCH AND CHISEL SET, CHISEL, 3/16" DIA, 1/4"	1	G	7	5	
PUNCH AND CHISEL SET, CHISEL, 1/4" DIA, 5/16"	1	G	7	6	
PUNCH AND CHISEL SET, CHISEL, 5/16" DIA, 3/8"	1	G	7	7	
PUNCH AND CHISEL SET, CHISEL, 7/16" DIA, 1/2"	1	G	7	8	
PUNCH AND CHISEL SET, CHISEL, 1/2" DIA, 5/8"	1	G	7	9	
PUNCH AND CHISEL SET, CHISEL, 5/8" DIA, 3/4"	1	G	7	10	
PUNCH AND CHISEL SET, CHISEL, 3/4" DIA, 7/8"	1	G	7	11	
PUNCH AND CHISEL SET, CHISEL, 7/8" DIA, 1"	1	G	7	12	
PUNCH AND CHISEL SET, CHISEL, 1" DIA, 1 3/16"	1	G	7	13	
PUNCH AND CHISEL SET, PUNCH, 1/2", 1/4" PT	1	G	7	14	
PUNCH AND CHISEL SET, PUNCH, 7/16", 7/32" PT	1	G	7	15	
PUNCH AND CHISEL SET, PUNCH, 3/8", 3/16" PT	1	G	7	16	
PUNCH AND CHISEL SET, PUNCH, 5/16", 5/32" PT	1	G	7	17	
PUNCH AND CHISEL SET, PUNCH, 5/16", 1/8" PT	1	G	7	18	
PUNCH AND CHISEL SET, PUNCH, 1/4", 3/32" PT	1	G	7	19	
PUNCH AND CHISEL SET, PUNCH, 1/2"	1	G	7	20	
PUNCH AND CHISEL SET, PUNCH, 3/8"	1	G	7	21	
PUNCH AND CHISEL SET, PUNCH, 5/16"	1	G	7	22	
HOLDER, PUNCH AND CHISEL	1	G	7	23	
PLIERS, MULTIPLE POSITION, ELECTRICAL CONNECTOR	1	G	7	24	
MULTIMETER	1	G	7	25	
PUNCH AND CHISEL SET, PUNCH, 1/2" DIA, 1/4" PT	1	G	7	26	
PUNCH AND CHISEL SET, PUNCH, 7/16" DIA, 7/32" PT	1	G	7	27	
PUNCH AND CHISEL SET, PUNCH, 3/8" DIA, 3/16" PT	1	G	7	28	
PUNCH AND CHISEL SET, PUNCH, 5/16" DIA, 1/8" PT	1	G	7	29	
PUNCH AND CHISEL SET, PUNCH, 1/4" DIA, 3/32" PT	1	G	7	30	
GOGGLES, INDUSTRIAL	1	G	7	31	

TM 9-4910-783-13&P

SATS FMM1 TOOL INVENTORY LIST

0059 00

INVENTORY

NOMENCLATURE	QTY	RACK	DRAWER	LOCATION	AMOUNT
PLIERS SET, RETAINING RING	1	G	8	2	
PULLER KIT, UNIVERSAL	1	G	8	3	
LIGHT, BATTERY 18V, RECHARGEABLE, CASE	1	G	8	1	

G, 8

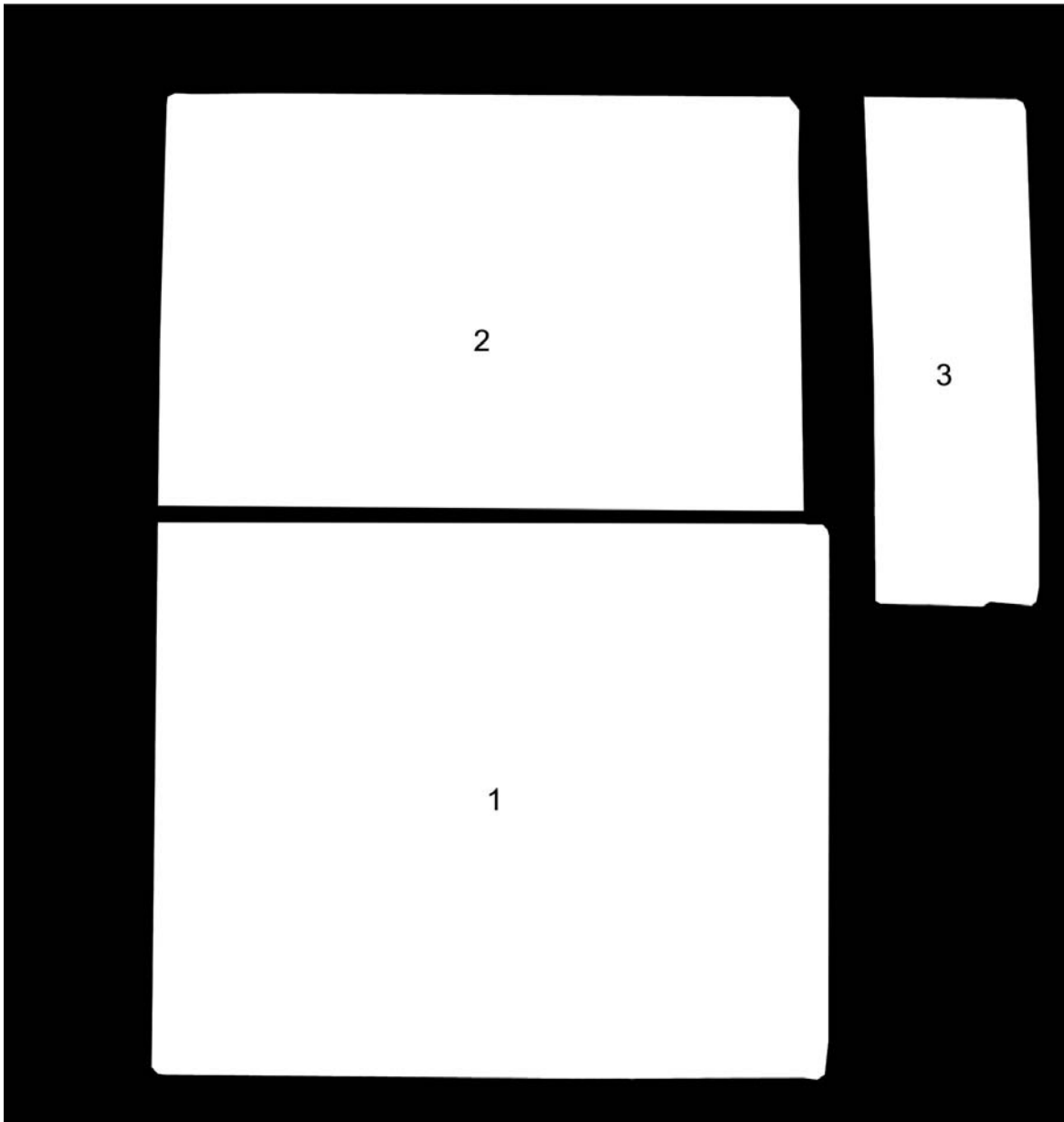

TM 9-4910-783-13&P

SATS FMM1 TOOL INVENTORY LIST

0059 00

INVENTORY

NOMENCLATURE	QTY	RACK	DRAWER	LOCATION	AMOUNT
SLING, ENGINE AND TRANSMISSION, 3 TON	1	M		1	
PLATE, BOLSTER, 36" X 36"	1	N		4	
PLATE, BOLSTER, 1 TON JACK, TRANSMISSION, 48" X 72"	1	N		5	

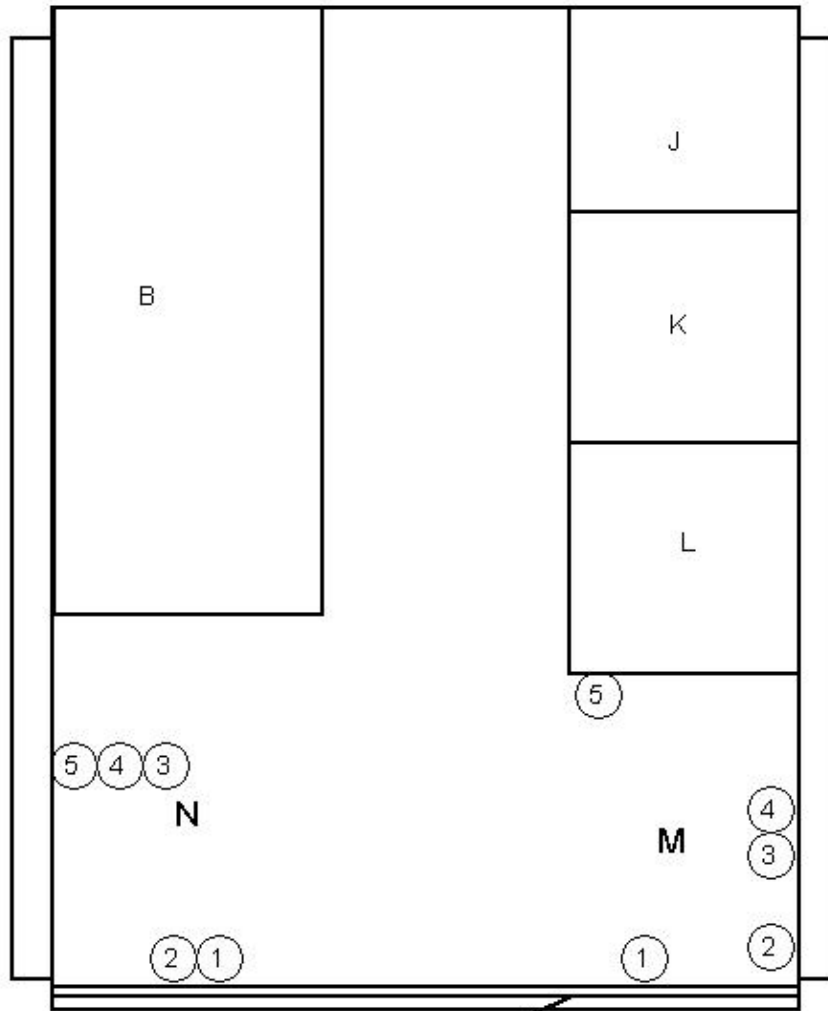

TM 9-4910-783-13&P

SATS FMM1 TOOL INVENTORY LIST

0059 00

INVENTORY

NOMENCLATURE	QTY	RACK	DRAWER	LOCATION	AMOUNT
GREASE GUN KIT	1	P		3	
BAR, TORQUE WRENCH	1	P		4	
TORQUE WRENCH MULTIPLIER	1	P		4	
WRENCH, TORQUE, CLICK, RATCHETING, 3/4" DRIVE, 600 FT-LB	2	P		8	

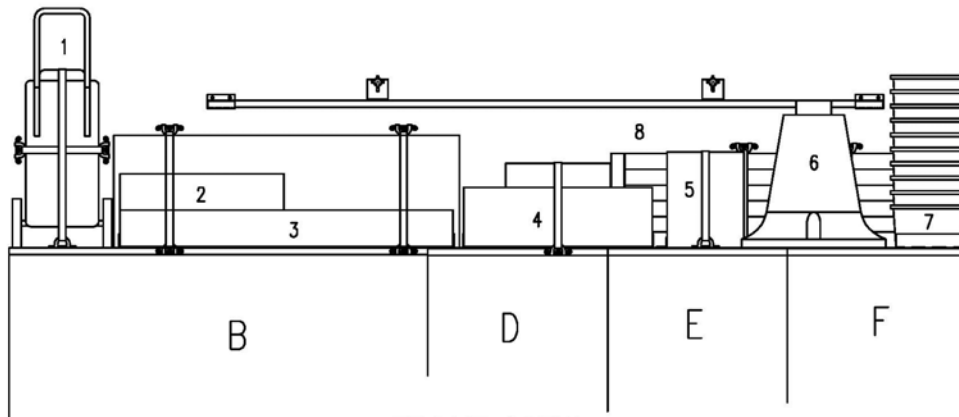
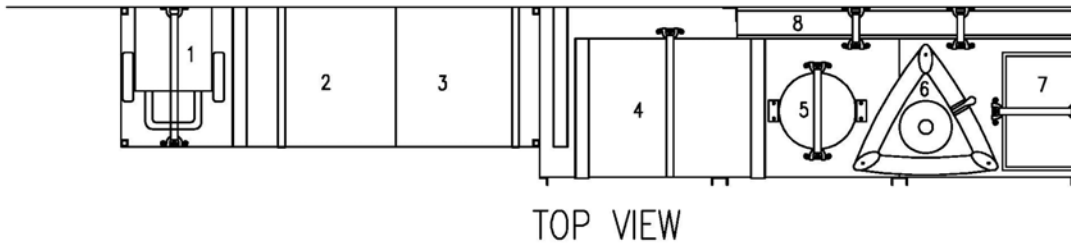

TM 9-4910-783-13&P

SATS FMM1 TOOL INVENTORY LIST

0059 00

NOMENCLATURE	QTY	RACK	DRAWER	LOCATION	INVENTORY AMOUNT
TRESTLE, HOIST, PORTABLE (NOTE: GFE ITEM)	2	Q		3	

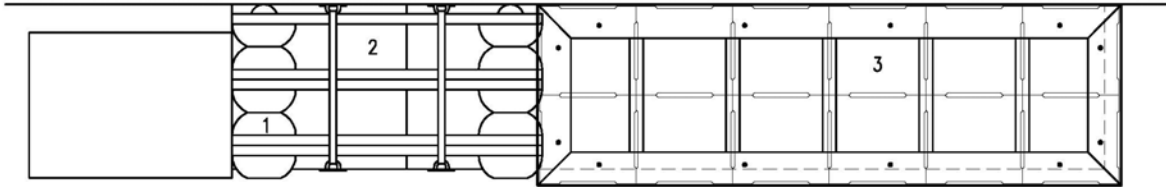

TOP VIEW

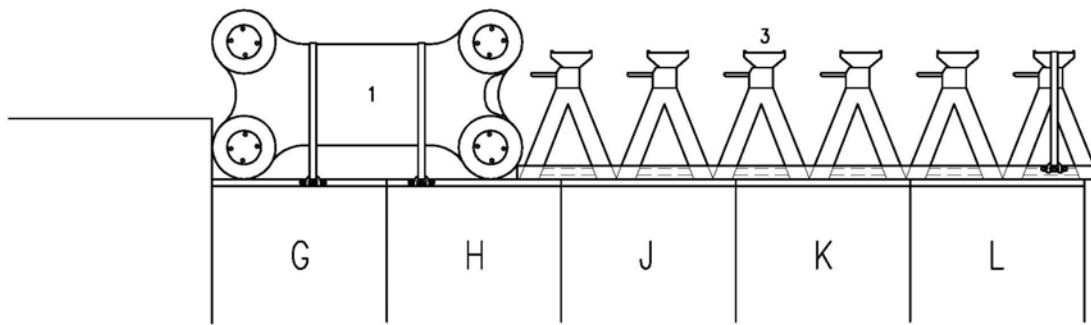

FRONT VIEW OF Q

TM 9-4910-783-13&P

APPENDIX C

FIELD MAINTENANCE MODULE 2 (FMM2) TOOLS

INVENTORY GUIDE

STANDARD AUTOMOTIVE TOOL SET (SATS)

TM 9-4910-783-13&P

SATS FIELD MAINTENANCE MODULE #2 (FMM2) COMPONENT LIST

0060 00

NOMENCLATURE	QTY	RACK	DRAWER	POSITION
ACCESSORIES, DRILL AND SANDER	1	D	6	9-12
ADAPTER KIT, GREASE GUN COUPLING	1	D	7	3
ADAPTER, 3/4" DR TO 1/2" DR, 1/2"	1	D	5	8
ADAPTER, 3/8" DR MALE TO 1/2" DR FEMALE	1	D	4	88
BAR, EXTENSION, IMPACT WRENCH, 3/8" DR, 2.5"	1	D	4	91
BAR, EXTENSION, 1/2" DR, 2.5"	1	D	4	80
BAR, EXTENSION, 1/2" DR, 4.5"	1	D	4	83
BAR, EXTENSION, 1/2" DR, 9.5"	1	D	4	85
BAR, EXTENSION, IMPACT WRENCH, 3/8" DR, 5.5"	1	D	4	87
BAR, PINCH, 60" (CROWBAR)	1	M		2
BEARING CUP PULLER ATTACHMENT	1	E	8	2
BEARING SPLITTER, 15/16" MAX	1	E	8	5
BEARING SPLITTER, 2" MAX	1	E	8	6
BEARING SPLITTER, 4-5/8" MAX	1	E	8	3
BLADE, ABRASIVE CUT-OFF	1	D	6	4
BLADE, ABRASIVE CUT-OFF, 36 GRIT FLAP WHEEL	1	D	6	2
BLADE, ABRASIVE CUT-OFF, 36 GRIT FLAP WHEEL	1	D	6	3
BLADE, HAND, HACKSAW	1	D	1	1
BOLTS	1	E	9	5
BOLTS FOR MECHANICAL PULLER SET	1	E	9	7
BOLTS FOR SLIDE HAMMER PULLER	1	E	9	8
BOX, TOTE	5	P		7
CABLE KIT, SPECIAL POWER	1	E	10	1
DRILL SET, LEFT-HAND TWIST	1	D	2	7
DRILL SET, TWIST	1	D	2	5
DRILL, ELECTRIC PORTABLE, 1/2"	1	D	6	5
DRILL, ELECTRIC, PORTABLE, 3/8"	1	D	6	1
DRILL, PNEUMATIC, RIGHT ANGLE	1	D	2	1
DRILL-DRIVER, ELECTRIC, 1/2"	1	D	6	7
DRILL-DRIVER, BATTERY OPERATED, RECHARGEABLE	1	D	2	6
EXTENSION ROD	1	E	9	3
EXTENSION ROD	1	E	9	4
EXTENSION, 3/4" DR, 15" LONG	1	D	5	1
EXTENSION, 3/4" DR, 4.5" LONG	1	D	5	3
EXTENSION, 3/4" DR, 7.5" LONG	1	D	5	2
EXTRACTOR SET, HARDENED SCREW	1	D	2	3
EXTRACTOR SET, SCREW	1	D	2	4

TM 9-4910-783-13&P

SATS FIELD MAINTENANCE MODULE #2 (FMM2) COMPONENT LIST

0060 00

NOMENCLATURE	QTY	RACK	DRAWER	POSITION
FEMALE THREADED ADAPTER, 1-1/4"	1	E	9	17
FEMALE THREADED ADAPTER, 1-1/8"	1	E	9	21
FEMALE THREADED ADAPTER, 1"	1	E	9	23
FEMALE THREADED ADAPTER, 1/2"	1	E	9	14
FEMALE THREADED ADAPTER, 3/4"	1	E	9	27
FEMALE THREADED ADAPTER, 5/8"	1	E	9	28
FEMALE THREADED ADAPTER, 7/8"	1	E	9	25
FLANGE-TYPE PULLER	1	E	9	1
GEAR AND PULLEY PULLERS, 13"	1	E	9	29
HAMMER BALL PEEN, DEAD BLOW, 1-13/16" FACE	1	D	1	5
HAMMER SET, HOLDER AND INSERTS, 2" HEAD	2	D	1	4,7
HAMMER, CLAW, STANDARD	1	D	1	6
HAMMER, DEAD BLOW, 1" HEAD	1	D	1	2
HAMMER, DEAD BLOW, 2" HEAD	1	D	1	3
HAMMER, SLEDGE, DOUBLE FACED, 10 LB	1	R		2
HANDLE, RATCHET, 3/4" DR, 17" LONG	1	D	5	11
HANDLE, SLIDING-T, 3/4" DR, 17" LONG	1	D	5	10
JACK, BOTTLE, HYDRAULIC, HAND, 12 TON	2	B	3	B1
JACK, BOTTLE, HYDRAULIC, HAND, 30 TON	1	B	3	B3
2-JAW PULLER, 13 TON, 11"	1	E	8	4
2-JAW PULLER, 2 TON, 3-1/4"	1	E	8	7
2-JAW PULLER, 7 TON, 5"	1	E	8	8
JOINT, UNIVERSAL, 1/2" DR	1	D	4	84
JOINT, UNIVERSAL, 3/4" DR	1	D	5	9
JOINT, UNIVERSAL, 3/8" DR	1	D	4	89
LIFT, TRANSMISSION AND DIFFERENTIAL	1	A		3b
LIGHT, BATTERY, OPERATED, RECHARGEABLE	1	D	3	2
MEASURE, LIQUID, 2 QUART	1	P		2
MEASURE, LIQUID, 8 QUART	1	P		2
OILER, HAND	1	D	7	1
OILER, HAND	1	D	7	2
PILOT BEARING PULLER	1	E	9	2
PLATE, BOLSTER, 1 TON JACK, TRANSMISSION, 48" X 72"	1	N		5
PLATE, BOLSTER, 12 TON JACK, 24" X 24"	2	N		3
PLATE, BOLSTER, 36" X 36"	1	N		4
PLIERS, LOCK RING	1	D	2	2
PLIERS, LOCK RING	1	D	2	8

TM 9-4910-783-13&P

SATS FIELD MAINTENANCE MODULE #2 (FMM2) COMPONENT LIST

0060 00

NOMENCLATURE	QTY	RACK	DRAWER	POSITION
PULLER SET, MECHANICAL	1	E	9	1-29
PULLER, PITTMAN ARM	1	E	8	1
PUSH PULLER W/ 6-3/4" LEGS	1	E	9	18
SANDER/GRINDER, 4-1/2"	1	D	6	6
SLIDE HAMMER PULLER	1	E	9	6
SOCKET, DOUBLE-END IMPACT, 3/4" X 13/16"	1	D	4	24
SOCKET, IMPACT WRENCH, 1/2" DR, 6 PT, 1-1/16"	1	D	4	75
SOCKET, IMPACT WRENCH, 1/2" DR, 6 PT, 1"	1	D	4	76
SOCKET, IMPACT WRENCH, 1/2" DR, 6 PT, 1/2"	1	D	4	71
SOCKET, IMPACT WRENCH, 1/2" DR, 6 PT, 11/16"	1	D	4	65
SOCKET, IMPACT WRENCH, 1/2" DR, 6 PT, 12MM	1	D	4	52
SOCKET, IMPACT WRENCH, 1/2" DR, 6 PT, 13/16"	1	D	4	79
SOCKET, IMPACT WRENCH, 1/2" DR, 6 PT, 13MM	1	D	4	63
SOCKET, IMPACT WRENCH, 1/2" DR, 6 PT, 14MM	1	D	4	68
SOCKET, IMPACT WRENCH, 1/2" DR, 6 PT, 15/16"	1	D	4	77
SOCKET, IMPACT WRENCH, 1/2" DR, 6 PT, 15MM	1	D	4	74
SOCKET, IMPACT WRENCH, 1/2" DR, 6 PT, 16MM	1	D	4	81
SOCKET, IMPACT WRENCH, 1/2" DR, 6 PT, 17MM	1	D	4	86
SOCKET, IMPACT WRENCH, 1/2" DR, 6 PT, 18MM	1	D	4	90
SOCKET, IMPACT WRENCH, 1/2" DR, 6 PT, 19MM	1	D	4	93
SOCKET, IMPACT WRENCH, 1/2" DR, 6 PT, 21MM	1	D	4	94
SOCKET, IMPACT WRENCH, 1/2" DR, 6 PT, 22MM	1	D	4	95
SOCKET, IMPACT WRENCH, 1/2" DR, 6 PT, 24MM	1	D	4	96
SOCKET, IMPACT WRENCH, 1/2" DR, 6 PT, 27MM	1	D	4	97
SOCKET, IMPACT WRENCH, 1/2" DR, 6 PT, 3/4"	1	D	4	73
SOCKET, IMPACT WRENCH, 1/2" DR, 6 PT, 3/8"	1	D	4	69
SOCKET, IMPACT WRENCH, 1/2" DR, 6 PT, 5/8"	1	D	4	64
SOCKET, IMPACT WRENCH, 1/2" DR, 6 PT, 7/16"	1	D	4	70
SOCKET, IMPACT WRENCH, 1/2" DR, 6 PT, 7/8"	1	D	4	78
SOCKET, IMPACT WRENCH, 1/2" DR, 6 PT, 9/16"	1	D	4	72
SOCKET, IMPACT WRENCH, 1/2" DR, 6 PT, DEEP, 1"	1	D	4	14
SOCKET, IMPACT WRENCH, 1/2" DR, 6 PT, DEEP, 1/2"	1	D	4	22
SOCKET, IMPACT WRENCH, 1/2" DR, 6 PT, DEEP, 11/16"	1	D	4	19
SOCKET, IMPACT WRENCH, 1/2" DR, 6 PT, DEEP, 1-1/16"	1	D	4	13
SOCKET, IMPACT WRENCH, 1/2" DR, 6 PT, DEEP, 12MM	1	D	4	1
SOCKET, IMPACT WRENCH, 1/2" DR, 6 PT, DEEP, 13/16"	1	D	4	17
SOCKET, IMPACT WRENCH, 1/2" DR, 6 PT, DEEP, 13MM	1	D	4	2

TM 9-4910-783-13&P

SATS FIELD MAINTENANCE MODULE #2 (FMM2) COMPONENT LIST

0060 00

NOMENCLATURE	QTY	RACK	DRAWER	POSITION
SOCKET, IMPACT WRENCH, 1/2" DR, 6 PT, DEEP, 14MM	1	D	4	3
SOCKET, IMPACT WRENCH, 1/2" DR, 6 PT, DEEP, 15/16"	1	D	4	15
SOCKET, IMPACT WRENCH, 1/2" DR, 6 PT, DEEP, 15MM	1	D	4	4
SOCKET, IMPACT WRENCH, 1/2" DR, 6 PT, DEEP, 16MM	1	D	4	5
SOCKET, IMPACT WRENCH, 1/2" DR, 6 PT, DEEP, 17MM	1	D	4	6
SOCKET, IMPACT WRENCH, 1/2" DR, 6 PT, DEEP, 18MM	1	D	4	7
SOCKET, IMPACT WRENCH, 1/2" DR, 6 PT, DEEP, 19MM	1	D	4	8
SOCKET, IMPACT WRENCH, 1/2" DR, 6 PT, DEEP, 21MM	1	D	4	9
SOCKET, IMPACT WRENCH, 1/2" DR, 6 PT, DEEP, 22MM	1	D	4	10
SOCKET, IMPACT WRENCH, 1/2" DR, 6 PT, DEEP, 24MM	1	D	4	11
SOCKET, IMPACT WRENCH, 1/2" DR, 6 PT, DEEP, 27MM	1	D	4	12
SOCKET, IMPACT WRENCH, 1/2" DR, 6 PT, DEEP, 3/4"	1	D	4	18
SOCKET, IMPACT WRENCH, 1/2" DR, 6 PT, DEEP, 3/8"	1	D	4	38
SOCKET, IMPACT WRENCH, 1/2" DR, 6 PT, DEEP, 5/8"	1	D	4	20
SOCKET, IMPACT WRENCH, 1/2" DR, 6 PT, DEEP, 7/16"	1	D	4	23
SOCKET, IMPACT WRENCH, 1/2" DR, 6 PT, DEEP, 7/8"	1	D	4	16
SOCKET, IMPACT WRENCH, 1/2" DR, 6 PT, DEEP, 9/16"	1	D	4	21
SOCKET, IMPACT WRENCH, 3/8" DR, 6 PT, 1/2"	1	D	4	50
SOCKET, IMPACT WRENCH, 3/8" DR, 6 PT, 1/4"	1	D	4	66
SOCKET, IMPACT WRENCH, 3/8" DR, 6 PT, 10MM	1	D	4	28
SOCKET, IMPACT WRENCH, 3/8" DR, 6 PT, 11/16"	1	D	4	47
SOCKET, IMPACT WRENCH, 3/8" DR, 6 PT, 11MM	1	D	4	29
SOCKET, IMPACT WRENCH, 3/8" DR, 6 PT, 12MM	1	D	4	30
SOCKET, IMPACT WRENCH, 3/8" DR, 6 PT, 13MM	1	D	4	31
SOCKET, IMPACT WRENCH, 3/8" DR, 6 PT, 14MM	1	D	4	32
SOCKET, IMPACT WRENCH, 3/8" DR, 6 PT, 15MM	1	D	4	33
SOCKET, IMPACT WRENCH, 3/8" DR, 6 PT, 16MM	1	D	4	34
SOCKET, IMPACT WRENCH, 3/8" DR, 6 PT, 17MM	1	D	4	35
SOCKET, IMPACT WRENCH, 3/8" DR, 6 PT, 18MM	1	D	4	36
SOCKET, IMPACT WRENCH, 3/8" DR, 6 PT, 19MM	1	D	4	37
SOCKET, IMPACT WRENCH, 3/8" DR, 6 PT, 3/4"	1	D	4	46
SOCKET, IMPACT WRENCH, 3/8" DR, 6 PT, 3/8"	1	D	4	62
SOCKET, IMPACT WRENCH, 3/8" DR, 6 PT, 5/16"	1	D	4	67
SOCKET, IMPACT WRENCH, 3/8" DR, 6 PT, 5/8"	1	D	4	48
SOCKET, IMPACT WRENCH, 3/8" DR, 6 PT, 7/16"	1	D	4	51
SOCKET, IMPACT WRENCH, 3/8" DR, 6 PT, 9/16"	1	D	4	49
SOCKET, IMPACT WRENCH, 3/8" DR, 6 PT, DEEP, 1/2"	1	D	4	57

TM 9-4910-783-13&P

SATS FIELD MAINTENANCE MODULE #2 (FMM2) COMPONENT LIST

0060 00

NOMENCLATURE	QTY	RACK	DRAWER	POSITION
SOCKET, IMPACT WRENCH, 3/8" DR, 6 PT, DEEP, 1/4"	1	D	4	61
SOCKET, IMPACT WRENCH, 3/8" DR, 6 PT, DEEP, 10MM	1	D	4	27
SOCKET, IMPACT WRENCH, 3/8" DR, 6 PT, DEEP, 11/16"	1	D	4	54
SOCKET, IMPACT WRENCH, 3/8" DR, 6 PT, DEEP, 11MM	1	D	4	26
SOCKET, IMPACT WRENCH, 3/8" DR, 6 PT, DEEP, 12MM	1	D	4	25
SOCKET, IMPACT WRENCH, 3/8" DR, 6 PT, DEEP, 13MM	1	D	4	39
SOCKET, IMPACT WRENCH, 3/8" DR, 6 PT, DEEP, 14MM	1	D	4	40
SOCKET, IMPACT WRENCH, 3/8" DR, 6 PT, DEEP, 15MM	1	D	4	41
SOCKET, IMPACT WRENCH, 3/8" DR, 6 PT, DEEP, 16MM	1	D	4	42
SOCKET, IMPACT WRENCH, 3/8" DR, 6 PT, DEEP, 17MM	1	D	4	43
SOCKET, IMPACT WRENCH, 3/8" DR, 6 PT, DEEP, 18MM	1	D	4	44
SOCKET, IMPACT WRENCH, 3/8" DR, 6 PT, DEEP, 19MM	1	D	4	45
SOCKET, IMPACT WRENCH, 3/8" DR, 6 PT, DEEP, 3/4"	1	D	4	53
SOCKET, IMPACT WRENCH, 3/8" DR, 6 PT, DEEP, 3/8"	1	D	4	59
SOCKET, IMPACT WRENCH, 3/8" DR, 6 PT, DEEP, 5/16"	1	D	4	60
SOCKET, IMPACT WRENCH, 3/8" DR, 6 PT, DEEP, 5/8"	1	D	4	55
SOCKET, IMPACT WRENCH, 3/8" DR, 6 PT, DEEP, 7/16"	1	D	4	58
SOCKET, IMPACT WRENCH, 3/8" DR, 6 PT, DEEP, 9/16"	1	D	4	56
SOCKET, SOCKET WRENCH, 3/4" DR, 12 PT, 1-1/16"	1	D	5	4
SOCKET, SOCKET WRENCH, 3/4" DR, 12 PT, 1-1/2"	1	D	5	21
SOCKET, SOCKET WRENCH, 3/4" DR, 12 PT, 1-1/4"	1	D	5	13
SOCKET, SOCKET WRENCH, 3/4" DR, 12 PT, 1-1/8"	1	D	5	12
SOCKET, SOCKET WRENCH, 3/4" DR, 12 PT, 1-13/16"	1	D	5	22
SOCKET, SOCKET WRENCH, 3/4" DR, 12 PT, 1-3/4"	1	D	5	17
SOCKET, SOCKET WRENCH, 3/4" DR, 12 PT, 1-3/8"	1	D	5	15
SOCKET, SOCKET WRENCH, 3/4" DR, 12 PT, 1-5/16"	1	D	5	14
SOCKET, SOCKET WRENCH, 3/4" DR, 12 PT, 1-5/8"	1	D	5	19
SOCKET, SOCKET WRENCH, 3/4" DR, 12 PT, 1-7/16"	1	D	5	16
SOCKET, SOCKET WRENCH, 3/4" DR, 12 PT, 1-7/8"	1	D	5	23
SOCKET, SOCKET WRENCH, 3/4" DR, 12 PT, 1-9/16"	1	D	5	20
SOCKET, SOCKET WRENCH, 3/4" DR, 12 PT, 1"	1	D	5	5
SOCKET, SOCKET WRENCH, 3/4" DR, 12 PT, 15/16"	1	D	5	6
SOCKET, SOCKET WRENCH, 3/4" DR, 12 PT, 2-1/16"	1	D	5	25
SOCKET, SOCKET WRENCH, 3/4" DR, 12 PT, 2-1/4"	1	D	5	28
SOCKET, SOCKET WRENCH, 3/4" DR, 12 PT, 2-1/8"	1	D	5	26
SOCKET, SOCKET WRENCH, 3/4" DR, 12 PT, 2-3/16"	1	D	5	27
SOCKET, SOCKET WRENCH, 3/4" DR, 12 PT, 2-3/8"	1	D	5	29

TM 9-4910-783-13&P

SATS FIELD MAINTENANCE MODULE #2 (FMM2) COMPONENT LIST

0060 00

NOMENCLATURE	QTY	RACK	DRAWER	POSITION
SOCKET, SOCKET WRENCH, 3/4" DR, 12 PT, 2"	1	D	5	24
SOCKET, SOCKET WRENCH, 3/4" DR, 12 PT, 7/8"	1	D	5	7
SOCKET, SOCKET WRENCH, 3/4" DR, 12 PT, 1-11/16"	1	D	5	18
STEERING WHEEL PULLER	1	E	9	11
STEP PLATE ADAPTER, 1-1/8"	1	E	9	22
STEP PLATE ADAPTER, 1-1/4"	1	E	9	24
STEP PLATE ADAPTER, 1-3/4"	1	E	9	16
STEP PLATE ADAPTER, 1-3/8"	1	E	9	26
STEP PLATE ADAPTER, 1-5/8"	1	E	9	20
STEP PLATE ADAPTER, 1-7/8"	1	E	9	12
STEP PLATE ADAPTER, 1"	1	E	9	19
STEP PLATE ADAPTER, 2-1/2"	1	E	9	9
STEP PLATE ADAPTER, 2-1/8"	1	E	9	13
STEP PLATE ADAPTER, 2-3/8"	1	E	9	10
STEP PLATE ADAPTER, 2"	1	E	9	15
TOOL KIT, CUTTING, ABRASIVE, PNEUMATIC	1	D	3	1
WRENCH, ELECTRIC IMPACT, 1/2" SQ DR,	1	D	4	82
WRENCH, PNEUMATIC IMPACT, 1/2" SQ DR,	1	D	4	92

TM 9-4910-783-13&P

SATS FMM2 INVENTORY LIST

0060 00

				INVENTORY	
NOMENCLATURE	QTY	RACK	DRAWER	LOCATION	AMOUNT
LIFT, TRANSMISSION AND DIFFERENTIAL	1	A		3b	

A – Floor Positions

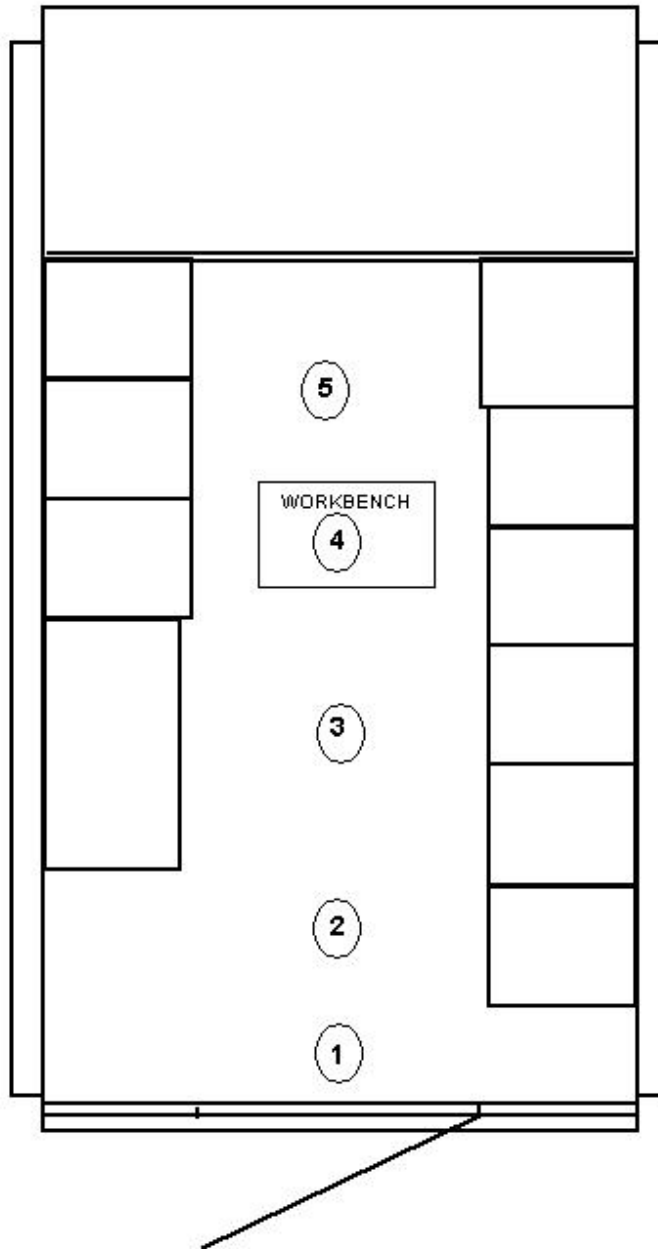

TM 9-4910-783-13&P

SATS FMM2 INVENTORY LIST

0060 00

	INVENTORY				
NOMENCLATURE	QTY	RACK	SHELF	LOCATION	AMOUNT
JACK, BOTTLE, HYDRAULIC, HAND, 12 TON	2	B	3	B1	
JACK, BOTTLE, HYDRAULIC, HAND, 30 TON	1	B	3	B3	

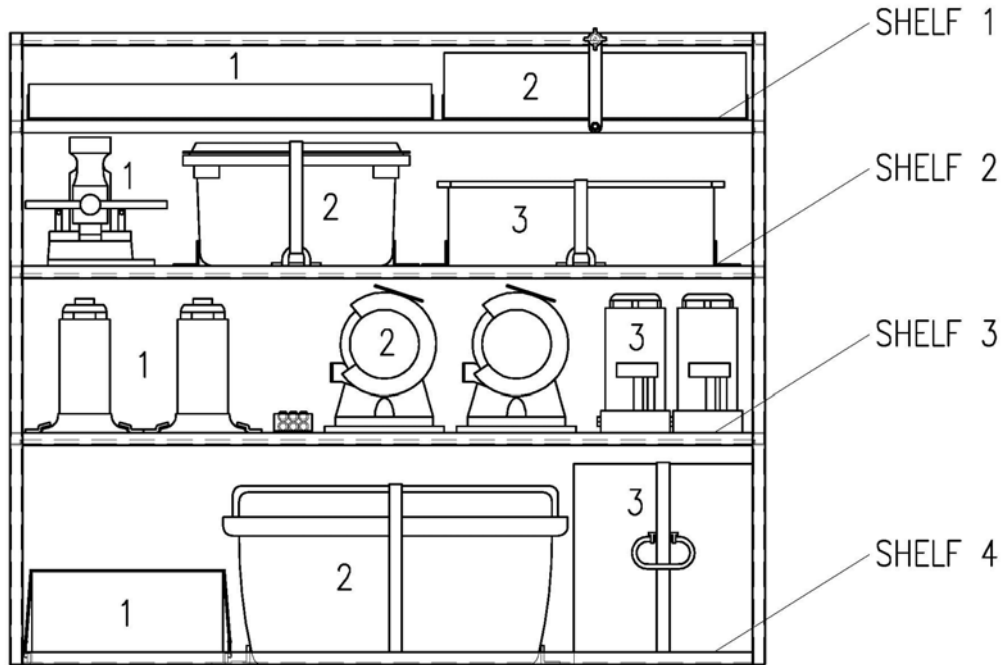

FRONT VIEW OF B

TM 9-4910-783-13&P

SATS FMM2 INVENTORY LIST

0060 00

NOMENCLATURE	QTY	RACK	DRAWER	LOCATION	INVENTORY AMOUNT
BLADE, HAND, HACKSAW	1	D	1	1	
HAMMER, DEAD BLOW, 1" HEAD	1	D	1	2	
HAMMER, DEAD BLOW, 2" HEAD	1	D	1	3	
HAMMER BALL PEEN, DEAD BLOW, 1-13/16" FACE	1	D	1	5	
HAMMER, CLAW, STANDARD	1	D	1	6	
HAMMER SET, HOLDER AND INSERTS, 2" HEAD	2	D	1	4,7	

D, 1

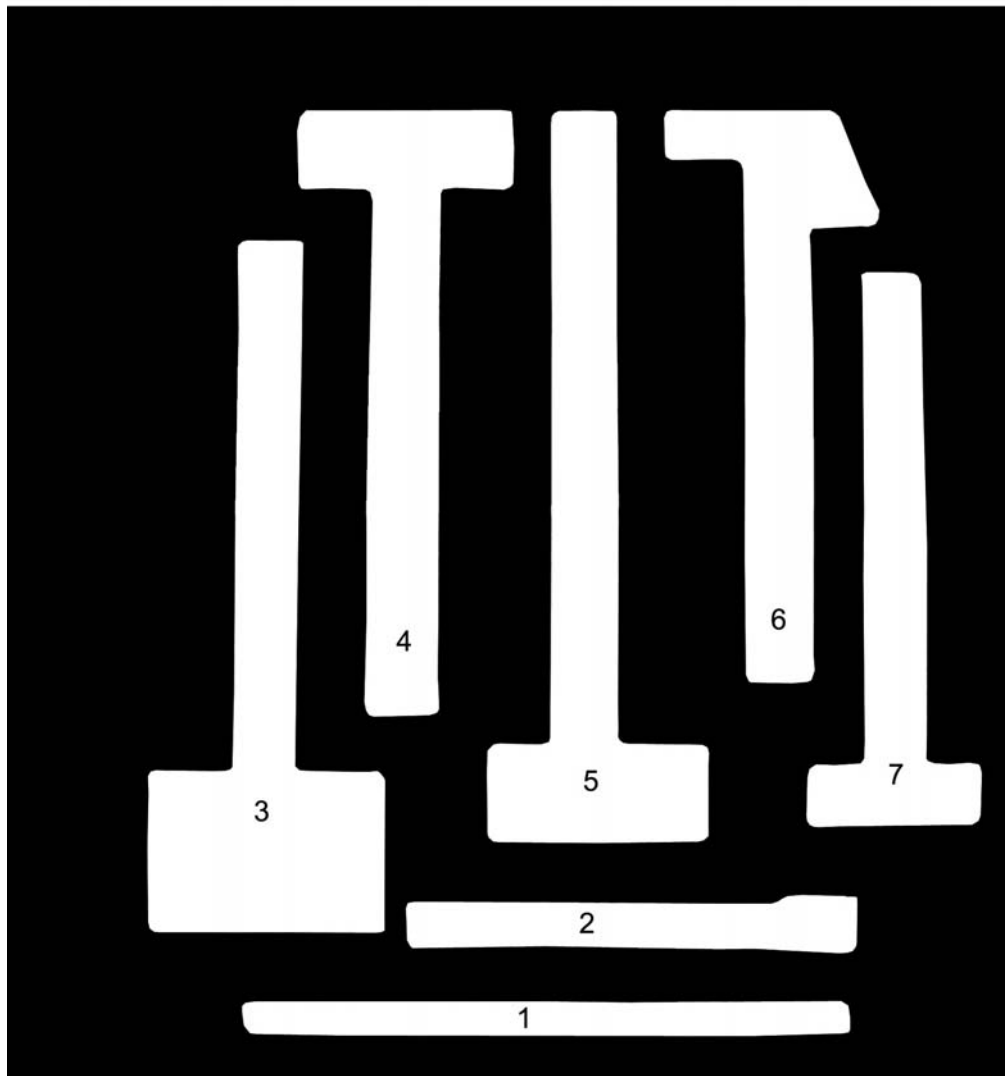

TM 9-4910-783-13&P

SATS FMM2 INVENTORY LIST

0060 00

INVENTORY

NOMENCLATURE	QTY	RACK	DRAWER	LOCATION	AMOUNT
DRILL, PNEUMATIC, RIGHT ANGLE	1	D	2	1	
PLIERS, LOCK RING	1	D	2	2	
EXTRACTOR SET, HARDENED SCREW	1	D	2	3	
EXTRACTOR SET, SCREW	1	D	2	4	
DRILL SET, TWIST	2	D	2	5	
DRILL-DRIVER, BATTERY OPERATED, RECHARGEABLE	1	D	2	6	
DRILL SET, LEFT-HAND TWIST	1	D	2	7	
PLIERS, LOCK RING	1	D	2	8	

D, 2

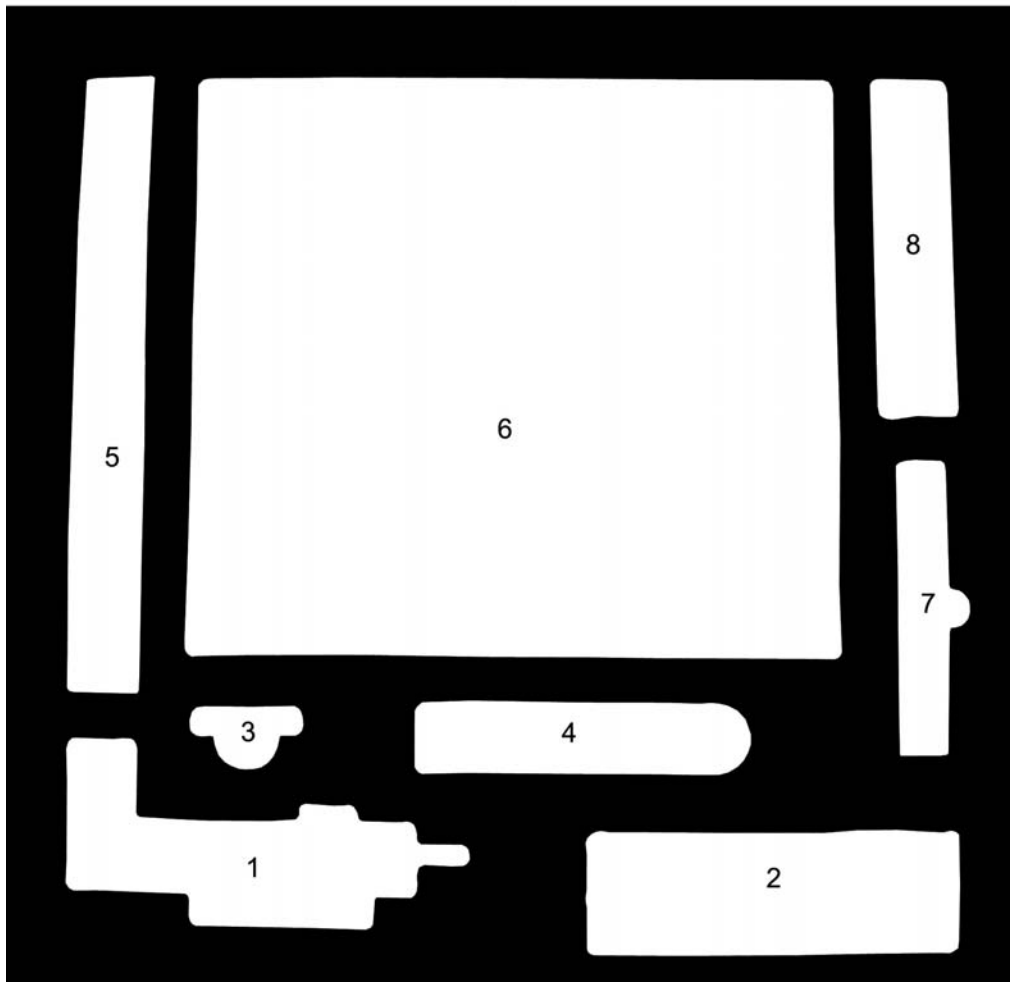

TM 9-4910-783-13&P

SATS FMM2 INVENTORY LIST

0060 00

INVENTORY

NOMENCLATURE	QTY	RACK	DRAWER	LOCATION	AMOUNT
TOOL KIT, CUTTING, ABRASIVE, PNEUMATIC	1	D	3	1	
LIGHT, BATTERY, OPERATED, RECHARGEABLE	1	D	3	2	

D, 3

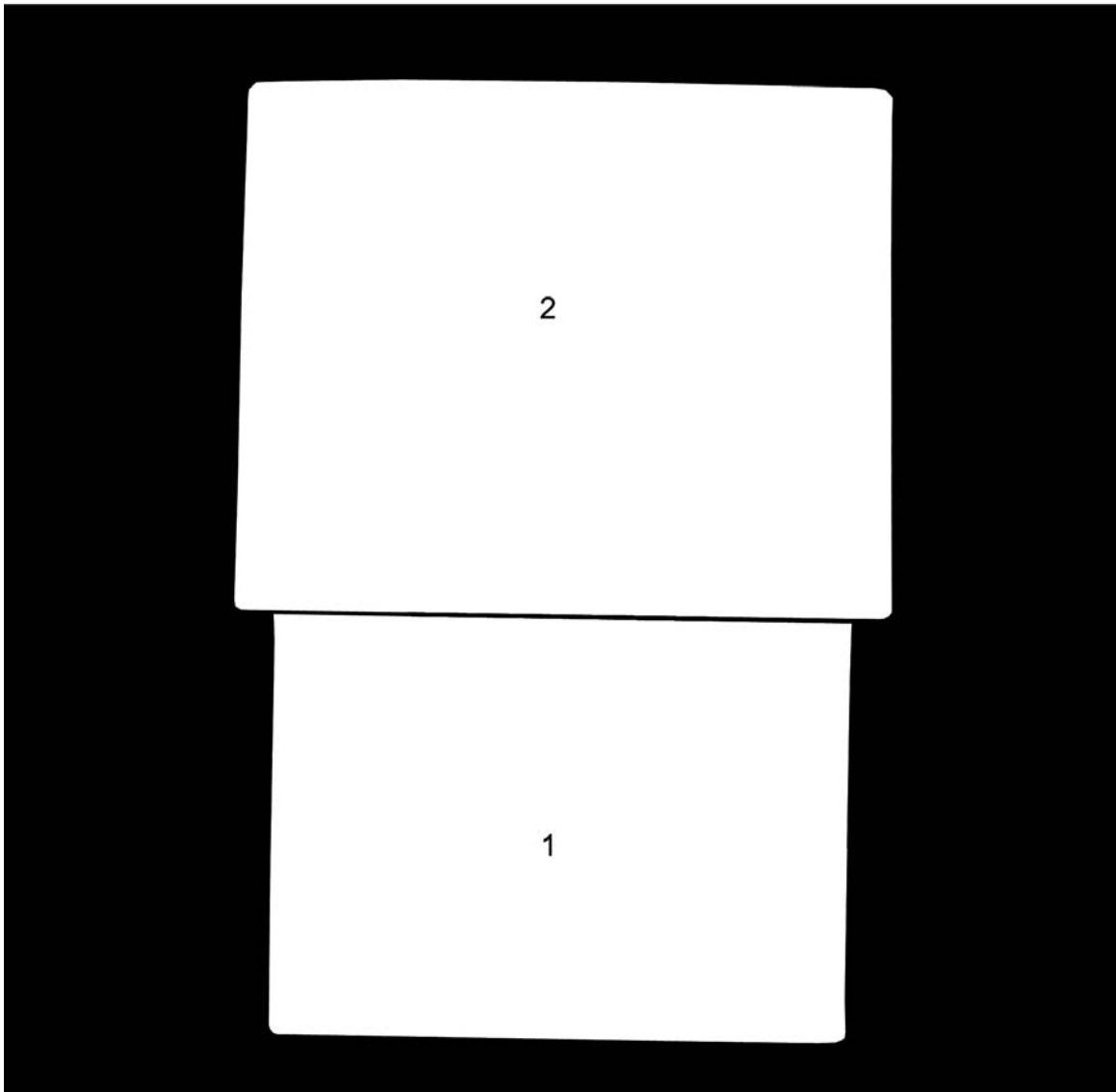

TM 9-4910-783-13&P

D, 4

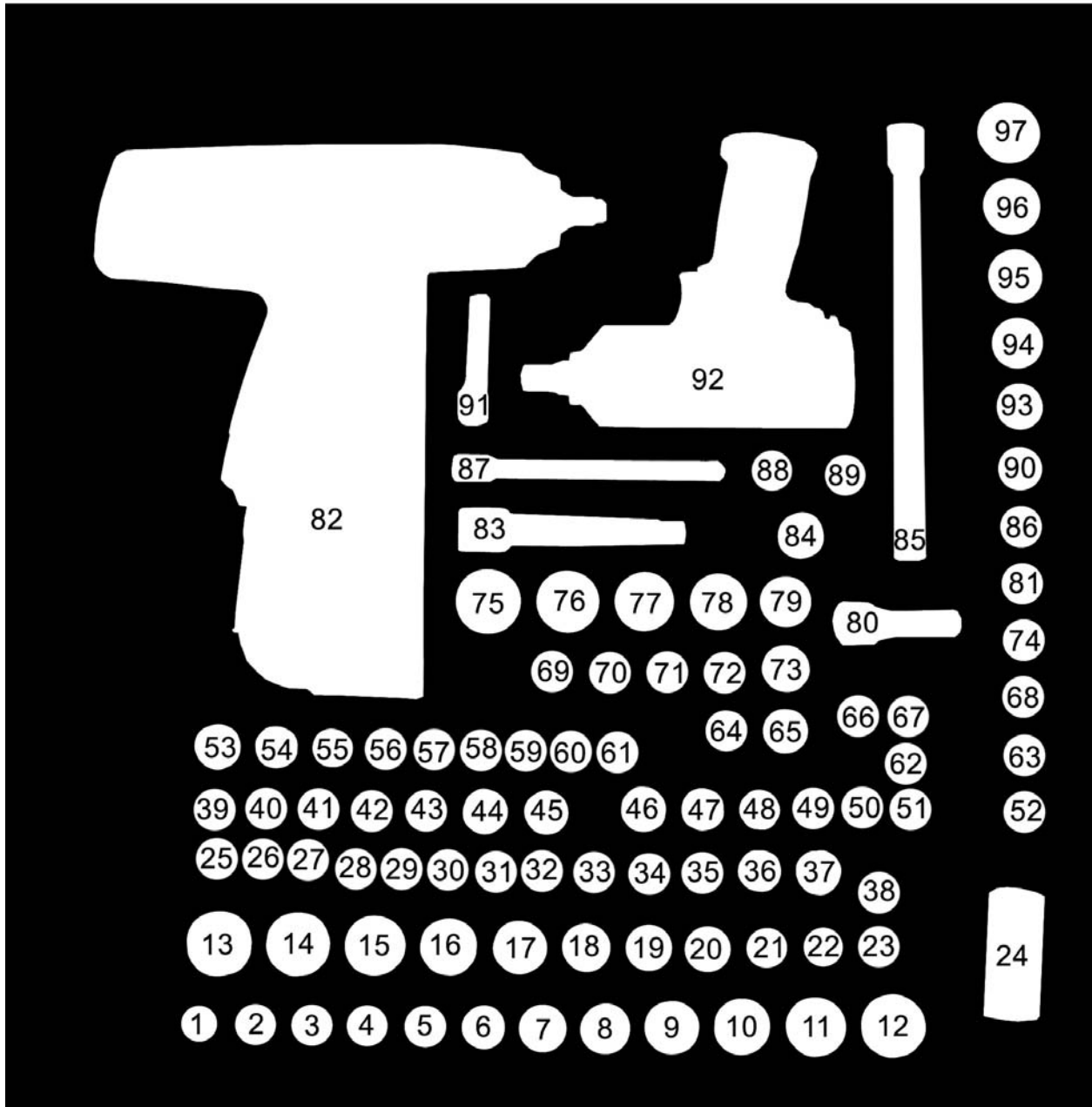

TM 9-4910-783-13&P

SATS FMM2 INVENTORY LIST

0060 00

INVENTORY

NOMENCLATURE	QTY	RACK	DRAWER	LOCATION	AMOUNT
SOCKET, IMPACT WRENCH, 1/2" DR, 6 PT, DEEP, 12MM	1	D	4	1	
SOCKET, IMPACT WRENCH, 1/2" DR, 6 PT, DEEP, 13MM	1	D	4	2	
SOCKET, IMPACT WRENCH, 1/2" DR, 6 PT, DEEP, 14MM	1	D	4	3	
SOCKET, IMPACT WRENCH, 1/2" DR, 6 PT, DEEP, 15MM	1	D	4	4	
SOCKET, IMPACT WRENCH, 1/2" DR, 6 PT, DEEP, 16MM	1	D	4	5	
SOCKET, IMPACT WRENCH, 1/2" DR, 6 PT, DEEP, 17MM	1	D	4	6	
SOCKET, IMPACT WRENCH, 1/2" DR, 6 PT, DEEP, 18MM	1	D	4	7	
SOCKET, IMPACT WRENCH, 1/2" DR, 6 PT, DEEP, 19MM	1	D	4	8	
SOCKET, IMPACT WRENCH, 1/2" DR, 6 PT, DEEP, 21MM	1	D	4	9	
SOCKET, IMPACT WRENCH, 1/2" DR, 6 PT, DEEP, 22MM	1	D	4	10	
SOCKET, IMPACT WRENCH, 1/2" DR, 6 PT, DEEP, 24MM	1	D	4	11	
SOCKET, IMPACT WRENCH, 1/2" DR, 6 PT, DEEP, 27MM	1	D	4	12	
SOCKET, IMPACT WRENCH, 1/2" DR, 6 PT, DEEP, 1-1/16"	1	D	4	13	
SOCKET, IMPACT WRENCH, 1/2" DR, 6 PT, DEEP, 1"	1	D	4	14	
SOCKET, IMPACT WRENCH, 1/2" DR, 6 PT, DEEP, 15/16"	1	D	4	15	
SOCKET, IMPACT WRENCH, 1/2" DR, 6 PT, DEEP, 7/8"	1	D	4	16	
SOCKET, IMPACT WRENCH, 1/2" DR, 6 PT, DEEP, 13/16"	1	D	4	17	
SOCKET, IMPACT WRENCH, 1/2" DR, 6 PT, DEEP, 3/4"	1	D	4	18	
SOCKET, IMPACT WRENCH, 1/2" DR, 6 PT, DEEP, 11/16"	1	D	4	19	
SOCKET, IMPACT WRENCH, 1/2" DR, 6 PT, DEEP, 5/8"	1	D	4	20	
SOCKET, IMPACT WRENCH, 1/2" DR, 6 PT, DEEP, 9/16"	1	D	4	21	
SOCKET, IMPACT WRENCH, 1/2" DR, 6 PT, DEEP, 1/2"	1	D	4	22	
SOCKET, IMPACT WRENCH, 1/2" DR, 6 PT, DEEP, 7/16"	1	D	4	23	
SOCKET, DOUBLE-END IMPACT, 3/4" X 13/16"	1	D	4	24	
SOCKET, IMPACT WRENCH, 3/8" DR, 6 PT, DEEP, 12MM	1	D	4	25	
SOCKET, IMPACT WRENCH, 3/8" DR, 6 PT, DEEP, 11MM	1	D	4	26	
SOCKET, IMPACT WRENCH, 3/8" DR, 6 PT, DEEP, 10MM	1	D	4	27	
SOCKET, IMPACT WRENCH, 3/8" DR, 6 PT, 10MM	1	D	4	28	
SOCKET, IMPACT WRENCH, 3/8" DR, 6 PT, 11MM	1	D	4	29	
SOCKET, IMPACT WRENCH, 3/8" DR, 6 PT, 12MM	1	D	4	30	
SOCKET, IMPACT WRENCH, 3/8" DR, 6 PT, 13MM	1	D	4	31	
SOCKET, IMPACT WRENCH, 3/8" DR, 6 PT, 14MM	1	D	4	32	
SOCKET, IMPACT WRENCH, 3/8" DR, 6 PT, 15MM	1	D	4	33	
SOCKET, IMPACT WRENCH, 3/8" DR, 6 PT, 16MM	1	D	4	34	
SOCKET, IMPACT WRENCH, 3/8" DR, 6 PT, 17MM	1	D	4	35	
SOCKET, IMPACT WRENCH, 3/8" DR, 6 PT, 18MM	1	D	4	36	
SOCKET, IMPACT WRENCH, 3/8" DR, 6 PT, 19MM	1	D	4	37	

TM 9-4910-783-13&P

SATS FMM2 INVENTORY LIST

0060 00

					INVENTORY
NOMENCLATURE	QTY	RACK	DRAWER	LOCATION	AMOUNT
SOCKET, IMPACT WRENCH, 1/2" DR, 6 PT, DEEP, 3/8"	1	D	4	38	
SOCKET, IMPACT WRENCH, 3/8" DR, 6 PT, DEEP, 13MM	1	D	4	39	
SOCKET, IMPACT WRENCH, 3/8" DR, 6 PT, DEEP, 14MM	1	D	4	40	
SOCKET, IMPACT WRENCH, 3/8" DR, 6 PT, DEEP, 15MM	1	D	4	41	
SOCKET, IMPACT WRENCH, 3/8" DR, 6 PT, DEEP, 16MM	1	D	4	42	
SOCKET, IMPACT WRENCH, 3/8" DR, 6 PT, DEEP, 17MM	1	D	4	43	
SOCKET, IMPACT WRENCH, 3/8" DR, 6 PT, DEEP, 18MM	1	D	4	44	
SOCKET, IMPACT WRENCH, 3/8" DR, 6 PT, DEEP, 19MM	1	D	4	45	
SOCKET, IMPACT WRENCH, 3/8" DR, 6 PT, 3/4"	1	D	4	46	
SOCKET, IMPACT WRENCH, 3/8" DR, 6 PT, 11/16"	1	D	4	47	
SOCKET, IMPACT WRENCH, 3/8" DR, 6 PT, 5/8"	1	D	4	48	
SOCKET, IMPACT WRENCH, 3/8" DR, 6PT, 9/16"	1	D	4	49	
SOCKET, IMPACT WRENCH, 3/8" DR, 6 PT, 1/2"	1	D	4	50	
SOCKET, IMPACT WRENCH, 3/8" DR, 6 PT, 7/16"	1	D	4	51	
SOCKET, IMPACT WRENCH, 1/2" DR, 6 PT, 12MM	1	D	4	52	
SOCKET, IMPACT WRENCH, 3/8" DR, 6 PT, DEEP, 3/4"	1	D	4	53	
SOCKET, IMPACT WRENCH, 3/8" DR, 6 PT, DEEP, 11/16"	1	D	4	54	
SOCKET, IMPACT WRENCH, 3/8" DR, 6 PT, DEEP, 5/8"	1	D	4	55	
SOCKET, IMPACT WRENCH, 3/8" DR, 6 PT, DEEP, 9/16"	1	D	4	56	
SOCKET, IMPACT WRENCH, 3/8" DR, 6 PT, DEEP, 1/2"	1	D	4	57	
SOCKET, IMPACT WRENCH, 3/8" DR, 6 PT, DEEP, 7/16"	1	D	4	58	
SOCKET, IMPACT WRENCH, 3/8" DR, 6 PT, DEEP, 3/8"	1	D	4	59	
SOCKET, IMPACT WRENCH, 3/8" DR, 6 PT, DEEP, 5/16"	1	D	4	60	
SOCKET, IMPACT WRENCH, 3/8" DR, 6 PT, DEEP, 1/4"	1	D	4	61	
SOCKET, IMPACT WRENCH, 3/8" DR, 6 PT, 3/8"	1	D	4	62	
SOCKET, IMPACT WRENCH, 1/2" DR, 6 PT, 13MM	1	D	4	63	
SOCKET, IMPACT WRENCH, 1/2" DR, 6 PT, 5/8"	1	D	4	64	
SOCKET, IMPACT WRENCH, 1/2" DR, 6 PT, 11/16"	1	D	4	65	
SOCKET, IMPACT WRENCH, 3/8" DR, 6 PT, 1/4"	1	D	4	66	
SOCKET, IMPACT WRENCH, 3/8" DR, 6 PT, 5/16"	1	D	4	67	
SOCKET, IMPACT WRENCH, 1/2" DR, 6 PT, 14MM	1	D	4	68	
SOCKET, IMPACT WRENCH, 1/2" DR, 6 PT, 3/8"	1	D	4	69	
SOCKET, IMPACT WRENCH, 1/2" DR, 6 PT, 7/16"	1	D	4	70	
SOCKET, IMPACT WRENCH, 1/2" DR, 6 PT, 1/2"	1	D	4	71	
SOCKET, IMPACT WRENCH, 1/2" DR, 6 PT, 9/16"	1	D	4	72	
SOCKET, IMPACT WRENCH, 1/2" DR, 6 PT, 3/4"	1	D	4	73	
SOCKET, IMPACT WRENCH, 1/2" DR, 6 PT, 15MM	1	D	4	74	

TM 9-4910-783-13&P

SATS FMM2 INVENTORY LIST

0060 00

NOMENCLATURE	QTY	RACK	DRAWER	LOCATION	INVENTORY AMOUNT
SOCKET, IMPACT WRENCH, 1/2" DR, 6 PT, 1-1/16"	1	D	4	75	
SOCKET, IMPACT WRENCH, 1/2" DR, 6 PT, 1"	1	D	4	76	
SOCKET, IMPACT WRENCH, 1/2" DR, 6 PT, 15/16"	1	D	4	77	
SOCKET, IMPACT WRENCH, 1/2" DR, 6 PT, 7/8"	1	D	4	78	
SOCKET, IMPACT WRENCH, 1/2" DR, 6 PT, 13/16"	1	D	4	79	
BAR, EXTENSION, 1/2" DR, 2.5"	1	D	4	80	
SOCKET, IMPACT WRENCH, 1/2" DR, 6 PT, 16MM	1	D	4	81	
WRENCH, ELECTRIC IMPACT, 1/2" SQ DR,	1	D	4	82	
BAR, EXTENSION, 1/2" DR, 4.5"	1	D	4	83	
JOINT, UNIVERSAL, 1/2" DR	1	D	4	84	
BAR, EXTENSION, 1/2" DR, 9.5"	1	D	4	85	
SOCKET, IMPACT WRENCH, 1/2" DR, 6 PT, 17MM	1	D	4	86	
BAR, EXTENSION, IMPACT WRENCH, 3/8" DR, 5.5"	1	D	4	87	
ADAPTER, 3/8" DR MALE TO 1/2" DR FEMALE	1	D	4	88	
JOINT, UNIVERSAL, 3/8" DR	1	D	4	89	
SOCKET, IMPACT WRENCH, 1/2" DR, 6 PT, 18MM	1	D	4	90	
BAR, EXTENSION, IMPACT WRENCH, 3/8" DR, 2.5"	1	D	4	91	
WRENCH, PNEUMATIC IMPACT, 1/2" SQ DR,	1	D	4	92	
SOCKET, IMPACT WRENCH, 1/2" DR, 6 PT, 19MM	1	D	4	93	
SOCKET, IMPACT WRENCH, 1/2" DR, 6 PT, 21MM	1	D	4	94	
SOCKET, IMPACT WRENCH, 1/2" DR, 6 PT, 22MM	1	D	4	95	
SOCKET, IMPACT WRENCH, 1/2" DR, 6 PT, 24MM	1	D	4	96	
SOCKET, IMPACT WRENCH, 1/2" DR, 6 PT, 27MM	1	D	4	97	

TM 9-4910-783-13&P

SATS FMM2 INVENTORY LIST

0060 00

D, 5

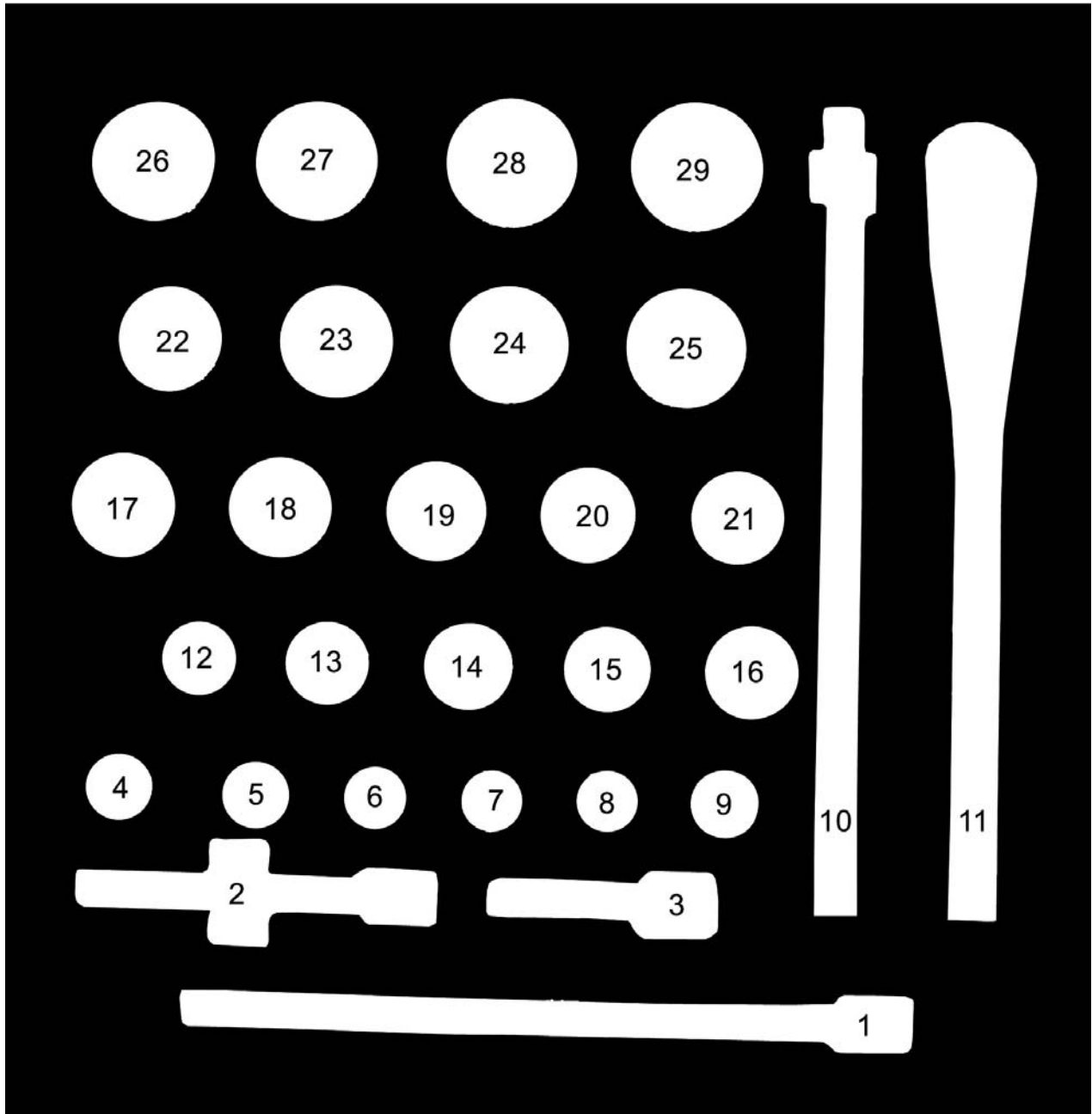

TM 9-4910-783-13&P

SATS FMM2 INVENTORY LIST

0060 00

INVENTORY

NOMENCLATURE	QTY	RACK	DRAWER	LOCATION	AMOUNT
EXTENSION, 3/4" DR, 15" LONG	1	D	5	1	
EXTENSION, 3/4" DR, 7.5" LONG	1	D	5	2	
EXTENSION, 3/4" DR, 4.5" LONG	1	D	5	3	
SOCKET, SOCKET WRENCH, 3/4" DR, 12 PT, 1-1/16"	1	D	5	4	
SOCKET, SOCKET WRENCH, 3/4" DR, 12 PT, 1"	1	D	5	5	
SOCKET, SOCKET WRENCH, 3/4" DR, 12 PT, 15/16"	1	D	5	6	
SOCKET, SOCKET WRENCH, 3/4" DR, 12 PT, 7/8"	1	D	5	7	
ADAPTER, 3/4" DR TO 1/2" DR, 1/2"	1	D	5	8	
JOINT, UNIVERSAL, 3/4" DR	1	D	5	9	
HANDLE, SLIDING-T, 3/4" DR, 17" LONG	1	D	5	10	
HANDLE, RATCHET, 3/4" DR, 17" LONG	1	D	5	11	
SOCKET, SOCKET WRENCH, 3/4" DR, 12 PT, 1-1/8"	1	D	5	12	
SOCKET, SOCKET WRENCH, 3/4" DR, 12 PT, 1-1/4"	1	D	5	13	
SOCKET, SOCKET WRENCH, 3/4" DR, 12 PT, 1-5/16"	1	D	5	14	
SOCKET, SOCKET WRENCH, 3/4" DR, 12 PT, 1-3/8"	1	D	5	15	
SOCKET, SOCKET WRENCH, 3/4" DR, 12 PT, 1-7/16"	1	D	5	16	
SOCKET, SOCKET WRENCH, 3/4" DR, 12 PT, 1-3/4"	1	D	5	17	
SOCKET, SOCKET WRENCH, 3/4" DR, 12 PT, 1-11/16"	1	D	5	18	
SOCKET, SOCKET WRENCH, 3/4" DR, 12 PT, 1-5/8"	1	D	5	19	
SOCKET, SOCKET WRENCH, 3/4" DR, 12 PT, 1-9/16"	1	D	5	20	
SOCKET, SOCKET WRENCH, 3/4" DR, 12 PT, 1-1/2"	1	D	5	21	
SOCKET, SOCKET WRENCH, 3/4" DR, 12 PT, 1-13/16"	1	D	5	22	
SOCKET, SOCKET WRENCH, 3/4" DR, 12 PT, 1-7/8"	1	D	5	23	
SOCKET, SOCKET WRENCH, 3/4" DR, 12 PT, 2"	1	D	5	24	
SOCKET, SOCKET WRENCH, 3/4" DR, 12 PT, 2-1/16"	1	D	5	25	
SOCKET, SOCKET WRENCH, 3/4" DR, 12 PT, 2-1/8"	1	D	5	26	
SOCKET, SOCKET WRENCH, 3/4" DR, 12 PT, 2-3/16"	1	D	5	27	
SOCKET, SOCKET WRENCH, 3/4" DR, 12 PT, 2-1/4"	1	D	5	28	
SOCKET, SOCKET WRENCH, 3/4" DR, 12 PT, 2-3/8"	1	D	5	29	

TM 9-4910-783-13&P

SATS FMM2 INVENTORY LIST

0060 00

NOMENCLATURE	QTY	RACK	DRAWER	LOCATION	INVENTORY AMOUNT
DRILL, ELECTRIC, PORTABLE, 3/8"	1	D	6	1	
BLADE, ABRASIVE CUT-OFF, 36 GRIT FLAP WHEEL	1	D	6	2	
BLADE, ABRASIVE CUT-OFF, 36 GRIT FLAP WHEEL	1	D	6	3	
BLADE, ABRASIVE CUT-OFF	1	D	6	4	
DRILL, ELECTRIC PORTABLE, 1/2"	1	D	6	5	
SANDER/GRINDER, 4-1/2"	1	D	6	6	
DRILL-DRIVER, ELECTRIC, 1/2"	1	D	6	7	
ACCESSORIES, DRILL AND SANDER	1	D	6	8-12	

D, 6

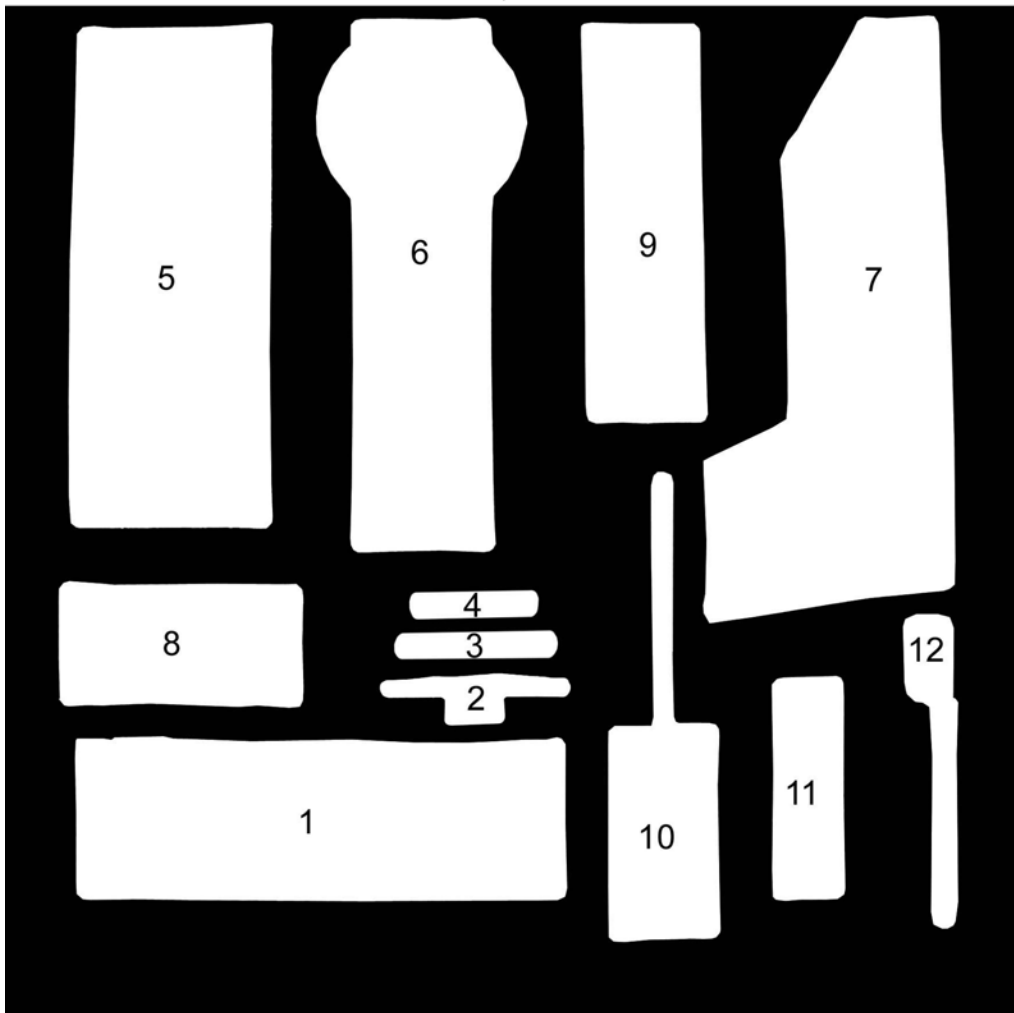

TM 9-4910-783-13&P

SATS FMM2 INVENTORY LIST

0060 00

NOMENCLATURE	INVENTORY				AMOUNT
	QTY	RACK	DRAWER	LOCATION	
OILER, HAND	1	D	7	1	
OILER, HAND	1	D	7	2	
ADAPTER KIT, GREASE GUN COUPLING	1	D	7	3	

D,7

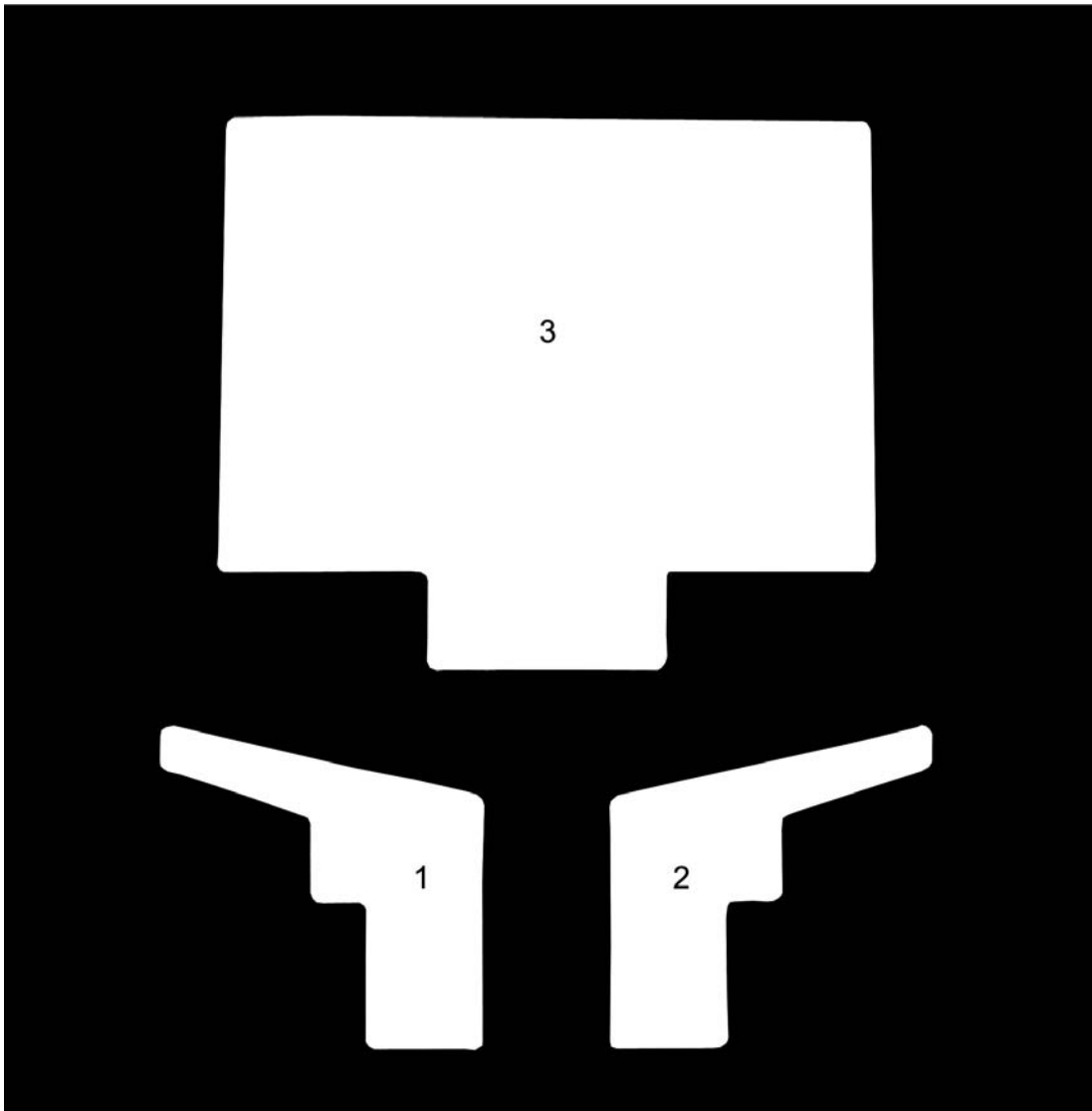

TM 9-4910-783-13&P

SATS FMM2 INVENTORY LIST

0060 00

INVENTORY

NOMENCLATURE	QTY	RACK	DRAWER	POSITION	AMOUNT
PULLER, PITTMAN ARM	1	E	8	1	
BEARING CUP PULLER ATTACHMENT	1	E	8	2	
BEARING SPLITTER, 4-5/8" MAX	1	E	8	3	
2-JAW PULLER, 13 TON, 11"	1	E	8	4	
BEARING SPLITTER, 15/16" MAX	1	E	8	5	
BEARING SPLITTER, 2" MAX	1	E	8	6	
2-JAW PULLER, 2 TON, 3-1/4"	1	E	8	7	
2-JAW PULLER, 7 TON, 5"	1	E	8	8	
2-JAW PULLER, 5 TON	1	E	8	9	

E, 8

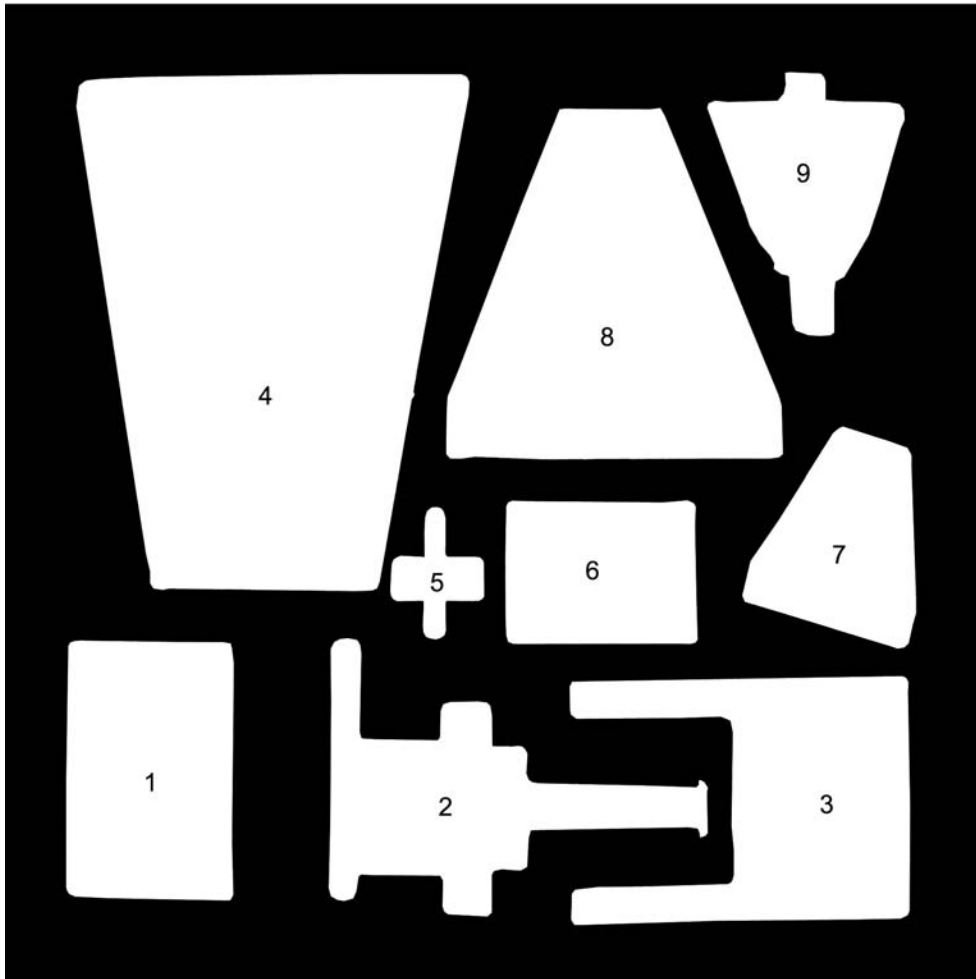

TM 9-4910-783-13&P

SATS FMM2 INVENTORY LIST

0060 00

THIS PAGE INTENTIONALLY LEFT BLANK

TM 9-4910-783-13&P

SATS FMM2 INVENTORY LIST

0060 00

E, 9

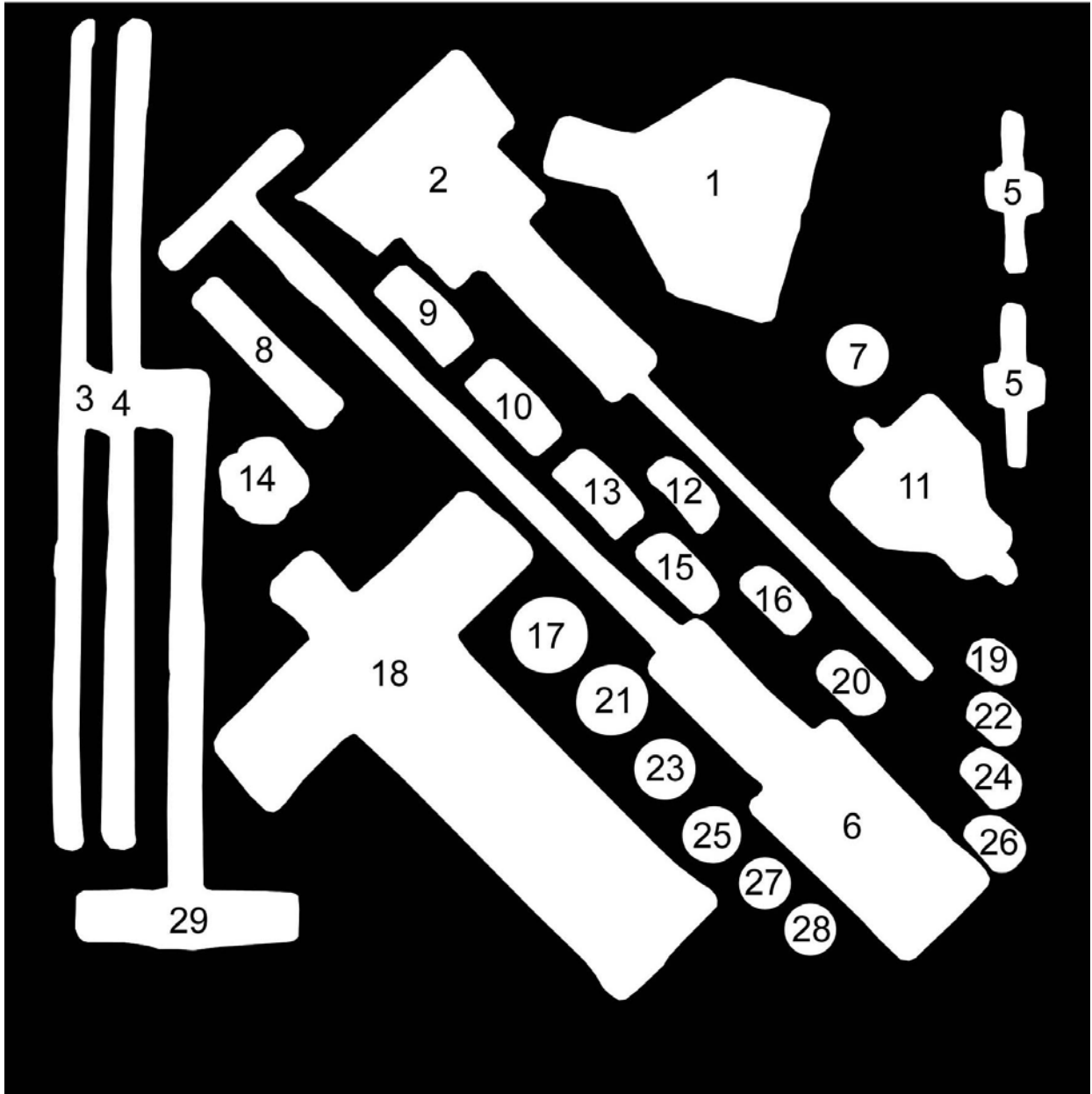

TM 9-4910-783-13&P

SATS FMM2 INVENTORY LIST

0060 00

NOMENCLATURE	INVENTORY				AMOUNT
	QTY	RACK	DRAWER	POSITION	
FLANGE-TYPE PULLER	1	E	9	1	
PILOT BEARING PULLER	1	E	9	2	
EXTENSION ROD	1	E	9	3	
EXTENSION ROD	1	E	9	4	
BOLTS - TWO LOCATIONS NUMBERED AS 5	1	E	9	5	
SLIDE HAMMER PULLER	1	E	9	6	
BOLTS FOR MECHANICAL PULLER SET	1	E	9	7	
BOLTS FOR SLIDE HAMMER PULLER	1	E	9	8	
STEP PLATE ADAPTER, 2-1/2"	1	E	9	9	
STEP PLATE ADAPTER, 2-3/8"	1	E	9	10	
STEERING WHEEL PULLER	1	E	9	11	
STEP PLATE ADAPTER, 1-7/8"	1	E	9	12	
STEP PLATE ADAPTER, 2-1/8"	1	E	9	13	
FEMALE THREADED ADAPTER, 1/2"	1	E	9	14	
STEP PLATE ADAPTER, 2"	1	E	9	15	
STEP PLATE ADAPTER, 1-3/4"	1	E	9	16	
FEMALE THREADED ADAPTER, 1-1/4"	1	E	9	17	
PUSH PULLER W/ 6-3/4" LEGS	1	E	9	18	
STEP PLATE ADAPTER, 1"	1	E	9	19	
STEP PLATE ADAPTER, 1-5/8"	1	E	9	20	
FEMALE THREADED ADAPTER, 1-1/8"	1	E	9	21	
STEP PLATE ADAPTER, 1-1/8"	1	E	9	22	
FEMALE THREADED ADAPTER, 1"	1	E	9	23	
STEP PLATE ADAPTER, 1-1/4"	1	E	9	24	
FEMALE THREADED ADAPTER, 7/8"	1	E	9	25	
STEP PLATE ADAPTER, 1-3/8"	1	E	9	26	
FEMALE THREADED ADAPTER, 3/4"	1	E	9	27	
FEMALE THREADED ADAPTER, 5/8"	1	E	9	28	
GEAR AND PULLEY PULLERS, 13"	1	E	9	29	
PULLER SET, MECHANICAL	1	E	9	1-29	

TM 9-4910-783-13&P

SATS FMM2 INVENTORY LIST

0060 00

INVENTORY

NOMENCLATURE	QTY	RACK	DRAWER	POSITION	AMOUNT
CABLE KIT, SPECIAL POWER	1	E	10	1	

E, 10

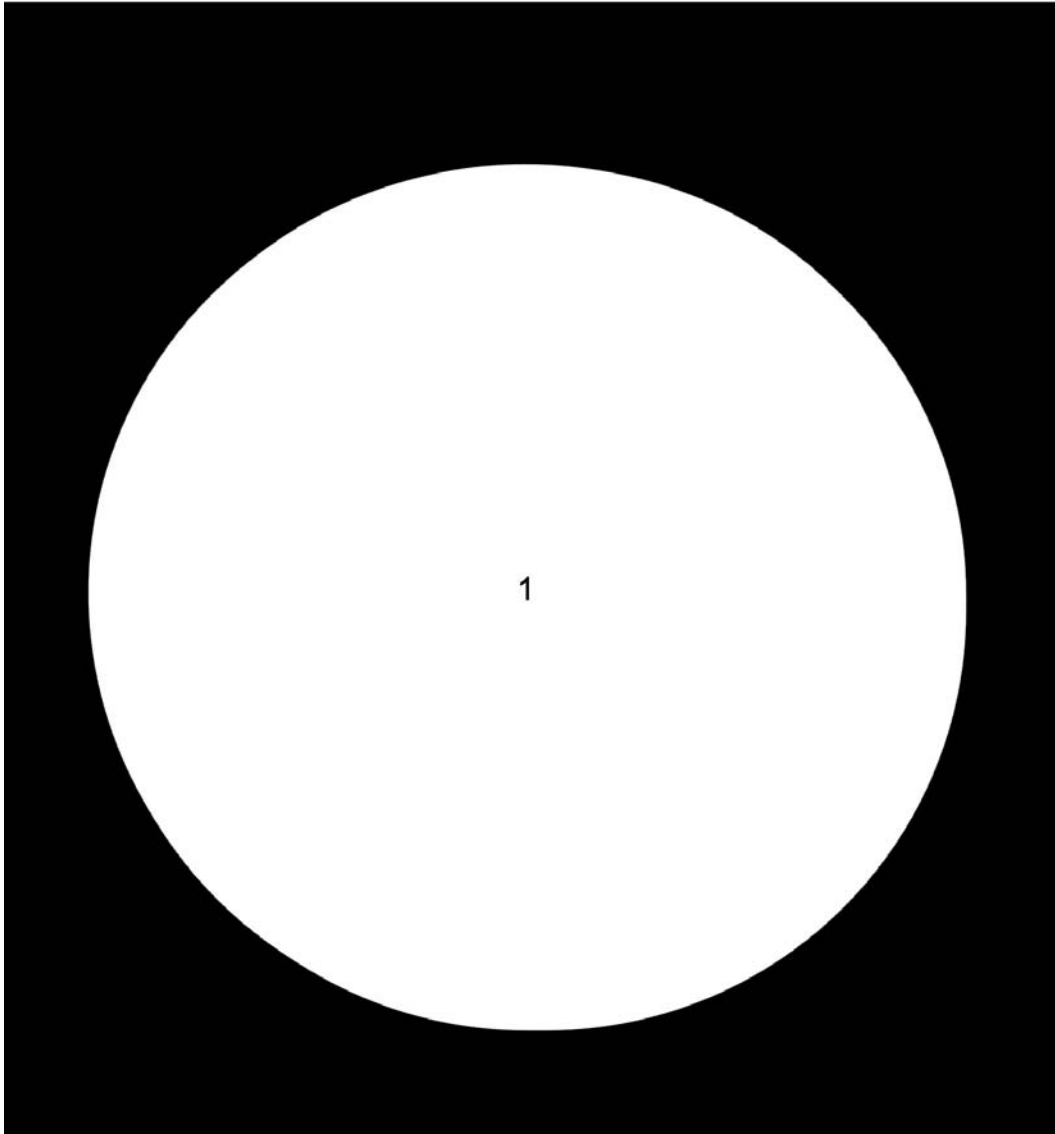

TM 9-4910-783-13&P

SATS FMM2 INVENTORY LIST

0060 00

INVENTORY

NOMENCLATURE	QTY	RACK	DRAWER	LOCATION	AMOUNT
BAR, PINCH, 60" (CROWBAR)	1	M		2	
PLATE, BOLSTER, 12 TON JACK, 24" X 24"	2	N		3	
PLATE, BOLSTER, 36" X 36"	1	N		4	
PLATE, BOLSTER, 1 TON JACK, TRANSMISSION, 48" X 72"	1	N		5	

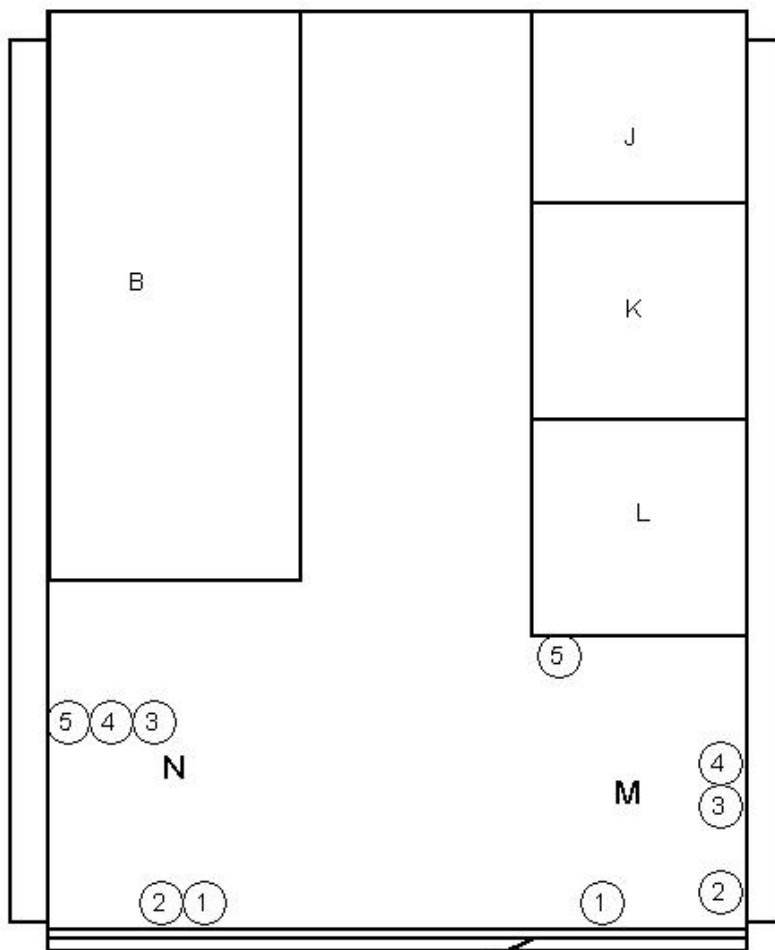

TM 9-4910-783-13&P

SATS FMM2 INVENTORY LIST

0060 00

INVENTORY

NOMENCLATURE	QTY	RACK	DRAWER	LOCATION	AMOUNT
MEASURE, LIQUID, 8 QUART	1	P		2	
MEASURE, LIQUID, 2 QUART	1	P		2	
BOX, TOTE	5	P		7	

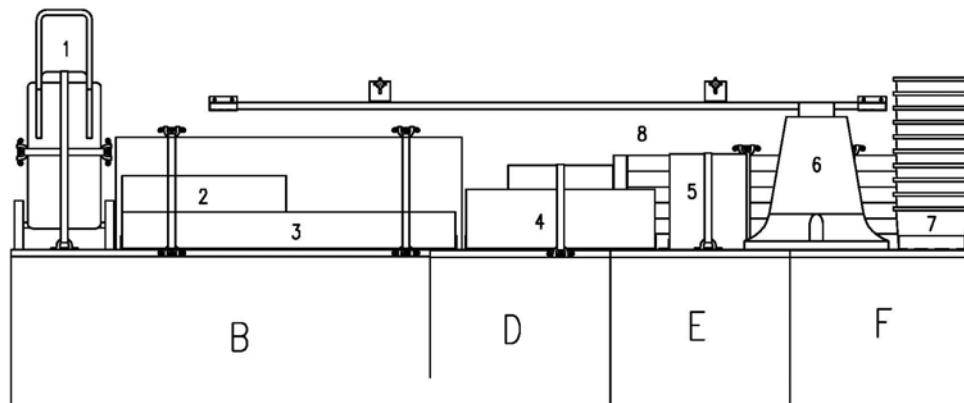
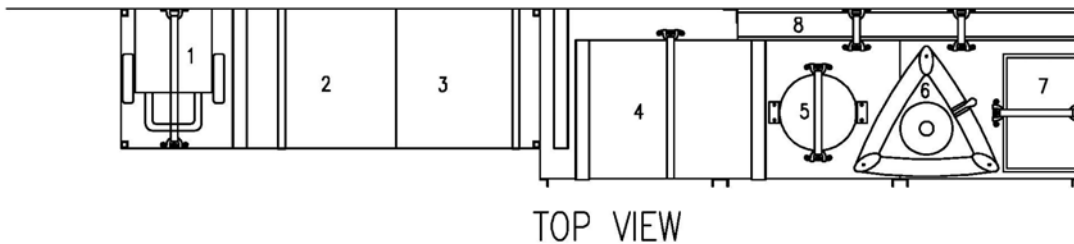

TM 9-4910-783-13&P

SATS FMM2 INVENTORY LIST

0060 00

INVENTORY

NOMENCLATURE	QTY	RACK	DRAWER	LOCATION	AMOUNT
HAMMER, SLEDGE, DOUBLE FACED, 10 LB	1	R		2	

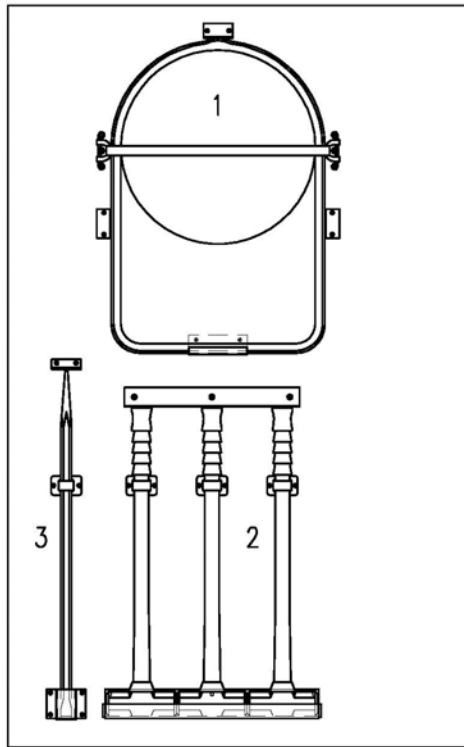

FRONT INTERIOR

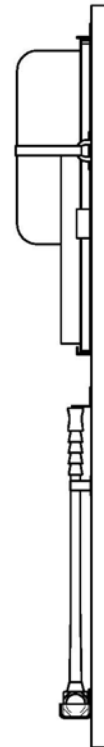

SIDE VIEW

VIEW OF R

TM 9-4910-783-13&P

GLOSSARY

Ballast - an electrical device for starting and regulating fluorescent and discharge lamps

Block T-Lock – Device used to secure ISO corners to one another.

Detent Rail – A piece of metal bolted along the lower left and right-hand side of container to allow for easier air transport.

Inclinometer - An instrument for showing the inclination of an object relative to the horizontal.

TM 9-4910-783-13&P

INDEX

Subject **WP Sequence No. – Page No.**

A

Area Light Assembly	
Installation	0013 00-2
Removal	0013 00-1
Assembly and Preparation for Use	0005 00-9

B

Base Tools	0058 00-1
Basic Issue Items	0056 00-7
Blackout Light Assembly	
Cleaning, Inspection	0031 00-2
Installation	0031 00-3
Removal	0031 00-1
Repair	0031 00-2

C

Caulking	0045 00-1
Ceiling Light	
Assembly	0032 00-4
Cleaning, Inspection	0032 00-3
Disassembly	0032 00-2
Installation	0032 00-4
Removal	0032 00-1
Repair	0032 00-4
Ceiling Light Ballast	
Installation	0014 00-3
Removal	0014 00-2
Ceiling Light Fixture	
Installation	0014 00-4
Removal	0014 00-3
Ceiling Light Fluorescent Tube	
Installation	0014 00-2
Removal	0014 00-2
Ceiling Light Lens	
Installation	0014 00-1
Removal	0014 00-1
Circuit Breaker	
Installation	0027 00-2
Removal	0027 00-1

TM 9-4910-783-13&P

INDEX

C

Circuit Breaker Panel	
Assembly	0027 00-4
Cleaning, Inspection	0027 00-3
Disassembly	0027 00-3
Installation	0027 00-4
Removal	0027 00-2
Repair	0027 00-3
Classification of Defects	0011 00-1
Communication Panel	
Installation	0029 00-2
Removal	0029 00-1
Components of End Item	0056 00-5
Computer Cabinet	
Installation	0025 00-2
Removal	0025 00-1
Container Inspection	0005 00-1
Container Lift Jack Assembly	
Installation	0044 00-2
Removal	0044 00-1
Corrosion Prevention Control (CPC)	0001 00-2

D

Decals (Stencils) and Instruction Plates	0005 00-20
Dents or Depressions, Repair	0040 00-1
Destruction of Army Material to Prevent Enemy Use	0001 00-3
Detent Rails	
Installation	0007 00-4
Removing from Container	0007 00-6
Removing from Storage	0007 00-3
Storing	0007 00-6
Door Gasket	
Installation	0038 00-1
Removal	0038 00-1

E

ECU	
Installation	0015 00-3
Removal	0015 00-1
Repair	0015 00-1
ECU Slide	
Installation	0022 00-2
Removal	0022 00-1
Emergency Power Shutdown	0006 00-2
Equipment Characteristics, Capabilities, and Features	0003 00-1
Equipment Data	0003 00-4
Expendable and Durable Items List	0057 00-2
External Connections	0005 00-10

TM 9-4910-783-13&P

INDEX

F

Field Maintenance Module 1	0059 00-1
Field Maintenance Module 2	0060 00-1
Flat Rack	
Loading	0047 00-5
Removing	0047 00-6
Fracture Repair	0042 00-1

G

Generator	
Installation	0016 00-3
Removal	0016 00-1
Repair	0016 00-1
Generator Access Panels	
Installation	0017 00-1
Removal	0017 00-1
Generator Slide	
Installation	0020 00-1
Removal	0020 00-1
Generator Slide Caster	
Installation	0019 00-2
Removal	0019 00-1
Generator Slide Frame	
Installation	0021 00-1
Removal	0021 00-1

H

I

Instructions for Requisitioning Parts from Commercial Sources	0055 00-1
Internal Receptacle Outlets	
Assembly	0033 00-3
Cleaning, Inspection	0033 00-2
Disassembly	0033 00-2
Installation	0033 00-3
Removal	0033 00-1
Repair	0033 00-3

J

K

TM 9-4910-783-13&P

INDEX

L

Leveling Container	0005 00-6
Limit Switch	
Adjustment	0035 00-3
Cleaning, Inspection.....	0035 00-2
Installation	0035 00-2
Removal	0035 00-1
Repair.....	0035 00-2
List of Abbreviations/Acronyms.....	0001 00-3
Load and Tie-Down Procedures	0005 00-14
Location and Description of Major Components	0003 00-1
Lubrication.....	0010 00-8

M

Main Door	
Installation	0039 00-2
Removal	0039 00-1
Main Generator Cable	
Installation	0026 00-2
Removal	0026 00-1
Maintenance Allocation Chart (MAC).....	0051 00-1
Maintenance Forms, Records, and Reports	0001 00-1
Moving Container in Transport Aircraft	0007 00-3
Moving Container with Crane/Hoist	0007 00-2
Moving Container with Forklift.....	0007 00-1

N

O

Operation Under Unusual Conditions	0006 00-1
Operation Under Usual Conditions	0005 00-1
Operator Controls and Indicators	0004 00-1

P

Paint Refinishing	0046 00-1
Panel Hasp	
Installation	0024 00-1
Removal	0024 00-1
Parts List Order Form.....	0054 00-1
Personnel Door Internal Handle and Locking Bar	
Installation	0023 00-2
Removal	0023 00-1
Personnel End Panel Mounted Controls and Indicators	0004 00-2
Power Input Receptacle	
Assembly.....	0028 00-3
Cleaning, Inspection.....	0028 00-3
Disassembly.....	0028 00-3
Installation	0028 00-4

TM 9-4910-783-13&P

INDEX

P

Power Input Receptacle	
Removal	0028 00-1
Repair	0028 00-3
Power Shutdown	0005 00-19
Preparation for Movement/Shipment	0047 00-1
Preparation for Storage	0047 00-6
Preventive Maintenance Checks and Services	0010 00-1
Punctures Repair	0041 00-1

Q

Quality of Material	0001 00-5
---------------------------	-----------

R

Ramps	
4'x4' Installation	0005 00-6
4'x14' Installation	0005 00-4
References	0049 00-1
Repair Parts and Special Tools List	0053 00-1
Reporting Equipment Improvement Recommendations	0001 00-1
Rivet	
Installation	0037 00-2
Removal	0037 00-1
Rivnut Repair	0043 00-1

S

Set Up	0005 00-4
Siting Requirements	0005 00-1

T

Theory of Operation	0002 00-1
Tool and Test Equipment	0052 00-1
Trailer	
Loading	0047 00-2
Removing from	0047 00-4
Troubleshooting	
Operator	0008 00-1
Unit	0009 00-1

U

Utility Step	
Installation	0030 00-1
Removal	0030 00-1

V

W

TM 9-4910-783-13&P

INDEX

Wall Switch	
Installation	0034 00-2
Removal	0034 00-1
Warranty	0001 00-3
Wire List	0048 00-1
Wiring	
Cleaning, Inspection.....	0036 00-2
Installation	0036 00-2
Removal	0036 00-1
Repair.....	0036 00-2

RECOMMENDED CHANGES TO PUBLICATIONS AND BLANK FORMS For use of this form, see AR 25-30; the proponent agency is OAASA	Use Part II (reverse) for Repair Parts and Special Tool Lists (RPSTL) and Supply Catalogs/ Supply Manuals (SC/SM)	DATE
---	---	------

TO: (Forward to proponent of publication or form) (Include ZIP Code)	FROM: (Activity and location) (Include ZIP Code) Your Name and Unit Address
---	--

PART I – ALL PUBLICATIONS (EXCEPT RPSTL AND SC/SM) AND BLANK FORMS

PUBLICATION/FORM NUMBER	DATE	TITLE
-------------------------	------	-------

ITEM	PAGE	PARA-	LINE	FIGURE NO.	TABLE	RECOMMENDED CHANGES AND REASON
SAMPLE						

<i>*Reference to line numbers with in the paragraph or sub paragraph.</i>		
TYPED NAME, GRADE, OR TITLE Your Name and Grade	TELEPHONE EXCHANGE/AUTOVON, PLUS EXTENSION Your Telephone Number	SIGNATURE Your Signature

TO: (Forward to proponent of publication or form) (Include ZIP Code)	FROM: (Activity and location) (Include ZIP Code)
---	---

PART II – ALL PUBLICATIONS (EXCEPT RPSTL AND SC/SM) AND BLANK FORMS

PUBLICATION/FORM NUMBER			DATE			TITLE		
PAGE NO.	COLM NO.	LINE NO.	NATIONAL STOCK NUMBER	REFERENCE NO.	FIGURE NO.	ITEM NO.	TOTAL NO. OF MAJOR ITEMS SUPPORTED	RECOMMENDED ACTIONS

PART III – REMARKS *(Any general remarks or recommendations, or suggestions for improvement of publications and blank forms. Additional blank sheets may be used if more space is needed.)*

**Reference to line numbers with in the paragraph or sub paragraph.*

TYPED NAME, GRADE, OR TITLE	TELEPHONE EXCHANGE/AUTOVON, PLUS EXTENSION	SIGNATURE
-----------------------------	--	-----------

By Order of the Secretary of the Army:

Official:



SANDRA R. RILEY

*Administrative Assistant to the
Secretary of the Army*

0522701

PETER J. SCHOOMAKER
*General, United States Army
Chief of Staff*

DISTRIBUTION: To be distributed in accordance with the Initial Distribution Number (IDN) 256852, requirements for TM 9-4910-783-13&P.

THE METRIC SYSTEM AND EQUIVALENTS

LINEAR MEASURE

1 Centimeter = 10 Millimeters = 0.01 Meter = 0.3937 Inch
 1 Decimeter = 10 Centimeters = 3.94 Inches
 1 Meter = 10 Decimeters = 100 Centimeters
 = 1000 Millimeters = 39.37 Inches
 1 Dekameter = 10 Meters = 32.8 Feet
 1 Hectometer = 10 Dekameters = 328.08 Feet
 1 Kilometer = 10 Hectometers = 1000 Meters
 = 0.621 Mile = 3,280.8 Feet
 Millimeters = Inches times 25.4
 Inches = Millimeters divided by 25.4

WEIGHTS

1 Centigram = 10 Milligrams = 0.154 Grain
 1 Decigram = 10 Centigrams = 1.543 Grains
 1 Gram = 0.001 Kilogram = 10 Decigrams
 = 1000 Milligrams = 0.035 Ounce
 1 Dekagram = 10 Grams = 0.353 Ounce
 1 Hectogram = 10 Dekagrams = 3.527 Ounces
 1 Kilogram = 10 Hectograms = 1000 Grams = 2.205 Pounds
 1 Quintal = 100 Kilograms = 220.46 Pounds
 1 Metric Ton = 10 Quintals = 1000 Kilograms = 1.1 Short Tons

LIQUID MEASURE

1 Milliliter = 0.001 Liter = 0.034 Fluid Ounce
 1 Centiliter = 10 Milliliters = 0.34 Fluid Ounce
 1 Deciliter = 10 Centiliters = 3.38 Fluid Ounces
 1 Liter = 10 Deciliters = 1000 Milliliters = 33.82 Fluid Ounces
 1 Dekaliter = 10 Liters = 2.64 Gallons
 1 Hectoliter = 10 Dekaliters = 26.42 Gallons
 1 Kiloliter = 10 Hectoliters = 264.18 Gallons

SQUARE MEASURE

1 Sq Centimeter = 100 Sq Millimeters = 0.155 Sq Inch
 1 Sq Decimeter = 100 Sq Centimeters = 15.5 Sq Inches
 1 Sq Meter (Centare) = 10 Sq Decimeters
 = 10,000 Sq Centimeters = 10.764 Sq Feet
 1 Sq Dekameter (Are) = 100 Sq Meters = 1,076.4 Sq Feet
 1 Sq Hectometer (Hectare) = 100 Sq Dekameters
 = 2.471 Acres
 1 Sq Kilometer = 100 Sq Hectometers
 = 1,000,000 Sq Meters = 0.386 Sq Mile

CUBIC MEASURE

1 Cu Centimeter = 1000 Cu Millimeters = 0.061 Cu Inches
 1 Cu Decimeter = 1000 Cu Centimeters = 61.02 Cu Inches
 1 Cu Meter = 1000 Cu Decimeters
 = 1,000,000 Cu Centimeters = 35.31 Cu Feet

TEMPERATURE

$5/9 (°F - 32°) = °C$
 $(9/5 \times °C) + 32° = °F$
 -35° Fahrenheit is equivalent to -37° Celsius
 0° Fahrenheit is equivalent to -18° Celsius
 32° Fahrenheit is equivalent to 0° Celsius
 90° Fahrenheit is equivalent to 32.2° Celsius
 100° Fahrenheit is equivalent to 38° Celsius
 212° Fahrenheit is equivalent to 100° Celsius

APPROXIMATE CONVERSION FACTORS

<u>TO CHANGE</u>	<u>TO</u>	<u>MULTIPLY BY</u>	<u>TO CHANGE</u>	<u>TO</u>	<u>MULTIPLY BY</u>
Inches.....	Centimeters.....	2.540	Centimeters.....	Inches.....	0.394
Feet.....	Meters.....	0.305	Meters.....	Feet.....	3.280
Yards.....	Meters.....	0.914	Meters.....	Yards.....	1.094
Miles.....	Kilometers.....	1.609	Kilometers.....	Miles.....	0.621
Square Inches.....	Square Centimeters.....	6.451	Square Centimeters.....	Square Inches.....	0.155
Square Feet.....	Square Meters.....	0.093	Square Meters.....	Square Feet.....	10.764
Square Yards.....	Square Meters.....	0.836	Square Meters.....	Square Yards.....	1.196
Square Miles.....	Square Kilometers.....	2.590	Square Kilometers.....	Square Miles.....	0.386
Acres.....	Square Hectometers.....	0.405	Square Hectometers.....	Acres.....	2.471
Cubic Feet.....	Cubic Meters.....	0.028	Cubic Meters.....	Cubic Feet.....	35.315
Cubic Yards.....	Cubic Meters.....	0.765	Cubic Meters.....	Cubic Yards.....	1.308
Fluid Ounces.....	Milliliters.....	29.573	Milliliters.....	Fluid Ounces.....	0.034
Pints.....	Liters.....	0.473	Liters.....	Pints.....	2.113
Quarts.....	Liters.....	0.946	Liters.....	Quarts.....	1.057
Gallons.....	Liters.....	3.785	Liters.....	Gallons.....	0.264
Ounces.....	Grams.....	28.349	Grams.....	Ounces.....	0.035
Pounds.....	Kilograms.....	0.454	Kilograms.....	Pounds.....	2.205
Short Tons.....	Metric Tons.....	0.907	Metric Tons.....	Short Tons.....	1.102
Pound-Feet.....	Newton-Meters.....	1.356	Newton-Meters.....	Pound-Feet.....	0.738
Pound-Inches.....	Newton-Meters.....	0.11375	Kilopascals.....	Pounds per Square Inch.....	0.145
Pounds per Square Inch.....	Kilopascals.....	6.895	Kilometers per Liter.....	Miles per Gallon.....	2.354
Ounce-Inches.....	Newton-Meters.....	0.007062	Kilometers per Hour.....	Miles per Hour.....	0.621
Miles per Gallon.....	Kilometers per Liter.....	0.425	°Fahrenheit.....	°Celsius.....	°C = (°F-32)x5/9
Miles per Hour.....	Kilometers per Hour.....	1.609	°Celsius.....	°Fahrenheit.....	°F = (9/5x°C)+32

PIN: 082664-000